

INVITATION FOR BIDS

LAVTA BUS SHELTER DEMOLITION AND MOVEMENT PROJECT #2017-17

Livermore Amador Valley Transit Authority
1362 Rutan Court, Suite 100
Livermore, CA 94551

Date of Issuance:	September 12, 2017
Pre-Bid Conference:	September 25, 2017 at 10:00 a.m.
Written Questions Due:	September 29, 2017 at 4:00 p.m.
Answers to Questions Provided:	October 3, 2017
Bids Due:	October 6, 2017 at 2:00 p.m.
Contract Award (estimated):	November 6, 2017
Notice to Proceed (estimated):	November 13, 2017
Project Completion:	Within Sixty Working Days of Notice to Proceed

Contact Info: Jennifer Yeamans
Senior Grants, Project Management & Contract Specialist
(925) 455-7555
jyeamans@lavta.org

TABLE OF CONTENTS

N-
NOTICE INVITING SEALED BIDS 1

GENERAL CONDITIONS & INSTRUCTIONS TO BIDDERS

GC-

1 DEFINITIONS OF TERMS 1
2 FORM OF BID AND SIGNATURE 1
3 BID FORM 2
4 OR APPROVED EQUAL CLAUSE 2
5 TAXES 2
6 CASH DISCOUNT 2
7 UNAUTHORIZED CONDITIONS 2
8 BIDDER'S SECURITY 2
9 SUBMISSION OF BID 3
10 WITHDRAWAL OF BID 3
11 BID OPENING 3
12 SOLE BID EVALUATION 3
13 BIDDER'S WAIVER 4
14 STATEMENT OF EXPERIENCE AND QUALIFICATIONS 4
15 PENALTY FOR COLLUSION 4
16 INTEREST OF AUTHORITY PERSONNEL 4
17 PROHIBITED INTEREST 4
18 AWARD OR REJECTION OF BIDS 4
19 BID PROTEST PROCEDURES 5
20 TIME FOR EXECUTION OF CONTRACT AND FILING BOND 5
21 DOCUMENTS DEEMED PART OF CONTRACT 5
22 MANNER OF EXECUTION OF CONTRACT 5
23 EFFECT OF EXTENSIONS OF TIME 6
24 LIQUIDATED DAMAGES 6
25 DELIVERY 6
26 MATERIAL AND WORKMANSHIP 6
27 INSPECTION/ACCEPTANCE 7
28 WARRANTY OF TITLE 7
29 WARRANTY 7
30 APPROVAL BY THE EXECUTIVE DIRECTOR 7
31 CONTRACTOR'S LIABILITY 7
32 CONTRACTOR'S INTELLECTUAL PROPERTY LIABILITY 8
33 CHANGES IN CONTRACT WORK REQUESTED BY THE AUTHORITY 8
34 CHANGES TO CONTRACT WORK REQUESTED BY THE CONTRACTOR 9
35 CLAIMS AND DISPUTES 9
36 EFFECT OF FAILURE TO COMPLETE CONTRACT 10
37 ASSIGNMENT AND DELEGATION 10
38 SUBCONTRACTING 10
39 TERMINATION OF CONTRACT 10
40 NON-EMPLOYEE PICKETING 11
41 ENVIRONMENTAL, SAFETY AND HEALTH STANDARDS COMPLIANCE 11
42 HAZARDOUS CHEMICALS AND WASTES 11
43 ANTITRUST CLAIMS 11
44 TITLE VI COMPLIANCE 12
45 EQUAL EMPLOYMENT OPPORTUNITY 12
46 ACCESS REQUIREMENTS FOR INDIVIDUALS WITH DISABILITIES 12

47	AUTHORITY'S WAIVER OF CONDITIONS	12
48	SEVERANCE	12
49	ATTORNEYS' FEES	12
50	GOVERNING LAW	13
51	RIGHTS AND REMEDIES OF THE AUTHORITY	13
52	PROHIBITION AGAINST CONTRACTING WITH DEBARRED SUBCONTRACTORS	13
53	SECURITIES IN LIEU OF RETENTION	13

SPECIAL PROVISIONS

		SP-
1	SCOPE OF CONTRACT	1
2	SCHEDULE OF ACTIVITIES	1
3	PRE-BID CONFERENCE	1
4	QUALIFICATION OF BIDDERS	1
5	PERMITS AND INSPECTIONS	2
6	QUESTIONS AND REQUESTS FOR CLARIFICATION	2
7	APPROVED EQUAL REQUESTS	3
8	APPROVED EQUAL PROCEDURES	3
9	BID FORMS	4
10	BID PRICES/COMPLETION OF BID FORM	4
11	PERFORMANCE OF WORK	4
12	BIDDER'S SECURITY	4
13	MARKING AND MAILING BIDS/BID OPENING	4
14	AWARD OF CONTRACT OR REJECTION OF BIDS	5
15	CONTRACT BONDS	5
16	INSURANCE	6
17	LABOR CODE REQUIREMENTS	10
18	SAFETY REQUIREMENTS	14
19	SUBMITTALS	14
20	TIME AND SCHEDULE FOR PERFORMANCE	15
21	DESIGNATION OF SUBCONTRACTORS	15
22	DISADVANTAGED BUSINESS ENTERPRISE PROGRAM	15
23	FINAL ACCEPTANCE	16
24	LIQUIDATED DAMAGES	16
25	PAYMENT AND INVOICING INSTRUCTIONS	16
26	TERMINATION OF CONTRACT	17
27	CLAIMS PROCEDURES	17
28	TECHNICAL ASSISTANCE	19
29	PROTECTION OF PROPERTY	19
30	DISQUALIFICATION QUESTIONNAIRE	19
31	AUTHORITY LOCATION	19
32	NON-COLLUSION AFFIDAVIT	19
33	ASSIGNMENT OF CLAIMS	19
34	THIRD-PARTY CLAIMS	20
35	UTILITY RELOCATION	20
36	EXCAVATION	20
37	TRENCH SAFETY	20
38	HAZARDOUS CHEMICALS AND WASTE	21
39	PROMPT PAYMENT TO SUBCONTRACTORS	21
40	FEDERAL TRANSIT ADMINISTRATION REQUIRED CONTRACT CLAUSES	21
41	UNFORSEEN CONDITIONS	33
42	ANTI-TRUST CLAIM ASSIGNMENT	34
43	BID PACKAGE	34

TECHNICAL SPECIFICATIONS

		TS-
1	GENERAL	1
2	CONFORMITY	1
3	RESPONSIBILITY	1
4	CLEAN UP	1
5	USE OF PREMISES	1
6	OTHER	1
7	THE WORK	2

BID FORMS

		B-
	BID FORMS	1
	GRAND TOTAL BID PRICE	1
	ACKNOWLEDGEMENT OF TERMS AND CONDITIONS	2
	BIDDER'S BOND	5
	SAMPLE IRREVOCABLE STANDBY LETTER OF CREDIT	7
	LIST OF REFERENCES	9
	NON-COLLUSION DECLARATION	11
	DISQUALIFICATION QUESTIONNAIRE	12
	REQUEST FOR APPROVED EQUALS FORM	13
	DISADVANTAGED BUSINESS ENTERPRISE (DBE) QUESTIONNAIRE	15
	DESIGNATION OF SUBCONTRACTORS AND SUB-BIDDERS	17
	LOBBYING CERTIFICATION	19
	DISCLOSURE OF LOBBYING ACTIVITIES	20
	BUY AMERICA CERTIFICATE	23

CONTRACT DOCUMENTS

		C-
	SAMPLE AGREEMENT	1
	SAMPLE PERFORMANCE BOND	5
	SAMPLE PAYMENTBOND	7
	SAMPLE INSURANCE CERTIFICATE	9

NOTICE IS HEREBY GIVEN THAT sealed Bids will be received by the Administrative Services Department of the Livermore Amador Valley Transit Authority (LAVTA) at its Administrative Offices, 1362 Rutan Court, Suite 100, Livermore, CA 94551, until **2:00 p.m. on October 6, 2017** to provide for the demolition and movement of bus shelters at four bus stops in Livermore, CA, in accordance with requirements of the Solicitation Documents, at which time they will be read.

A non-mandatory Pre-Bid Conference will be held at **10:00 a.m on September 25, 2017** at the **LAVTA Administrative Offices, located at 1362 Rutan Court, Suite 100, in Livermore, CA.** At this Conference, members of the LAVTA staff will be available to answer questions pertaining to the Contract Documents and Specifications. The Conference should take no longer than an hour.

All questions during the solicitation phase of this project shall be directed to Jennifer Yeaman, Authority's Project Manager, at the address above. You may also fax your written requests to 925-443-1375 or email jyeaman@lavta.org. All questions concerning this project, and all requests for Approved Equals, **must be received in writing no later than 4:00 p.m. on September 29, 2017.** The LAVTA written Response to Questions shall be posted on the LAVTA website (www.wheelsbus.com) **on October 3, 2017.**

Only signed Addenda issued by LAVTA are binding. Bidders are required to acknowledge receipt of all Addenda with their Bids.

Whether mailed or personally delivered, Bids must be addressed to Jennifer Yeaman, Authority's Project Manager, at Livermore Amador Valley Transit Authority, 1362 Rutan Court, Suite 100, Livermore, CA 94551, by the date and time set forth in the Solicitation Documents. **No late Bids will be accepted.**

Bids must be accompanied by a Bid Guaranty/Security in the form of a Certified or Cashier's Check, Bidder's Bond, or Irrevocable Standby Letter of Credit in the amount of at least ten percent of the total amount of the bid, as further defined in the Special Provisions. The Bid Guaranty/Security shall be retained by LAVTA and applied to any damages sustained by LAVTA in the event that the successful Bidder fails or refuses to enter into the Contract awarded to it.

Bidders bidding as the prime Contractor shall possess a valid California State Class A or Class B Contractor's License at the time of Contract award and throughout the Contract term. The Invitation for Bid is available at www.wheelsbus.com or may be requested in hard copy format at the Authority's offices.

This is a Public Works Contract. In accordance with section 1720 et seq. of the Labor Code, the general prevailing wage rates as established by the Director of the California Department of Industrial Relations will apply. The prevailing wage rates established by the State Director of Industrial Relations can be viewed at LAVTA's offices, are available on the State of California's website at <http://www.dir.ca.gov/> or can be obtained by mail addressed to: Prevailing Wage Unit, Division of Labor Statistics and Research, Department of Industrial Relations, P.O. Box 603, San Francisco, CA 94101.

No Contractor or subcontractor may be listed on a bid proposal or awarded a contract for a public works project unless registered with Department of Industrial Relations (DIR) pursuant to Labor Code section 1725.5 at the time of bid. For federally funded projects, the Contractor and subcontractors must be registered at the time of contract award. (See Labor Code section 1771.1(a).) Each bidder must submit proof of contractor registration with DIR (e.g. a hard copy of the relevant page of the DIR's database found at: <https://efiling.dir.ca.gov/PWCR/Search>). This Contract is subject to monitoring and enforcement by the DIR pursuant to Labor Code Section 1771.4.

Pursuant to Public Contract Code Section 22300, the successful Bidder may submit certain securities in lieu of the Owner retaining a portion of progress payments during the Project. Pursuant to California Civil Code Section 9950, the successful bidder shall furnish a payment bond if civil work exceeds twenty-five thousand dollars (\$25,000).

Bids will be examined and reported to the Board of Directors of LAVTA within 120 calendar days of the Bid opening. LAVTA reserves the right to reject any Bids or to waive any irregularity or informalities in any Bid or in

the bidding procedure. No Bidder may withdraw its Bid for a period of 120 calendar days after the date of opening of the Bids. Each Bidder will be notified in writing of LAVTA's intent to award a Contract.

LAVTA hereby notifies all Bidders that it is the policy of LAVTA to ensure nondiscrimination on the basis of race, color, sex, national origin, religion, age, disability, ancestry, medical condition, sexual orientation, or marital status in the award and administration of contracts that it awards. It is the intention of LAVTA to create a level playing field on which DBEs can compete fairly for contracts and subcontracts relating to LAVTA's construction, procurement, and professional service activities in accordance with LAVTA's DBE goals.

In connection with the performance of this Contract, full compliance with all applicable Safety and Health Standards and with all applicable laws and regulations concerning Equal Employment Opportunity will be required. The major provisions of LAVTA's policy are outlined in these Contract Specifications.

/s/ Tamara Edwards
Tamara Edwards
Procurement Officer

September 12, 2017
Date

The General Conditions and Instructions for Bidders (General Conditions) apply to all bidding except insofar as they may be modified by the Special Provisions, Federal Provisions, Davis-Bacon Act Wage Determinations, Technical Specifications, Bid Forms, or Addenda.

1. DEFINITION OF TERMS

Whenever in the bid or Solicitation Documents, the following terms or pronouns in place of them or abbreviations are used, the intent and meaning shall be interpreted as follows:

"Authority" or "LAVTA" means Livermore Amador Valley Transit Authority.

"Bid" means an offer submitted to the Authority in response to an Invitation for Bids (IFB) that is not subject to negotiation.

"Bid Documents" or "Solicitation Documents" or "Specifications" mean the Notice Inviting Bids, General Conditions and Instructions for Bidders, Special Provisions, Technical Specifications, Bid Forms, Bond Forms, Addenda, Exhibits, Drawings and Appendices, if any.

"Bid Form" means that part of the bid which contains the bid items, price, and other supporting information.

"Bidder" means the firm or individual submitting the bid.

"Board," "Directors," or "Board of Directors" means Livermore Amador Valley Transit Authority Board of Directors or members thereof.

"Contract" or "Agreement" is used interchangeably and means a binding understanding, enforceable by law, between two or more competent parties, obligating the seller to furnish the supplies or services and the buyer to pay for them.

"Contract Officer" means an employee or agent of the Authority responsible for the acquisition of supplies, materials, equipment, and services under the Contract.

"Contractor" means the successful Bidder to whom a Contract is awarded.

"Days" means calendar days unless otherwise indicated.

"Executive Director" means the Executive Director of the Livermore Amador Valley Transit Authority.

2. FORM OF BID AND SIGNATURE

The bid shall be made on the Bid Form(s) provided and shall be enclosed in a sealed envelope marked and addressed as required. If the Bidder is an individual, the bid shall be executed personally by the Bidder. If the Bidder is a co-partnership, it is desirable that the bid be executed by all of the partners, but it may be executed by one of them. If the Bidder is a corporation, it must be executed by two officers of the corporation consisting of (1) the chairman of the board, president or vice president; and (2) the secretary, assistant secretary, chief finance officer, assistant chief financial officer, treasurer, or assistant treasurer, or by a person authorized by the corporation to execute written bids on its behalf. If the Bid Form is executed by a person other than an officer, or by only one officer, there must be attached to the bid a certified copy of a resolution of the corporation authorizing such officer or person to execute written bids for and on behalf of the corporation. If the Bidder is a joint venture, the bid must be executed on behalf of each participating firm by officers or other individuals who have the full and proper authorization to do so. Bids submitted in any other form will be considered non-responsive and may be rejected.
No faxed or electronically-submitted bids or modifications will be considered.

3. BID FORM

Blank spaces on the Bid Form shall be properly filled in. The format and language of the Bid Form must not be changed and no additions shall be made to any of the items. Alteration by erasures or interlineations must be explained or noted on the Bid Form over the signature of the Bidder. If the unit price and the total amount named by the Bidder for any item do not agree, the unit price alone will be considered as representing the Bidder's intention. Any mathematical errors that appear on the face of the bid will be corrected by the Authority and the Authority will use the mathematically correct Grand Total Bid Price in determining the lowest monetary Bidder.

Unless otherwise stated in the Solicitation Documents, the Bidder shall include freight or delivery charges in the total price in its bid.

Submission of an alternative bid(s) except as specifically called for in the Solicitation Documents may render both bids non-responsive and may cause their rejection.

4. OR APPROVED EQUAL CLAUSE

In order to establish a basis of quality, certain materials, processes, or types of machinery and equipment may be specified in the Solicitation Documents by describing the process, by designating a manufacturer by name, brand, or product number, or by specifying a kind of material. It is not the intent of these Solicitation Documents to exclude other processes, equipment, or materials of equal value, utility, or merit which are approved by the Authority. Requests for approved equals are further detailed in the Special Provisions.

5. TAXES

The supplies, materials, or equipment called for in the Solicitation Documents will be used by the Authority in the performance of a governmental function and are exempt from taxation by the United States Government. The Authority will, if requested, furnish a tax exemption certificate and any and all affidavits and documents that may be necessary to establish such exemption. Unless otherwise specified in the Special Provisions or Bid Forms, unit prices shall not include state sales and use taxes. Contractors registered with the California Board of Equalization are required to facilitate payment of all sales and use taxes under the Contract. If a Contractor is not registered with the California Board of Equalization, the Authority will either require the Contractor to provide a receipt for all payments from the Authority separately itemizing the applicable sales or use taxes paid and forward all appropriate state taxes to the Board of Equalization, or assume responsibility for the payment of state sales and use taxes.

6. CASH DISCOUNT

The Bidder must state cash discount offered on Bid Form. The cash discount will not be considered in determining the lowest responsible and responsive Bidder. The Authority will not accept a cash discount with a term of less than ten days.

7. UNAUTHORIZED CONDITIONS

Unauthorized conditions, limitations, or provisions attached to a bid will render the bid non-responsive and may cause its rejection.

8. BIDDER'S SECURITY

Unless otherwise noted in the Special Provisions, each Bidder shall furnish and submit with its bid one of the following forms of Bidder's Security:

- a) Unconditional "certified check", "cashier's check", or "official check" drawn on a solvent bank payable to the order of Livermore Amador Valley Transit Authority;

- b) A Bidder's Bond using the form entitled "Bidder's Bond," provided with the Bid Forms, which is properly executed by the Bidder and an admitted surety insurer and is accompanied by the corporate surety's power of attorney. The surety's signature shall be notarized and the surety shall be acceptable to the Authority; or
- c) An Irrevocable Stand-by Letter of Credit, a sample of which is provided in the Bid Forms.

No personal or business checks will be accepted. The Bidder's Security shall be in the amount as specified in the Special Provisions.

Any condition or limitation placed upon the check or any alteration of the form of bond or Irrevocable Stand-by Letter of Credit, or imperfection in its execution will render it informal and may, at the option of the Authority, result in a rejection of the bid under which such check, bond, or Irrevocable Stand-by Letter of Credit is submitted. The Bidder's Security shall be a guarantee that the Bidder, if awarded the Contract, will execute the required Contract and bonds within 10 days after such Contract has been awarded to it or such additional time as may be allowed by the Authority. If the Bidder fails or refuses to execute the required Contract and bonds within that time, the money and proceeds from the Bidder's Security shall be applied towards payment of the resulting damage to the Authority of the delay and the necessity of accepting a higher or less desirable bid. The amount of the Bidder's Security shall not constitute a limitation upon the right of the Authority to recover for the full amount of such damage. The Bidder's Security shall remain in full force and effect until a written Contract is executed and all the required bonds are furnished.

The Bidder's Security of the successful Bidder and the next two lowest Bidders will be returned after execution of the Contract with the successful Bidder and the approval and acceptance on behalf of the Authority of all other Contract bonds and insurance requirements. The Bidder's Security of the other Bidders not one of the three lowest, will be returned promptly after the bids have been opened and reviewed by the Authority.

9. SUBMISSION OF BID

Prior to the time and date specified in the Notice Inviting Sealed Bids (Notice), Bidders shall deliver two counterparts of the bid (one original and one duplicate) to the Procurement Officer, at the address shown in the Notice. All bids shall be in a sealed envelope and properly marked with the Solicitation number and title and the Bidder's name. **Bids received after said time or date or at any other location than the place stated in the Notice will not be considered.**

10. WITHDRAWAL OF BID

A Bidder may withdraw its bid before the expiration of the bid due date and time without prejudice to itself, by submitting a written request for bid withdrawal to the Executive Director.

11. BID OPENING

At the due date and time specified in the Notice, the Executive Director or designee, will open, examine, and publicly read all bids received. Bidders, their representatives, and others interested, are invited to be present at the opening of bids. All bids will then be examined and reported to the Board usually within 90 to 120 days from receipt of bids. The Authority reserves the right to postpone the bid opening for any reason.

12. SOLE BID EVALUATION

In the event a single bid is received, the Authority may conduct a price and/or cost analysis of the bid to verify that the bid price is fair and reasonable. It should be recognized that a price analysis involves a comparison with other similar procurements and must be based on an established or competitive price for the products subject to the comparison. The comparison must be made with a purchase of similar volume and involving similar specifications. Where a difference exists, a detailed analysis must be made of the price differential and costs or reasons associated therewith.

Where it is impossible to obtain a valid price analysis, it may be necessary for the Authority to conduct a cost analysis of the bid price, which process entails examination and evaluation of the separate cost/profit elements of the bid quotation. The Bidder will be expected to cooperate in this process and to furnish the Authority with any and all requested documentation necessary to undertake the required analyses.

13. BIDDER'S WAIVER

The Bidder shall represent and warrant that it has sufficiently informed itself in all matters affecting the performance of the work or the furnishing of the labor, supplies, material, or equipment called for in the Specifications. The Bidder shall warrant that it has checked its bid for errors and omissions; that the prices stated in its bid are correct, and as intended by it, and are a complete and correct statement of its prices for performing the work or furnishing the labor, supplies, materials, or equipment required by the Solicitation Documents. The Bidder waives any claim for the return of its Bidder's Security if, on account of errors or omissions claimed to have been made by it in its bid, or for any other reason, it should refuse or fail to execute the Contract.

14. STATEMENT OF EXPERIENCE AND QUALIFICATIONS

The Bidder may be required, upon request of the Executive Director, to prove to the Authority's satisfaction that it has the necessary skill, experience, facilities, and ample financial resources to perform the Contract in a satisfactory manner and within the required time.

15. PENALTY FOR COLLUSION

If at any time it shall be found that the person, firm, or corporation to whom a Contract has been awarded has in presenting any bid or bids, colluded with any other party or parties, then the Contract so awarded shall be null and void and the Contractor and its sureties shall be liable to the Authority for all loss or damage which the Authority may suffer thereby; and the Board of Directors may re-award the Contract pursuant to appropriate procedures.

16. INTEREST OF AUTHORITY PERSONNEL

By submitting a bid, the Bidder represents and warrants that to the best of its knowledge, no director, officer or employee of the Bidder or Authority is in any manner interested directly or indirectly in the bid or in the Contract which may be made under it, or in any expected profits to arise therefrom, as set forth in Title 1, Division 4, Chapter 1, Article 4 (commencing with Section 1090) or Title 9 (commencing with Section 81000) of the Government Code of the State of California.

17. PROHIBITED INTEREST

No member, officer, or employee of the Authority, during his or her tenure or for one year after that tenure, shall have any interest, direct or indirect, in this Contract or the proceeds under this Contract, nor shall any such person act as an agent or attorney for, or otherwise represent, a Bidder or Contractor by making a formal or informal appearance, or any oral or written communication, before the Authority or any officer or employee of the Authority for a period of one year after leaving office or employment with the Authority if the appearance or communication is made for the purpose of influencing any action involving the issuance, amendment, award, or revocation of a Contract.

18. AWARD OR REJECTION OF BIDS

Award will be made or bids will be rejected by the Authority within the time specified in the Special Provisions or Bid Forms, or if not specified, within a reasonable time after bids have been opened. The Authority may reject any and all bids, and may reject a bid of any party who has been delinquent or unfaithful in any former Contract with the Authority. Also, the Authority reserves the

right to waive any irregularities or informalities in any bid or in the bidding procedure. If an award is made, it shall be made to the lowest responsive and responsible Bidder. All Bidders shall be notified of the award.

19. BID PROTEST PROCEDURES

The Authority maintains written procedures that must be followed for all bid protests. Copies of the complete bid protest procedures are available at the office of the Executive Director. **Failure to comply with any of the requirements set forth in the Authority's written bid protest procedures may result in rejection of the protest.**

Protests based upon restrictive specifications or alleged improprieties in the bidding procedure which are apparent or reasonably should have been discovered by the Bidder prior to the advertised bid due date, shall be filed in writing with the Executive Director, not later than five (5) calendar days prior to the bid due date. The protest must clearly specify in writing the grounds and evidence on which the protest is based. Staff shall respond to the protest with a written determination prior to the bid due date.

Protests based upon alleged improprieties that are not apparent or which could not have reasonably been discovered prior to the advertised bid due date or disputes over the staff recommendation for Contract award, shall be submitted in writing to the Executive Director, within five (5) days of postmark, faxed date, or other form of notification of the Authority's notice of Contract award recommendation. The protest must clearly specify in writing the grounds and evidence on which the protest is based. The Executive Director will respond to the protest, in writing, at least three (3) days prior to the meeting at which staff's recommendation to the Authority's Board of Directors will be considered.

Should the Bidder decide to appeal the response of the Executive Director and pursue its protest at the Board meeting, it will notify the Executive Director of its intention at least two (2) days prior to the scheduled meeting.

20. TIME FOR EXECUTION OF CONTRACT AND FILING BOND

The Bidder to whom award is made shall execute a written Contract with the Authority on the Authority's form of Contract and furnish the other bond(s) as required within 10 days of receiving the form of Contract and bond(s) for execution from the Authority.

If the Bidder to whom award is made fails to enter into the Contract as provided and furnish the required bond(s), the award may be annulled. An award may, at the discretion of the Board, be made to the Bidder whose bid is next most acceptable in the opinion of the Board and such Bidder shall fulfill every condition in the Solicitation Documents and form of Contract as if it were the party to whom the first award was made.

21. DOCUMENTS DEEMED PART OF CONTRACT

The Notice Inviting Sealed Bids, General Conditions and Instructions for Bidders, Special Provisions, Bid Forms, Technical Specifications, Appendices, Exhibits, Drawings and Addenda, if any, will be deemed parts of the Contract.

22. MANNER OF EXECUTION OF CONTRACT

If the Contractor is an individual, the Contract shall be executed personally by the Contractor. If the Contractor is a co-partnership, it is desirable that the Contract be executed by all of the partners, but it may be executed by one of them. If the Contractor is a corporation, it must be executed by two officers of the corporation consisting of (1) the chairman of the board, president, or vice president; and (2) the secretary, assistant secretary, chief finance officer, treasurer, or assistant treasurer, or by a person authorized by the corporation to execute written contracts on

its behalf. If the Contract is executed by a person other than an officer or by only one officer, there must be attached to the Contract a certified copy of a resolution of the corporation authorizing such officer or person to execute written contracts for and on behalf of the corporation. If the Contractor is a joint venture, the Contract must be executed on behalf of each participating firm by officers or other individuals who have the full and proper authorization to do so.

23. EFFECT OF EXTENSIONS OF TIME

Granting or acceptance of extensions of time to complete the work or furnish the labor, supplies, materials, or equipment required under the Contract will not release Contractor or the surety from Contractor's Performance Security.

24. LIQUIDATED DAMAGES

It is agreed by the parties to the Contract that TIME IS OF THE ESSENCE, and in the event of a delay in completion of the work or the delivery of the supplies, materials, or equipment beyond the date set forth in the Contract Documents, or authorized extensions, damage will be sustained by the Authority, and that it is or will be impracticable to determine the actual amount of the damage by reason of such delay. It is, therefore, agreed that the Authority shall be paid an amount as set forth in the Special Provisions as liquidated damages. If no amount is set forth, Contractor shall be liable for actual damages for each and every calendar day that performance of this Contract extends beyond the time herein specified, which sum or sums will be considered as liquidated damages in that the Authority will suffer by reason of delay or default.

25. DELIVERY

The Contractor shall prepare all equipment and materials for shipment in such a manner as to protect them from damage in transit, and shall be responsible for and repair all damaged parts or replace all losses incurred in the course of delivery of the equipment and materials to the Authority's facilities. When necessary, heavy parts shall be mounted on skids or crated, and all parts or materials that might otherwise be lost shall be boxed or wired in bundles. All parts shall be plainly marked for identification and destination.

26. MATERIAL AND WORKMANSHIP

All materials, parts, and equipment furnished by the Contractor shall be new, high grade and free from defects. Workmanship shall be in accordance with generally accepted industry standards. The Contractor shall establish and maintain quality assurance policies and procedures to insure compliance with these specifications. The Contractor shall extend full access to the Authority to its manufacturing facilities during normal working hours so that the Authority can inspect and monitor the Contractor's compliance with its established quality assurance procedures and the Authority's Specifications.

Any material or equipment not conforming to the requirement of these Solicitation Documents or found to be damaged or defective at the time of delivery shall be replaced by the Contractor without additional cost to the Authority.

If the Contractor shall fail to comply promptly with any order of the Executive Director to replace or repair damaged or defective material, equipment or work, the Executive Director, upon written notice to the Contractor, have the authority to deduct the cost of such replacement or repair from any compensation due or to become due to the Contractor.

Nothing in this section shall limit or restrict the provisions of the warranty of fitness as set forth in these General Conditions and Instructions for Bidders.

27. INSPECTION / ACCEPTANCE

Within 5 working days of delivery or work completion, the Authority shall inspect and test, to its own satisfaction, the material delivered or work completed to ensure Contract compliance. In the event that the material or work is in compliance with the Contract, the Authority shall accept the Services by processing the Contractor's invoice for payment in accordance with the procedures delineated in the Special Provisions.

If the Authority determines that there are any defects or deficiencies in the material or work, the Authority will send a rejection letter outlining any defects or deficiencies. The Contractor shall rectify these defects or deficiencies within five days of postmark, faxed date, or other form of notification, unless the Authority approves otherwise in writing. If the Contractor fails or refuses to rectify these defects or deficiencies to the Authority's satisfaction, the Authority may arrange to procure new material or correct the defective work at the Contractor's expense. The Authority may opt to deduct the amount for the new material or corrective work from any amounts due to the Contractor under this Contract.

28. WARRANTY OF TITLE

The Contractor shall warrant to the Authority, its successors and assigns, that the title to the material, supplies or equipment covered by the Contract, when delivered to the Authority or to its successor or assigns, is free from all liens and encumbrances.

29. WARRANTY

The Contractor guarantees and warrants that all work performed and items supplied under this Contract shall (1) conform to the Technical Specifications and all other requirements of this Contract; (2) fulfill its design functions and be fit for both its ordinary and intended purposes; (3) be free of all patent and latent defects in design, materials and workmanship; and (4) perform satisfactorily **for a minimum of one year following final acceptance.**

It is understood and agreed that by acceptance of this warranty and the acceptance of materials or supplies to be manufactured or assembled pursuant to these Specifications, the Authority does not waive any warranty, either expressed or implied in Sections 2312 to 2317, inclusive, of the Business and Professions Code of the State of California, or any products liability of the Contractor as determined by any applicable decisions of a court of the State of California or of the United States.

30. APPROVAL BY THE EXECUTIVE DIRECTOR

The Authority reserves the right to direct and supervise the work under this Contract through its Executive Director and his/her properly authorized agents on whose inspection all work shall be accepted or condemned. The Executive Director shall have full power to reasonably reject or condemn any materials furnished or work performed under the Contract which does not conform to the terms and conditions set forth in the Contract.

31. CONTRACTOR'S LIABILITY

The Contractor shall indemnify, keep and save harmless the Authority and its directors, officers, employees, and agents against all suits or claims that may be based on any injury to, or death of, any person or any damage to property that may occur, or that may be alleged to have occurred, arising from the performance of this Contract by the Contractor, whether or not it shall be claimed that the injury was caused through a negligent act or omission of the Contractor or its employees. The Contractor shall, at its own expense, pay all charges of attorneys and all costs and other expenses arising therefrom. If any judgment shall be rendered against the Authority in any such action, or if the Authority enters into a settlement to resolve the whole or a portion of such action, the Contractor shall at its own expense satisfy and discharge the same. Termination or expiration

of the Contract shall not affect the Contractor's duty to indemnify, keep and save harmless for suits or claims accruing during the Contract period.

32. CONTRACTOR'S INTELLECTUAL PROPERTY LIABILITY

The Contractor represents and warrants that its performance under this Contract, and all work, materials and equipment used in its performance of this Contract, will not infringe or misappropriate any intellectual property rights, such as patent, copyright, trademark or trade secret. In addition to the warranties and indemnities provided elsewhere in this Contract, the Contractor agrees that it will, at its own expense, indemnify, defend, and hold harmless the Authority and its directors, officers, employees, and agents against all demands, liabilities, damages, expenses, suits and proceedings that are based on any claim that the services, software, materials or equipment, or any part thereof, or any tool, article or process used in the manufacture thereof, or used in connection with the Contractor's work under this Contract, constitutes a violation, infringement, unauthorized use or misappropriation of any intellectual property of any third parties (including, without limitation, any trade secret, trademark, service mark, copyright, patent, process, method or device). If the institution or resolution of such a suit or proceeding requires the Authority to procure new non-infringing material or equipment, it may do so at the Contractor's expense.

The Authority will give the Contractor prompt notice in writing of the institution of the suit or proceeding. At no cost to the Authority and without diminishing the Contractor's duty to defend, the Authority shall have the right to control, monitor through counsel of its choosing, and participate in the defense (including, without limitation, selection of counsel) of any such demand, suit, or proceeding concerning matters relating to the Authority, none of which may be settled without the Authority's consent, which shall not be unreasonably withheld. The Authority, in its sole discretion, may permit the Contractor, through Contractor's counsel, to defend the same, and will give the Contractor all needed information, assistance, and authority to enable the Contractor to do so. If any third party files a claim or lawsuit against the Authority that impacts the Authority's ownership or use of work performed or materials or equipment supplied under this Contract, or any material components of this Contract, the Authority in its sole discretion may terminate this Contract for Contractor default. This indemnification shall survive the termination or expiration of this Contract.

33. CHANGES IN CONTRACT WORK REQUESTED BY THE AUTHORITY

If the Contractor, on account of conditions developing during performance of the Contract, finds it impracticable to comply with the Contract Specifications and applies in writing for a modification of requirements, such change may only be authorized by the Authority in writing.

The Authority may make additions or deletions at any time, by written supplement to the Agreement, within the Scope of Work and Services described in these Solicitation Documents. It is understood, however, that the amount of work, materials, or equipment required by the Contract may not be so increased or diminished as to substantially alter the general character or extent of the Contract.

The Executive Director, or his/her designee, will further authorize the Contractor to perform such additional work and furnish such additional materials or equipment at the Contractor's catalog prices, less discounts ordinarily allowed to users of such materials or equipment or at regular labor charges, less customary discount, or both. In the event that there are no such catalog prices or regular labor charges applicable to the change in the Contract work, the prices or charges shall be established by mutual agreement between the Authority and the Contractor.

If additional work, materials or equipment not mentioned, specified, indicated or otherwise provided for in the Solicitation Documents are requested by the Authority, the Contractor shall, if ordered by the Executive Director, or designee, undertake the performance of such additional work or the furnishing of such additional materials or equipment. The amount to be paid to the

Contractor shall be increased in an amount which the Executive Director, or designee, and the Contractor shall determine and mutually agree to be the reasonable value of such additional work, materials or equipment, and such determination and agreement shall be final and conclusive upon the Contractor.

In case any work, materials or equipment which are mentioned, specified, indicated or otherwise provided for in the Contract, or in the Specifications forming a part of the Contract, shall be required to be omitted from, in or about the work, the Contractor shall, if ordered by the Executive Director, or his/her designee, omit the performance of such work and the furnishing of such materials or equipment. There shall be deducted from the amount to be paid to the Contractor the amount which the Executive Director, and his/her designee, and the Contractor shall determine and mutually agree to be the reasonable value of such work, materials or equipment and such determination and agreement shall be final and conclusive upon the Contractor.

34. CHANGES TO CONTRACT WORK REQUESTED BY THE CONTRACTOR

If the Contractor encounters any unanticipated conditions or contingencies that may affect the Scope of Work or Services, or identifies any Authority conduct (including actions, inaction, and written or oral communications other than a formal Contract modification) that the Contractor regards as a change to the contract terms and conditions that may result in an adjustment in the amount of compensation specified herein, the Contractor shall so advise the Authority immediately upon notice of such condition, contingency or Authority conduct. The written notice shall explain the circumstances giving rise to the unforeseen condition or contingency and shall set forth the proposed adjustment in compensation.

In any event, such notification shall be made to the Executive Director, or designee, in writing and within not more than 10 calendar days from the date the Contractor encounters the unanticipated condition or contingencies, or identifies Authority conduct that would warrant a change to the Contract. This notice shall be given to the Authority prior to the time that Contractor performs any work or services or provides any item(s) related to the proposed adjustment in compensation. Failure to provide written notice and receive Authority approval for extra work, services, or item(s), prior to performing extra work, services or furnishing an item or items may, at the Authority's sole discretion, result in nonpayment of the invoices for the extra work, services, or item(s). The changes and negotiated equitable adjustment shall be expressed in a written modification to the Agreement, prior to implementation of such changes.

35. CLAIMS AND DISPUTES

The Contractor shall be solely responsible for providing timely written notice to the Authority of any claims for additional compensation and/or time in accordance with the provisions of the Contract. It is the Authority's intent to investigate and attempt to resolve any Contractor claims before the Contractor has performed any disputed work. In addition, the Authority desires to mitigate its responsibility (if any) for any Contractor claims before the disputed work is performed. Therefore, Contractor's failure to provide timely notice, as provided for in the Contract, shall constitute a waiver of Contractor's claims for additional compensation and/or time.

The Contractor shall not be entitled to the payment of any additional compensation for any cause, including any act, or failure to act, by the Authority, including the failure or refusal to issue a modification, or the happening of any event or occurrence, unless it has given the Authority due written notice of a potential claim. The potential claim shall set forth the reasons for which the Contractor believes additional compensation may be due, the nature of the costs involved, and the amount of the potential claim.

If based on an act or failure to act by the Authority, such notice shall be given to the Authority prior to the time that the Contractor has started performance of the work giving rise to the potential claim for additional compensation. In all other cases, notice shall be given within 10 days after the happening of the event or occurrence giving rise to the potential claim.

If there is a dispute over any potential claim, the Contractor shall continue to work during the dispute resolution process in a diligent and timely manner as directed by the Authority, and shall be governed by all applicable provisions of the Contract. The Contractor shall maintain cost records of all work which is the basis of any dispute.

If an agreement can be reached which resolves the Contractor's potential claim, the parties will execute a Contract modification to document the resolution of the potential claim. If the parties cannot reach an agreement with respect to the Contractor's potential claim, Contractor may file a claim pursuant to Special Provision 27 no later than 30 days after the Authority notifies the Contractor that an agreement cannot be reached regarding the potential claim.

36. EFFECT OF FAILURE TO COMPLETE CONTRACT

In case of failure on the part of the Contractor to complete this Contract within the specified time or within authorized extensions, the Authority may terminate the Contract and refuse to pay the Contractor or allow any further compensation for any labor, supplies, or materials furnished by it under the Contract. The Authority may proceed to complete such Contract either by reletting or otherwise, and the Contractor and its surety, when applicable, shall be liable to the Authority for any and all losses or damages which the Authority may suffer on account of the Contractor's failure to complete the Contract within such time.

37. ASSIGNMENT AND DELEGATION

The Contractor shall neither delegate any duties or obligations under this Contract nor assign, transfer, convey, sublet or otherwise dispose of the Contract or its right, title or interest in or to the same, or any part thereof, without previous consent in writing from the Executive Director.

38. SUBCONTRACTING

The Authority reserves the right to approve any subcontractor that is used under this Contract. The Contractor shall give its attention to, and be responsible for, the fulfillment of all terms of the Contract, and shall keep all Contract work under its control. Nothing in the Contract shall create any contractual relationship between the Authority and any subcontractor. The Contractor is fully responsible to the Authority for the acts and omissions of its subcontractors and persons either directly or indirectly employed by its subcontractors, just as it is for the acts and omissions of persons directly employed by the Contractor.

The Contractor shall not, without the prior written consent of the Executive Director, substitute any subcontractor in place of any previously-approved subcontractor. When a portion of the work which has been subcontracted by the Contractor is not being performed in a manner satisfactory to the Authority, the subcontractor shall be removed immediately upon the request of the Authority, and shall not be employed for any future work under the Contract.

39. TERMINATION OF CONTRACT

The Authority may terminate this Contract at any time by giving the Contractor 30 calendar days' written notice thereof. Notice of termination shall be sent by certified mail. Upon termination, the Authority shall pay the Contractor its allowable costs incurred to the date of termination and those costs deemed necessary by the Authority to effect termination.

In the event that the Contractor at any time during the entire term of this Contract breaches the requirements or conditions of the Contract, and does not within 10 calendar days of receipt of notice thereof from the Authority cure such breach or violation, the Authority may immediately terminate this Contract and shall pay the Contractor only its allowable costs to the date of termination. If the Contractor does cure the breach or violation, any subsequent breach or violation of any kind may be cause for immediate termination without notice.

40. NON-EMPLOYEE PICKETING

If an employee of the Contractor pickets the facilities of the Authority in connection with a labor dispute, the Authority may terminate or suspend the Contract immediately. In addition, the Contractor shall reimburse the Authority for expenses incurred by the Authority resulting from the picketing or Contract suspension or termination.

41. ENVIRONMENTAL, SAFETY AND HEALTH STANDARDS COMPLIANCE

The Contractor shall comply with applicable environmental statutes, regulations, and guidelines in performing the work under this Contract. The Contractor shall also comply with applicable Occupational Safety and Health Administration (OSHA) standards, regulations, and guidelines in performing the work under this Contract.

42. HAZARDOUS CHEMICALS AND WASTES

The Contractor shall bear full and exclusive responsibility for any release of hazardous or non-hazardous chemicals or substances during the course of its performance of this Contract. The Contractor shall immediately report any such release to the Authority's Project Manager, and Contractor shall be solely responsible for compliance with all applicable federal, State, and local laws and regulations regarding reporting of releases of hazardous chemical or substances to appropriate government agencies. The Contractor shall be solely responsible for all claims and expenses associated with the response to, removal and remediation of the release, including without limit, payment of any fines or penalties levied against the Authority by any agency as a result of such release and shall hold harmless, indemnify, and defend the Authority from any claims arising from such release. For purposes of this section only, the term "claims" shall include (1) all notices, orders, directives, administrative, or judicial proceedings, fines, penalties, fees, or charges imposed by any governmental agency with jurisdiction; and (2) any claim, cause of action, or administrative or judicial proceeding brought against the Authority, its directors, officers, employees or agents, or for any loss, cost (including reasonable attorneys' fees), damage or liability, sustained or suffered by any person or entity, including the Authority.

If in the performance of the work outlined in these Solicitation Documents the Contractor uses hazardous chemicals or substances or creates any hazardous wastes, as defined in federal and State law, all such resulting hazardous wastes shall be properly handled, stored and disposed of according to federal, State, and local laws, at the expense of the Contractor. The Contractor shall dispose of any and all such hazardous wastes under its own EPA Identification Number via a licensed hazardous waste transporter, at an appropriately permitted disposal facility selected by Contractor. In no event shall the Authority be identified as the generator of any such wastes. The Contractor shall determine whether any wastes generated during the performance of the work is hazardous waste, and shall notify the Project Manager if Contractor generates any hazardous wastes, and the Authority reserves the right to a copy of the results of any tests conducted on the wastes and, at Authority's cost, to perform additional tests or examine those wastes prior to disposition. The Contractor shall hold harmless, indemnify, and defend the Authority from any claims arising from the disposal of such hazardous wastes regardless of the absence of negligence or other malfeasance by Contractor.

43. ANTITRUST CLAIMS

The Contractor's attention is directed to California Government Code Section 4552, which shall be applicable to the Contractor and its subcontractors:

"In submitting a bid to a public purchasing body, the Bidder offers and agrees that if the bid is accepted, it will assign to the purchasing body all rights, title, and interest in and to all causes of action it may have under Section 4 of the Clayton Act (15 U.S.C. Section 12) or under the Cartwright Act (Chapter 2 (commencing with Section 16700) of Part 2 of Division 7 of the Business and Professions Code), arising from purchases of goods, materials, or services by the

Bidder for sale to the purchasing body pursuant to the bid. Such assignment shall be made and become effective at the time the purchasing body tenders final payment to the Bidder."

44. TITLE VI COMPLIANCE

During the performance of any Contract entered into pursuant to these Contract Documents, the Contractor, for itself, its assignees and successor in interest, agrees that it shall comply with Title VI of the Civil Rights Act of 1964 (42 U.S.C. Section 2000d) and the Regulations relative to nondiscrimination in federally assisted programs of the Department of Transportation, Title 49 CFR Part 21, as they may be amended from time to time, which are incorporated by reference and made a part of this Contract.

45. EQUAL EMPLOYMENT OPPORTUNITY

In connection with the performance of this Contract, the Contractor shall not discriminate against any employee or applicant for employment because of race, color, religion, citizenship, political activity or affiliation, national origin, ancestry, physical or mental disability, marital status, age, medical condition (as defined under California law), veteran status, sexual orientation, gender identity, gender expression, sex or gender (which includes pregnancy, childbirth, breastfeeding, or related medical conditions), taking or requesting statutorily protected leave, or any other characteristics protected under federal, state, or local laws. The Contractor shall take affirmative actions to ensure that applicants are employed, and that employees are treated during their employment, without regard to their race, religion, color, sex, disability, national origin, or any other characteristic protected under state, federal, or local laws. Such actions shall include, but not be limited to, the following: employment, upgrading, demotion or transfer, recruitment or recruitment advertising, layoff or termination, rates of pay or other forms of compensation; and selection for training, including apprenticeship. The Contractor further agrees to insert a similar provision in all subcontracts, except subcontracts for standard commercial supplies or raw materials.

46. ACCESS REQUIREMENTS FOR INDIVIDUALS WITH DISABILITIES

The Contractor agrees to comply with all applicable requirements of the Americans with Disabilities Act of 1990 (ADA), commencing at 42 U.S.C. Section 12101; Section 504 of the Rehabilitation Act of 1973, as amended, 29 U.S.C. Section 794; Section 16 of the Federal Transit Act, as amended; 49 U.S.C. Sections 5312 and 5332; and implementing regulations, as may be amended.

47. AUTHORITY'S WAIVER OF CONDITIONS

The waiver of any provision, term, or condition in these Solicitation Documents by the Authority on any particular occasion shall not constitute a general waiver of any other provision, term, or condition, nor a release from the Contractor's obligation to otherwise perform or observe any other provision, term, or condition of the Contract.

48. SEVERANCE

If any parts of the Solicitation Documents or Contract are declared invalid by a court of law, such decision will not affect the validity of any remaining portion, which shall remain in full force and effect.

49. ATTORNEYS' FEES

If any legal proceeding should be instituted by either of the parties to enforce the terms of this Contract or to determine the rights of the parties hereunder, the prevailing party in said proceeding shall recover, in addition to all court costs, reasonable attorneys' fees.

50. GOVERNING LAW

The Contract hereunder shall be governed by the laws of the State of California. The Contract must comply with all federal, State, and local laws, rules, and regulations applicable to the Contract and to the work to be done hereunder, including all rules and regulations of the Authority.

51. RIGHTS AND REMEDIES OF THE AUTHORITY

The rights and remedies of the Authority provided herein shall not be exclusive and are in addition to any other rights and remedies provided by law or under the Contract.

52. PROHIBITION AGAINST CONTRACTING WITH DEBARRED SUBCONTRACTORS

Contractor is prohibited from performing work on a public works project with a subcontractor who is ineligible to perform work on the public works project pursuant to Section 1777.1 or 1777.7 of the Labor Code.

53. SECURITIES IN LIEU OF RETENTION

Pursuant to Public Contract Code Section 22300, the successful Bidder may submit Securities in lieu of retention payments by the Authority. Upon Contractor's request, the Authority will make payment of funds withheld from progress payments, pursuant to the requirements of California Public Contract Code Section 22300, if Contractor deposits in escrow with the Authority or with a bank acceptable to the Authority, securities eligible for investment under California Government Code Section 16430, bank or savings and loan certificates of deposit, interest bearing demand deposit accounts, standby letters of credit, or any other security mutually agreed to by Contractor and the Authority, upon the following conditions:

(1) Contractor shall bear the expenses of the Authority and the escrow agent in connection with the escrow deposit made.

(2) Securities or certificates of deposit to be placed in escrow shall be of a value at least equivalent to the amounts of retention to be paid to Contractor pursuant to this article.

(3) Contractor shall enter into an escrow agreement satisfactory to the Authority, which agreement shall be substantially similar to the form provided in California Public Contract Code Section 22300.

(4) Contractor shall obtain the written consent of the surety to such agreement.

(This page intentionally left blank)

1. SCOPE OF CONTRACT

It is the intent of the Authority to award a Contract for the LAVTA Bus Shelter Demolition and Movement Project, in accordance with these specifications and as more particularly described in the Technical Specifications which are included herewith.

2. SCHEDULE OF ACTIVITIES

Listed below is the "Schedule of Activities" which outlines pertinent dates of which bidders should make themselves aware:

- A. Pre-Bid Conference -- **10:00 a.m. on September 25, 2017.** Please reference Special Provision 3.
- B. Requests for Clarification/Interpretation **must be in writing -- to be received by 4:00 p.m. on September 29, 2017.** Please reference Special Provision 6.
- C. Requests for Approved Equals -- **to be received by 4:00 p.m. on September 29, 2017.** Please reference Special Provisions 7 and 8.
- D. Authority's Response to Requests for Clarification/Interpretation and Requests for Approved Equals will be posted on the Authority's website at **www.wheelsbus.com on October 3, 2017.** Please reference Special Provision 6.
- E. Bid Opening – **2:00 p.m. on October 6, 2017.** Please reference Special Provision 13.

3. PRE-BID CONFERENCE

A Pre-Bid Conference will be held beginning at **10:00 a.m. on September 25, 2017,** at the LAVTA Administrative Offices, 1362 Rutan Court, Suite 100, Livermore, CA 94551. At this Conference, members of the Authority's staff will be available to answer questions pertaining to the Contract Documents and Specifications. The Conference should take approximately one hour. Attendance is not mandatory, but encouraged to ensure Bidders are familiar with the Scope of Work, equipment, procedures, and to allow an opportunity to visit the job site and take measurements. Bidders must ensure that when viewing the shelter sites that they are not parked illegally or causing any traffic hazard whatsoever.

4. QUALIFICATION OF BIDDERS

The Authority may reject the bid of any bidder deemed not to possess the minimum qualifications to perform the required work. In order to be deemed minimally qualified, a Bidder must, at the time of the bid opening:

- A. be a person or firm having the capabilities of performing the scope of work and securing specialty subcontractors who are properly licensed to perform the specialty work required for the types of services shown in the technical specifications; and
- B. have the equipment, materials, tools and labor force capable of performing the work within the required time frame; and
- C. be properly licensed in accordance with the laws of the State of California. **BIDDERS MUST POSSESS A VALID CLASS A or CLASS B Contractor's LICENSE** and shall maintain said license during the entire term of the Contract. Bidder must include on page B-3 of the bid its valid Class A or Class B license

number and expiration dates. All subcontractors performing on the contract shall be properly licensed by the State of California to perform specialized trades.

Each bidder shall submit the form entitled "List of References," Pages B-7 through B-8, which is a list of five (5) firms for which it provides or has provided comparable services within the past two years.

No Contractor or subcontractor may be listed on a bid proposal or awarded a contract for a public works project unless registered with Department of Industrial Relations (DIR) pursuant to Labor Code section 1725.5 at the time of bid. For federally funded projects, the Contractor and subcontractors must be registered at the time of contract award. (See Labor Code section 1771.1(a).)

FAILURE TO PROVIDE INFORMATION REGARDING EXPERIENCE MAY RESULT IN REJECTION OF THE BID.

5. PERMITS AND INSPECTIONS

All Municipal, County, State and Federal laws, rules and regulations governing or related to any portion of this requirement are hereby incorporated into and made a part of these specifications. All permits, licenses and inspections required by Municipal, County and State authorities shall be obtained, maintained in force and paid for by the Contractor. Any tests required by such authorities shall be conducted in the presence of such authorities or their authorized representatives.

The Authority reserves the right to inspect the bidder's premises prior to Contract award or at any time during the Contract period. Requests by the Contractor for inspection of the Authority's facility will require a 24 hour advance notice to the Facility Contract Administrator.

6. QUESTIONS AND REQUESTS FOR CLARIFICATION

If any person contemplating submitting a bid for the proposed Contract is in doubt as to the true meaning of any provision of these Contract Documents, they shall submit a written request to the named Contract Officer at the address set forth in Special Provision 13, for an interpretation or clarification no later than **4:00 PM, September 29, 2017**. Prospective bidders may also submit written requests to the named Contract Officer by email to: jyeamans@lavta.org. The Authority will respond to such requests on **October 3, 2017** by posting responses on the Authority's website at www.wheelsbus.com.

Any interpretation, change, or correction of these Contract Documents will be made by written Addendum that will be posted to the Authority's website. Upon such posting, such Addendum will become a part of the Contract Documents and binding on all bidders. The receipt of the Addendum by the bidder shall be acknowledged and so noted in the space provided for on the Bid Form. Oral explanations or instructions will not be binding on the Authority.

These Contract Specifications are intended to describe and provide for a completed work. In the event that there are inconsistencies or discrepancies between terms and conditions contained in the General Conditions, Special Provisions, and Technical Specifications, the terms and conditions contained in the Special Provisions and Technical Specifications shall govern over those included in the General Conditions.

7. APPROVED EQUAL REQUESTS

It is understood that specifying a brand name or specific types of components, equipment, and/or processes in these specifications shall not relieve the Bidder from its responsibility to furnish the end product in accordance with the warranty and contractual requirements. The Bidder is responsible for notifying the Authority of any inappropriate brand names, or types of components, equipment, and/or process that may be called for in these specifications, and to propose a suitable substitute for consideration. Unless otherwise specifically provided in the specifications, reference to any equipment, material, article, or patented process by trade name, make or catalog number shall be regarded as establishing a standard of quality and shall not be construed as limiting competition. A Bidder may, at its option, use any equipment, material, article, or process which, in the judgment of the Authority, is equal to that designated. To do so a Bidder shall furnish, at its own expense, all test results, technical data and background information required by the Authority in making the determination as to whether the proposed equipment, material or article or process, in the judgment of the Authority, is equal to that designated. This shall be submitted on Form B-11, Request for Approved Equals included in these Solicitation Documents.

The Authority shall be the sole judge as to the comparative quality and suitability of alternative equipment, articles, material, or process, and its decision shall be final.

8. APPROVED EQUAL PROCEDURES

- A. Prospective Bidders may discuss these specifications with the Authority's Contract Officer. This, however, will not relieve Bidders from the procedure of submitting written documented requests as required by Paragraph B below.
- B. Requests for Approved Equals must be received by the Authority, in writing, no later than **4:00 PM, September 29, 2017**. No such requests will be considered by the Authority if received after this date. Any request for an Approved Equal must be fully supported with technical data, test results, or other pertinent information as evidence that the substitute offered is equal to or better than the specification requirement. In addition, any test requirements in the specifications that pertain to an item under consideration for Approved Equal must be submitted with the request for Approved Equal. All requests for Approved Equals shall be addressed to the Contract Officer, Contracts and Procurement at the address set forth in Special Provision 13.

To be considered, all requests for approved equals must be in writing, separately identified and delineated for each Technical Specification, Special Provision, or other item, and must be submitted on Form B-11, Request for Approved Equals included in these Solicitation Documents.

A "denial" response from the Authority on a properly submitted written approved equals request or, in the absence of written requests for approved equals per the requirements and in the form set forth above, such submission or lack of submission thereof shall constitute a Bidder's acknowledgment and acceptance of all terms, conditions, specifications, and provisions contained in this solicitation.

- C. The Authority's reply to requests received pursuant to Paragraph B above will be posted on the Authority's Website at www.wheelsbus.com on **October 3, 2017**.

9. BID FORMS

Bids must be submitted on the bid forms provided. Bids submitted in any other form will be considered non-responsive and may be rejected. Any bid which is conditional in whole or in part, which revises or omits any requirement or provision of the Contract Documents and Specifications, which is based on any substitution for an item specified in the Contract Documents and Specifications when such substitution has not received formal approval by the Authority, or which includes an escalation clause or any other requirements or provisions not contained in the Contract Documents and Specifications may be considered non-responsive, and for that reason rejected.

10. BID PRICES/COMPLETION OF BID FORM

It is the intention of the Authority to award one Contract to the lowest responsive and responsible bidder for performing the work specified in the Contract Specifications. The determination of award will be made based on the lowest, responsive and responsible bid based upon a comparison of the Grand Total Bid Price as indicated on the Bid Form.

No Contractor or subcontractor may be listed on a bid proposal or awarded a contract for a public works project unless registered with Department of Industrial Relations (DIR) pursuant to Labor Code section 1725.5 at the time of bid. For federally funded projects, the Contractor and subcontractors must be registered at the time of contract award. (See Labor Code section 1771.1(a).)

This Contract is subject to monitoring and enforcement by the DIR pursuant to Labor Code Section 1771.4. The Contractor must post Site notices, as prescribed by Title 8 California Code of Regulations Section 16451(d). The Contractor and all subcontractors shall furnish the records specified in Labor Code Section 1776 directly to the Labor Commissioner, monthly in a format prescribed by the Labor Commissioner.

11. PERFORMANCE OF WORK

Contractor shall commence work only upon the Authority's issuance of a written Notice to Proceed, and shall continue until project acceptance, unless terminated sooner pursuant to Special Provision 26. Refer to Special Provision 20 for required time to complete the Project.

12. BIDDER'S SECURITY

Each bidder shall submit with its bid a Bidder's Security in the amount of at least ten percent (10%) of the total amount of the bid in a form satisfactory to the Authority, and as more particularly specified in Section 8 of the General Conditions and Instructions for Bidders.

13. MARKING AND MAILING BIDS/BID OPENING

Two counterparts – comprised of one original, and one duplicate of each bid, together with all of the required bid documents, shall be securely sealed in an envelope.

All bids must be received by the Authority's Contracts & Procurement Department by **2:00 PM on October 6, 2017**, at which time they will be opened and read.

The envelope shall be clearly marked with the bid number and shall also include the name and address of the bidder. The bid submittal shall be mailed or personally delivered to:

Livermore Amador Valley Transit Authority
1362 Rutan Court, Suite 100
Livermore, CA 94551
Attention: Procurement Officer

BIDS RECEIVED AFTER THE TIME AND DATE SPECIFIED WILL BE RETURNED UNOPENED.

14. AWARD OF CONTRACT OR REJECTION OF BIDS

With regard to Section 18 of the General Conditions and Instructions for Bidders, the award of Contract, if any, will be made within (120) calendar days after bid opening to the lowest responsive, responsible bidder. No bidder may withdraw its bid during said time period of (120) days.

Each bidder must submit a price quotation for the Grand Total Bid Price on the Bid Form. In determining the lowest responsive and responsible bidder, the Authority shall compare and evaluate the submitted bids in their entirety and make a determination on the basis of the bid submittals. Notification of award of Contract shall be made in writing to all bidders.

The Authority reserves the right to accept or reject any and all bids, or any items thereof; or to waive any informality or irregularity in the bids or in the bidding procedures.

15. CONTRACT BONDS

A. PERFORMANCE BOND

The bidder to whom the Contract is awarded shall furnish a **Performance Bond**, in an amount not less than 100 percent of the Grand Total Bid price, to guarantee performance of the contract.

The Performance Bond shall be on the forms bound herewith and shall be executed as surety by a corporation authorized to issue surety bonds in the State of California, with a financial condition and record of service satisfactory to Authority.

B. PAYMENT BOND

The bidder to whom the Contract is awarded shall furnish a **Payment Bond**, in an amount not less than 100 percent of the Grand Total Bid price, to secure payment of all persons supplying labor or materials for the construction of the work. Should the actual contract value exceed the Grand Total Bid Price during the contract term, the Payment Bond shall be increased in an amount not less than 100% of the increased value.

The Payment Bond shall be on the forms bound herewith and shall be executed as surety by a corporation authorized to issue surety bonds in the State of California, with a financial condition and record of service satisfactory to Authority.

All alterations, extensions of time, extra and additional work and other changes authorized by the Contract Documents may be made without securing the consent of the surety or sureties on the Payment Bond.

16. INSURANCE

The insurance requirements specified in this section shall apply to Contractor and any subcontractors, suppliers, temporary workers, independent contractors, leased employees, or any other persons, firms or corporations that Contractor authorizes to work under this Agreement (hereinafter collectively referred to as "Agents"). Contractor and all Agents are required to procure and maintain at their sole cost and expense the insurance coverages subject to all of the requirements set forth below. Such insurance shall remain in full force and effect throughout the term of this Agreement. To the extent that any Agent does not procure and maintain such insurance coverage, Contractor shall be responsible for said coverage and assume any and all costs and expenses that may be incurred in securing said coverage or in fulfilling Contractor's indemnity obligation as to itself or any of its Agents in the absence of coverage. In the event Contractor or its Agents procure excess or umbrella coverage to maintain certain requirements outlined below, these policies shall also satisfy all specified endorsements and stipulations, including provisions that the Contractor's insurance be primary without any right of contribution from the Authority. Prior to beginning work under this contract, Contractor shall provide the Authority with satisfactory evidence of compliance with the insurance requirements of this section.

A. Minimum Types and Scope of Insurance

1.) Workers' Compensation and Employers' Liability Insurance

- a. Workers' Compensation with Statutory Limits, as required by Section 3700 et seq of the California Labor Code, or any subsequent amendments or successor acts thereto governing the liability of employers to their employees.
- b. Employer's Liability coverage with minimum limits of \$1 million.
- c. Such insurance shall include the following endorsement as further detailed in the Endorsements Section below:
 - Waiver of Subrogation.

2.) Commercial General Liability Insurance

Commercial General Liability insurance for bodily injury and property damage coverage with a combined single limit for bodily injury and property damage of at least \$1 million per occurrence or claim and a general aggregate limit of at least \$2 million. Such insurance shall cover all of Contractor's operations both at and away from the project site.

- a. This insurance shall include coverage for, but not be limited to:
 - Premises and operations.
 - Products and completed operations.
 - Contractual liability.
 - Personal injury.
 - Advertising injury.
 - Explosion, collapse, and underground coverage (xcu).
 - Broad form property damage.
- b. Such insurance shall include the following endorsements as

further detailed in the Endorsements Section below:

- Additional Insured.
- Cross Liability or Severability of Interests Clause.
- Primary and Non-Contributory wording.
- Waiver of Subrogation.

Products and completed operations insurance shall be maintained for three (3) years following termination of this Agreement.

3.) Business Automobile Liability Insurance

Business Automobile Liability insurance providing bodily injury and property damage with a combined single limit of at least \$1 million per occurrence.

a. This insurance shall include coverage for, but not be limited to:

- All Owned vehicles.
- Non-owned vehicles.
- Hired or rental vehicles.

b. Such insurance shall include the following endorsements as further detailed in the Endorsements Section below:

- Additional Insured.
- Primary and Non-Contributory wording.
- Waiver of Subrogation.

4.) Property Insurance

Property insurance with Special Form coverage including theft, but excluding earthquake, with limits at least equal to the replacement cost of the property described below.

a. This insurance shall include coverage for, but not be limited to:

- Contractor's own business personal property and equipment to be used in performance of this Agreement.
- The Authority's interest in materials or property to be installed, if any.
- Debris removal.
- Builders risk for property in the course of construction.

b. Such insurance shall include the following endorsement as further detailed in the Endorsements Section below:

- Waiver of Subrogation.

B. ENDORSEMENTS

1) Additional Insured

The referenced policies and any Excess or Umbrella policies shall include as Additional Insureds the Livermore Amador Valley Transit

Authority and its directors, officers, employees, volunteers and agents while acting in such capacity, and their successors or assignees, as they now, or as they may hereafter be constituted, singly, jointly or severally.

2.) Waiver of Subrogation

The referenced policies and any Excess or Umbrella policies shall contain a waiver of subrogation in favor of the Livermore Amador Valley Transit Authority and its officers, directors, employees, volunteers and agents while acting in such capacity, and their successors and assignees, as they now, or as they may hereafter be constituted, singly, jointly or severally.

3.) Primary Insurance

The referenced policies and any Excess and Umbrella policies shall indicate that they are primary to any other insurance and the insurance company(ies) providing such policy(ies) shall be liable thereunder for the full amount of any loss or claim, up to and including the total limit of liability, without right of contribution from any of the insurance effected or which may be effected by the Livermore Amador Valley Transit Authority.

4.) Severability of Interests or Cross Liability

The referenced policies and any Excess or Umbrella policies shall contain either a Cross Liability endorsement or Severability of Interests Clause and stipulate that inclusion of the Livermore Amador Valley Transit Authority as an Additional Insured shall not in any way affect Authority's rights either as respects any claim, demand, suit or judgment made, brought or recovered against the Contractor. Said policy shall protect Contractor and the Livermore Amador Valley Transit Authority in the same manner as though a separate policy had been issued to each, but nothing in said policy shall operate to increase the insurance company's liability as set forth in its policy beyond the amount or amounts shown or to which the insurance company would have been liable if only one interest had been named as an insured.

C. EVIDENCE OF INSURANCE

All Coverages

Prior to commencing work or entering onto the Property, Contractor shall provide the Procurement Officer of the Authority with a certificate evidencing coverage, and upon request, a certified duplicate original of the policy. The certificate shall also show that the Contractors' policy(ies) will not be cancelled or coverage altered without 30 days prior written notice to the Authority's Executive Director.

D. GENERAL PROVISIONS

1.) Notice of Cancellation

The policies shall provide that the Contractors' policies will not be cancelled or have limits reduced or coverage altered without 30 days prior written notice to the Authority's Executive Director.

2.) Acceptable Insurers

All policies will be issued by insurers acceptable to the Authority (generally with a Best's Rating of A- 10 or better).

3.) Self-insurance

Upon evidence of financial capacity satisfactory to the Authority and Contractor's agreement to waive subrogation against the Authority respecting any and all claims that may arise, Contractor's obligation hereunder may be satisfied in whole or in part by adequately funded self-insurance.

4.) Failure to Maintain Insurance

All insurance specified above shall remain in force until all work to be performed is satisfactorily completed, all of Contractor's personnel and equipment have been removed from the Authority property, and the work has been formally accepted. The failure to procure or maintain required insurance and/or an adequately funded self-insurance program will constitute a material breach of this Agreement.

5.) Claims Made Coverage

If any insurance specified above shall be provided on a claim-made basis, then in addition to coverage requirements above, such policy shall provide that:

- a. Policy retroactive date coincides with or precedes the Contractor's start of work (including subsequent policies purchased as renewals or replacements).
- b. Contractor shall make every effort to maintain similar insurance for at least three (3) years following project completion, including the requirement of adding all named insureds.
- c. If insurance is terminated for any reason, Contractor agrees to purchase an extended reporting provision of at least three (3) years to report claims arising from work performed in connection with this Agreement.
- d. Policy allows for reporting of circumstances or incidents that might give rise to future claims.

6.) Deductibles and Retentions

Contractor shall be responsible for payment of any deductible or retention on Contractor's policies without right of contribution from the Authority.

E. PAYMENT OF WORKERS COMPENSATION

Each Contractor to whom a public works contract is awarded shall sign and file with the Authority the following certification, provided with the Bid Forms, prior to performing the work of the contract:

"I am aware of the provisions of Section 3700 of the Labor Code which requires every employer to be insured against liability for workers' compensation or to undertake self-insurance in accordance with the provisions of that code, and I will comply with such provisions before commencing the performance of the work of this Contract."

17. LABOR CODE REQUIREMENTS

The work performed under this Contract is subject to Public Works requirements. To the extent applicable, Contractors shall comply with California Labor Code and Prevailing Wage Laws. When both California and federal prevailing wage laws apply this Agreement, the Contractor and any Subcontractor(s) shall pay their workers the higher of the two prevailing wage rates. To the extent that contract provisions required by federal and state law are inconsistent, the Contractor is responsible for complying with the more comprehensive or stricter requirements. The Contractor and any Subcontractor(s) shall insert this clause in any lower tier contract. Federal prevailing wage rates, if applicable, are contained in the Supplemental General Provisions of the Contract Documents.

General Wage Determinations issued by the Director of Industrial Relations as applicable to the Livermore Amador Valley Transit Authority are available for inspection at the offices of the Authority.

Contractor and each subcontractor shall submit electronic certified payroll records to the California Labor Commissioner in the manner and format set forth in California Labor Code section 1771.4.

The Contractor's attention is directed to the following provisions of Labor Code Section 1776. The Contractor shall be responsible for the compliance with these provisions by its subcontractors:

- A. Hours of Labor. Eight hours labor constitutes a legal day's work. The Contractor or subcontractor shall, as a penalty to the state or political subdivision on whose behalf the Contract is made or awarded, forfeit \$25 for each worker employed in the performance of the Contract by the Contractor or subcontractor under him for each calendar day during which the worker is required or permitted to work more than 8 hours in any one calendar day and 40 hours in any one calendar week in violation of the provisions of the Labor Code Section 1813. Notwithstanding the provisions of Sections 1810 to 1814, inclusive, of the Labor Code and notwithstanding any stipulation inserted in any contract pursuant to the requirements of these sections, work performed by employees of the Contractor or subcontractor in excess of 8 hours per day and 40 hours during any one week shall be permitted upon compensation for all hours worked in excess of 8 hours per day and in excess of 40 hours during any one week at not less than 1½ times the basic rate of pay, as provided for in Section 1815. In addition, contractor/subcontractor may be required to pay double the basic rate of pay for all hours worked in excess of 12 hours in any workday and under other circumstances. (See California Code of Regulations sections 16100(c)(6), 16200(a)(3)(F) and applicable prevailing wage determinations.)
- B. Prevailing Wages. The Contractor and any subcontractor shall comply with Labor Code Sections 1774 and 1775. Pursuant to Section 1775, the Contractor and any subcontractor shall, as a penalty, forfeit to the state or political subdivision not

more than \$50 for each calendar day, or portion thereof, for each worker paid less than the prevailing rate as determined by the Director of Industrial Relations for the work or craft in which the worker is employed under the contract. The amount of this forfeiture shall be determined by the Labor Commissioner and shall be based on consideration of whether the failure to pay the correct rate of per diem wages was due to the Contractor's good-faith mistake, and on the previous record of the Contractor or subcontractor in meeting their respective prevailing wage obligations. In addition to said penalty, the difference between such prevailing wage rates and the amount paid to each worker for each calendar day or portion thereof for which each worker was paid less than the prevailing wage rate shall be paid to each worker by the Contractor or subcontractor.

If a worker employed by a subcontractor on a public works project is not paid at least the general prevailing per diem wages by the subcontractor, the Contractor shall not be liable for the penalties described above unless the Contractor had knowledge of that failure of the subcontractor to pay the specified prevailing rate of wages to those workers or unless the Contractor fails to comply with all of the following requirements:

The contract executed between the Contractor and the subcontractor for the performance of work on the public works project shall include a copy of the provisions of Sections 1771, 1775, 1776, 1777.5, 1813, and 1815 of the Labor Code.

The Contractor shall monitor the payment of the specified general prevailing rate of per diem wages by the subcontractor to the employees, by periodic review of the certified payroll records of the subcontractor.

Upon becoming aware of the subcontractor's failure to pay at least the specified prevailing rate of wages to the subcontractor's workers, the Contractor shall diligently take corrective action to halt or rectify the failure, including, but not limited to, retaining sufficient funds due the subcontractor for work performed on the public work project.

Prior to making final payment to the subcontractor for work performed on the public works project, the Contractor shall obtain an affidavit signed under penalty of perjury from the subcontractor that the subcontractor has paid at least the specified general prevailing rate of per diem wages to the subcontractor's employees on the public works project and any amount due pursuant to 1813 of the Labor Code.

Pursuant to Section 1775 of the Labor Code, the Division of Labor Standards Enforcement shall notify the Contractor on a public works project within 15 days of the receipt by the Division of Labor Standards Enforcement of a complaint of the failure of a subcontractor on that public works project to pay workers at least the general prevailing rate per diem wages.

Pursuant to the provisions of Section 1773 of the Labor Code, the Authority has obtained the general prevailing rate of wages applicable to categories of workers the Authority anticipates will be utilized for this project for straight time, overtime, Saturday, Sunday and holiday work. The holiday wage rate listed shall be applicable to all holidays recognized in the collective bargaining agreement of the particular craft, classification or type of workmen concerned, of if no collective bargaining agreement applies, those holidays identified in Government Code Section 6700. Prevailing wage rates for this project are available at the offices of the Authority. In the event that the Contractor intends to utilize categories of

workers different from, or in addition to, those anticipated by the Authority, it shall be Contractor's responsibility to bring such categories of workers to the Authority's attention immediately, and to obtain the appropriate wage rate from the Department of Industrial Relations (with the Authority's assistance if necessary). (See Title 8 California Code of Regulations Section 16202.)

The Contractor shall post general prevailing wage rates at a prominent place at the site of the work.

Pursuant to Labor Code Section 1773.6 and Title 8 California Code of Regulations Section 16204, changes in general prevailing wage determinations shall apply to the project only if issued by the Director of Industrial Relations prior to the Authority's bid issuance date.

The Authority will not recognize any claim for additional compensation because of the payment by the Contractor of any wage rate in excess of the prevailing wage rate set forth in the Contract. The possibility of wage increases is one of the elements to be considered by the Contractor in determining its bid, and will not under any circumstances be considered as the basis of a claim against the Authority on the Contract.

- C. Payroll Records. The Contractor's attention is directed to the following provisions of Labor Code Section 1776. The Contractor shall be responsible for compliance with these provisions by his subcontractors.
1. The Contractor and each subcontractor shall keep accurate payroll records, showing the name, address, social security number, work classification, straight time and overtime hours worked each day and week, and the actual per diem wages paid to each journeyman, apprentice, worker, or other employee employed by him or her in connection with the public work.
 2. The payroll records enumerated under subdivision (1) shall be certified and shall be available for inspection at all reasonable hours at the principal office of the Contractor on the following basis:
 - (a) A certified copy of an employee's payroll record shall be made available for inspection or furnished to such employee or his or her authorized representative on request.
 - (b) A certified copy of all payroll records enumerated in subdivision (1) shall be made available for inspection or furnished upon request to the Division of Labor Standards Enforcement and the Division of Apprenticeship Standards of the Department of Industrial Relations.
 - (c.) A certified copy of all payroll records enumerated in subdivision (1) shall be furnished to the Authority's Labor Compliance Officer at the time the Contractor invoices for authorized work.

A certified copy of all payroll records enumerated in subdivision (1) shall be made available upon request to the public for inspection or copies thereof made; provided, however, that a request by the public shall be made through either the Authority, the Division of Apprenticeship Standards or the Division of Labor

Standards Enforcement. If the requested payroll records have not been provided pursuant to paragraph (b), the requesting party shall, prior to being provided the records, reimburse the costs of preparation by the Contractor, subcontractor and the entity through which the request was made. The public shall not be given access to such records at the principal office of the Contractor.

3. Contractor and each subcontractor shall file a certified copy of the records enumerated in subdivision (1) with the entity that requests such records within 10 days after receipt of a written request.
 4. Any copy of records made available for inspection as copies and furnished upon request to the public or the Authority, the Division of Apprenticeship Standards or the Division of Labor Standards Enforcement shall be redacted in such a manner as to prevent disclosure of an individual's name, address and social security number. The name and address of the Contractor shall not be redacted.
 5. The Contractor shall inform the Authority of the location of records enumerated under subdivision (1), including the street address, city and county, and shall, within five working days, provide a notice of a change of location and address.
 6. The Contractor shall have 10 days in which to comply subsequent to receipt of written notice requesting the records enumerated in subdivision (1). Failure to comply after such 10-day period will subject Contractor to a penalty to the state or the political subdivision on whose behalf the contract is made or awarded, in the amount of \$25 for each calendar day, or portion thereof, for each worker, until strict compliance is effectuated. Upon the request of the Division of Apprenticeship Standards or the Division of Labor Standards Enforcement, such penalties shall be withheld from progress payments then due.
 7. The penalties specified in subdivision (6) above for noncompliance with the provisions of said Section 1776 may be withheld from any monies due or which may become due to the Contractor.
 8. The Contractor and each subcontractor shall preserve their payroll records for a period of 3 years from the date of completion of the Contract.
- D. Apprentices. The Contractor shall fully comply with the requirements of Sections 1777.5 and 1777.6 of the California Labor Code and the regulations of the California Apprenticeship Council. In accordance with Section 1777.5, the Contractor shall secure the necessary certificates and shall contribute to the apprenticeship fund or funds, as provided for therein. The Contractor shall require each subcontractor who will perform work or labor or render service to the Contractor in or about the construction of the work to comply fully with Sections 1777.5 and 1777.6 of the Labor Code. Information relative to apprenticeship standards, wage schedules and other requirements may be obtained from the State Division of Apprenticeship Standards and its branch offices.

For information regarding labor classifications and rate determinations, please visit the California Department of Industrial Relations website at <http://www.dir.ca.gov>. Bidders

may also contact the Authority's Procurement Officer with questions or submit their questions in writing pursuant to Special Provision 6.

18. SAFETY REQUIREMENTS

The Contractor shall promptly and fully comply with and carry out, and shall without separate charge to the Authority, enforce compliance with the safety and first aid requirements prescribed by applicable State and Federal laws and regulations, rules and orders, in an effort to ensure that work is done in a safe manner and that the safety and health of the employees and the people of local communities is safeguarded. Compliance with the provisions of this Section by subcontractors shall be the responsibility of the Contractor. All installed material, equipment and structures, without separate charge to the Authority, shall fully conform with all applicable State and Federal safety laws, rules, regulations and orders and it shall be the Contractor's responsibility to furnish only such material, equipment and structures, notwithstanding any omission in the Contract Documents related thereto or the indication of some other particular material, equipment or structure.

Upon the failure of the Contractor to comply with any of the requirements of this Section, the Project Manager shall have the authority, but not the duty, to stop any operations of the Contractor affected by such failure until such failure is remedied. No part of the time lost due to any such stop orders shall be made the subject of a claim for extension of time or for increased costs or damages by the Contractor.

The Contractor shall, at all times, exercise reasonable precautions for the safety of persons engaged in the performance of the work under this Contract ("Work") and those persons and property in the surrounding areas, utilizing signs and barriers as needed.

The Contractor shall provide such equipment and facilities as are necessary or required, in case of accident, for first aid service to any person who may be injured in the progress of the Work and shall have standing arrangements for the removal and hospital treatment of any employee who may be injured or who may become ill.

The Contractor shall keep records of all accidents in a bound book, including in such records such data as may be required by the laws and regulations of the State of California.

The Contractor must promptly report in writing to the Authority all accidents whatsoever, arising out of or in conjunction with the performance of the Work, whether on or adjacent to the site, which cause death, personal injury or property damages, giving full details and statements of witnesses. In addition, if death or serious injuries or serious damages are caused, the accident shall be reported immediately by telephone to the Authority.

If any claim is made by any third person against the Contractor or any subcontractor on account of any accident, the Contractor shall promptly report the fact in writing to the Authority, giving full details of the claim.

19. SUBMITTALS

Within 15 days of the issuance of the NTP, and prior to any fabrication or other performance, the Contractor will present to the Authority Facilities Contract Administrator, a work schedule and a summary of materials to be used in the performance of this project.

20. TIME AND SCHEDULE FOR PERFORMANCE

Working hours are outlined in the Technical Specifications. Liquidated Damages may be applied to any dates missed below. The work schedule will be as follows, with “days” meaning working days:

NTP	NTP issue date
NTP + 45 working days	Work to be substantially completed, inspected, punch list finalized
NTP + 60 working days	Work to be completed, inspected, and approved

21. DESIGNATION OF SUBCONTRACTORS

Contractor shall not subcontract any work to be performed by it under this Contract without the prior written approval of the Authority. Contractor shall be solely responsible for reimbursing any subcontractors and Authority shall have no obligation to them. Attention is directed to the requirements of Sections 4100 to 4113, inclusive, of the California Public Contract Code which are applicable to this Contract. Each Contractor shall list the name and business address of each subcontractor to whom the Contractor proposes to subcontract a portion of the work in an amount in excess of one-half of one percent (.5%) of the Total Contract Price, along with a description of the portion of the work which shall be done by each subcontractor, as part of the “Designation of Subcontractors and Sub-Bidders” form included in the Bid Forms. Contractor must list the license number and DIR registration number for each subcontractor, if applicable. Contractors are prohibited from performing work on a public works project with a subcontractor who is ineligible to perform work on the public works project pursuant to Section 1777.1 or 1777.7 of the Labor Code.

The Contractor shall pay any subcontractors approved by LAVTA for work that has been satisfactorily performed no later than ten (10) days from the date of successful completion of such work. In the event Contractor does not make such payments to the subcontractors in accordance with the time periods in this section, Contractor will be subject to a charge of two percent (2%) per month on the untimely or improperly withheld payment.

22. DISADVANTAGED BUSINESS ENTERPRISE PROGRAM

The Authority, a recipient of federal financial assistance from the Federal Transit Administration (FTA), is committed to and has adopted a Disadvantaged Business Enterprise Program for contracts in accordance with federal regulations 49 CFR Part 26, issued by the U. S. Department of Transportation (U.S. DOT).

It is the policy of the Authority to ensure nondiscrimination in the award and administration of all contracts and to create a level playing field on which Disadvantaged Business Enterprises (DBEs) can compete fairly for contracts and subcontracts relating to the Authority's construction, procurement and professional services activities. To this end, the Authority has developed procedures to remove barriers to DBE participation in the bidding and award process and to assist DBEs to develop and compete successfully outside of the DBE Program.

Pursuant to 49 CFR §26.13, and as a material term of any agreement with the Authority, the Contractor hereby makes the following assurance and agrees to include this assurance in any agreements it makes with Subcontractors in the performance of this contract:

The Contractor or Subcontractor shall not discriminate on the basis of race, color, national origin, or sex in the performance of this contract. The Contractor shall carry out applicable requirements of 49 CFR Part 26 in the award and administration of U.S. DOT-assisted contracts. Failure by the Contractor or Subcontractor to carry out these requirements is a material breach of this contract, which may result in the termination of this contract or such other remedy as the Authority deems appropriate.

The Contractor shall cooperate with the Authority in meeting its commitments and objectives with regards to insuring non-discrimination in the award and administration of Authority contracts and shall use its best efforts to insure that barriers to participation of Disadvantaged Business Enterprises (DBE) do not exist. To better help the Authority record and encourage DBE participation, all Bidders must complete, sign, and submit with their Bid the DBE/Subcontractor forms included in the Bid Forms.

By submitting a Bid, a Bidder is deemed to have made the foregoing assurance and to be bound by its terms.

23. FINAL ACCEPTANCE

The Contractor will schedule a preliminary inspection with the Authority Facilities Contract Administrator when work is substantially complete. This inspection will assess the work based on the contract specifications and related data as previously accepted by the Authority. Punch list items will be clearly noted with copies provided for both parties. Within 5 days of the completion of the punch list work the Contractor will schedule a final inspection with the Authority Facilities Contract Administrator.

24. LIQUIDATED DAMAGES

TIME IS OF THE ESSENCE IN THIS CONTRACT. In accordance with General Condition 24, and pursuant to Government Code Section 53069.85, the Contractor shall pay to the Authority the sum of two hundred dollars (\$200.00) per day for each and every calendar day that the Contractor fails to meet the schedule as specified in Special Provision 20.

The Contractor will be granted an extension of time and will not be assessed with liquidated damages for any delay beyond the time period specified in Special Provision 21 for delays caused by acts of God or of the public enemy, fire, floods, epidemics, quarantine, restrictions, strikes, labor disputes, shortage of materials and freight embargoes, or other causes deemed by the Authority to be beyond the reasonable control of the Contractor, provided Contractor notifies the Authority Facilities Contract Administrator in writing of the causes of delay within five (5) calendar days from the beginning of any such delay. The Authority Facilities Contract Administrator shall ascertain the nature of the delay and determine whether an extension of time is warranted, which determination shall be final and conclusive. Contractor has the burden of proof that the delay was beyond its control. The Contractor shall not be liable for any loss, damage, or delay as herein provided that is due to any cause beyond the Contractor's reasonable control.

25. PAYMENT AND INVOICING INSTRUCTIONS

The Authority will make a single lump sum payment to the Contractor, which shall include full compensation for furnishing all of the materials, labor, tools, equipment, warranty, bonding, and incidentals necessary to complete the work. No additional compensation will be allowed without the prior authorization from the Authority's Executive Director. The

Authority will inspect all work prior to payment. Payment will be made at the lump sum Grand Total Bid Price amount included on contractor's bid form.

After Final Acceptance of the work the Contractor shall thereupon furnish to the Authority satisfactory evidence that all liens, claims and demands of Subcontractors, laborers and materialmen, arising out of such work, are fully satisfied, and that all of the work is fully released from all liens, claims and demands of whatever kind and nature and whether just or otherwise. The Authority shall thereupon record a notice of completion and Contractor may invoice the Authority for final payment. The Authority shall make payment to the Contractor within 30 days of receipt of proper statements or invoices for the completed work. If the Authority fails to make payment in a timely manner, it shall pay interest to the Contractor at the legal rate set forth in Section 685.010 (a) of the California Code of Civil Procedure.

The acceptance by the Contractor of the final payment, whether such payment be made pursuant to any judgment of any court, or otherwise, shall constitute and operate as a release to the Authority of any and all claims of the Contractor and liability to the Contractor for anything theretofore done or furnished for or relating to or arising out of this Contract and the work done hereunder, and for any prior act, neglect or default on the part of the Authority or any of its directors, officers, agents or employees excepting only a claims against the Authority for the amounts deducted or retained in accordance with the terms and provisions of this Contract by law.

Should the Contractor refuse to accept the final payment as tendered by the Authority, it shall constitute waiver of any right to interest thereon.

The Authority is exempt from the payment of Federal Excise and Transportation Taxes, so such taxes must not be included in proposed prices. Sales tax should not be included in the proposed prices and will not be considered for the purpose of the bid evaluation.

26. TERMINATION OF CONTRACT

The Authority may terminate this Contract at any time by giving the Contractor thirty (30) calendar days' written notice. Notice of termination shall be by certified mail. Upon termination, the Authority shall pay the Contractor its allowable costs incurred to date of termination and those costs deemed necessary by Authority to effect termination. In the event that the Contractor at any time during the entire term of this Contract breaches the requirements or conditions of the Contract, and does not within ten (10) calendar days of receipt of notice from the Authority cure such breach or violation, the Authority may immediately terminate this Contract and shall pay the Contractor only its allowable costs to date of termination.

27. CLAIMS PROCEDURES

Compliance with all change order procedures is a prerequisite to filing a Public Contract Code Claim pursuant to this section. Claims must be submitted no later than (a) 30 days after change order negotiations and procedures are complete as per General Conditions 34, 35 and 36 or (b) 30 days after the occurrence of the event giving rise to the claim.

In accordance with the procedures set forth in Public Contract Code sections 9204 and 20104-20104.6, a Contractor may submit a claim by registered or certified mail with return receipt requested, for one or more of the following: (a) a time extension, including, without limitation, for relief from damages or penalties for delay assessed by the Authority; (b) payment by the Authority of money or damages arising from work done by, or on behalf of, the Contractor pursuant to this contract and payment for which is not otherwise

expressly provided or to which the Contractor is not otherwise entitled; or (c) payment of an amount that is disputed by the Authority.

The Contractor shall furnish reasonable documentation to support the claim, including but not limited to: 1) a clear, concise recital of the basis upon which the claim is asserted, including a designation of the provisions of the Contract Documents upon which the claim is based, 2) a statement as to the amount of time and/or compensation sought pursuant to the claim; 3) whether the Contractor's claim arises from an ongoing occurrence, and if so a description of the specific Work activities affected by the claim, 4) a time impact analysis in the event that Contractor requests a time extension, 5) full and complete cost records supporting the amount of any claim for additional compensation, and 6) a notarized certification by the Contractor as follows: "Under the penalty of law for perjury or falsification and with specific reference to the California False Claims Act, Government Code Section 12650 et seq., the undersigned hereby certifies that the information contained herein is a true, accurate and complete statement of all features relating to the claim asserted." Failure by the Contractor to provide sufficient documentation will result in denial of the claim. The Authority reserves the right to request additional documentation, or clarification of the documentation provided.

Upon receipt of a claim, the Authority will conduct a reasonable review and provide a written statement to the Contractor identifying what portion of the claim is disputed and what portion is undisputed within 45 days of receipt of the claim. The Authority and Contractor may, by mutual agreement, extend the 45 day time period. For any undisputed portion of a claim, the Authority must make payment within 60 days of its issuance of the written statement.

If the Contractor disputes the Authority's written statement, or if the Authority fails to respond, the Contractor may demand an informal conference to meet and confer for settlement of the issues in dispute. The Authority will then schedule the meet and confer conference within 30 days of the demand. Within 10 business days following the meet and confer conference, the Authority will provide a written statement identifying the portion of the claim that remain in dispute. Any payment due on an undisputed portion of the claim will be made within 60 days of the meet and confer conference.

After the meet and confer conference, any disputed portion of the claim shall be submitted to non-binding mediation. Alternatively, upon receipt of a claim, the parties may mutually agree to waive, in writing, mediation and proceed directly to the commencement of a civil action or binding arbitration, as applicable. If mediation is unsuccessful, the parts of the claim that remain in dispute shall be subject to applicable procedures set forth below.

Failure of a public entity to respond to a claim within the time periods described above shall result in the claim being deemed rejected in its entirety. Additionally, amounts not paid in a timely manner shall bear interest at 7 percent per year.

In the event that the mediation is unsuccessful, Contractor must file a government claim pursuant to Government Code section 910 et seq. in order to initiate a civil action.

In any civil action filed to resolve claims, the court shall submit the matter to nonbinding mediation within 60 days following the filing or responsive pleading, provided that the parties have not already participated in mediation of the claim as outlined above. If the matter remains in dispute after nonbinding mediation, the court shall submit the matter to judicial arbitration pursuant to Code of Civil Procedure section 1141.10 et seq. If the matter remains in dispute after judicial arbitration, the Authority or the Contractor may request a trial de novo.

28. TECHNICAL ASSISTANCE

The Contractor shall make available to the Authority, upon request, technical assistance for the purpose of assisting the Authority in resolving any problems that may arise in connections with the provision of any of the services called for under this Contract.

29. PROTECTION OF PROPERTY

The Contractor shall exercise every precaution to insure that no injury or damage occurs to Authority property or any existing structure as a result of its operations. Should any existing structure be damaged by or through any of the Contractor's operations, such injury or damage shall be replaced or repaired immediately by the Contractor, at Contractor's sole cost, in a manner satisfactory to the Authority.

30. DISQUALIFICATION QUESTIONNAIRE

Bidders shall complete and submit, under penalty of perjury, a standard form of questionnaire inquiring whether such prospective Bidder, any officer of such Bidder, or any employee of such Bidder who has a proprietary interest in such Bidder, has ever been disqualified, removed or otherwise prevented from Bidding on, or completing a federal, state or local government project because of a violation of law or safety regulation, and if so, to explain the circumstances.

A Bid may be rejected on the basis of a Bidder, any officer of such Bidder, or any employee of such Bidder who has a proprietary interest in such Bidder, having been disqualified, removed or otherwise prevented from Bidding on, or completing a federal, state, or local project because of a violation of law or a safety regulation.

All Bids shall be accompanied by an executed Disqualification Questionnaire as required by Public Contract Code Section 10162, on the form provided in the Bid Forms, see B-10.

31. AUTHORITY LOCATION

The facility where the work is to be performed is

LAVTA Bus Shelters
North Canyons Parkway at Independence Drive and Constitution Drive
Livermore, CA 94551

32. NON-COLLUSION DECLARATION

Pursuant to Public Contract Code section 7106, Contractor shall execute a Non-Collusion Declaration, in a form provided by the Authority, which is attached and incorporated herein.

33. ASSIGNMENT OF CLAIMS

In entering into a public works contract or a subcontract to supply goods, services, or materials pursuant to a public works contract, the Contractor or subcontractor offers and agrees to assign to the awarding body all rights, title, and interest in and to all causes of action it may have under Section 4 of the Clayton Act (15 U.S.C. Sec. 15) or under the Cartwright Act (Chapter 2 (commencing with Section 16700) of Part 2 of Division 7 of the Business and Professions Code), arising from purchases of goods, services, or materials pursuant to the public works contract or the subcontract. This assignment shall be made and become effective at the time the awarding body tenders final payment to the

Contractor, without further acknowledgement by the parties.

34. THIRD-PARTY CLAIMS

- A. Pursuant to Public Contracts Code Section 9201, the Authority shall have full authority to compromise or otherwise settle any claim relating to the Contract at any time.
- B. The Authority shall provide for timely notification to the Contractor of the receipt of any third-party claim relating to the contract. Notice shall be in writing and will be provided within thirty (30) days.
- C. The Authority shall be entitled to recover its reasonable costs incurred in providing the notification required by subdivision B.

35. UTILITY RELOCATION

Pursuant to California Government Code Section 4215, if during the course of the work the Contractor encounters utility installations which are not shown or indicated in the contract plans or in the specifications or which are found in a location substantially different from that shown, and such utilities are not reasonably apparent from visual examination of the work site, then it shall promptly notify LAVTA in writing. Where necessary for the work of the Contract, LAVTA will amend the contract to adjust the scope of work and the compensation to allow the Contractor to make such adjustment, rearrangement, repair, removal, alteration, or special handling of such utility, including repair of the damaged utility. If the Contractor fails to give the notice specified above and thereafter acts without instructions from LAVTA, then it shall be liable for any or all damage to such utilities or other work of the Contract which arises from its operations subsequent to the discovery, and it shall repair and make good such damage at its own cost.

36. EXCAVATION

In accordance with state law (Public Contract Code Section 7104), with respect to any work involving digging trenches or excavations that extend deeper than four feet, the Contractor shall notify LAVTA promptly in writing of any of the following conditions: (a) material that the Contractor believes may be hazardous waste, as defined in California Health and Safety Code Section 25117, that is required to be removed to a Class I, Class II or Class III disposal site in accordance with provisions of existing law; (b) subsurface or latent physical conditions at the site differing from those indicated; (c) unknown physical conditions at the site of any unusual nature, differing materially from those ordinarily encountered and generally recognized as inherent in work of the character provided for in the Contract Documents. Contractor shall notify LAVTA of such conditions prior to disturbing them, and shall await direction from LAVTA as to how to proceed.

37. TRENCH SAFETY

For all contracts over \$25,000, excavation for any trench 5 feet or more in depth shall not begin until the Contractor has received approval from LAVTA, of the Contractor's detailed plan for worker protection from the hazards of caving ground during the excavation of such trench. Such plan shall be submitted at least 5 days before the Contractor intends to begin excavation for the trench and shall show the details of the design of shoring, bracing, sloping or other provisions to be made for worker protection during such excavation. No such plan shall allow the use of shoring, sloping or a protective system less effective than that required by the Construction Safety Orders of the Division of Industrial Safety; and if such plan varies from the shoring system standards established

by the Construction Safety Orders, the plan shall be prepared and signed by an engineer who is registered as a Civil or Structural Engineer in the State of California. Attention is directed to the provisions of Section 6705 of the Labor Code concerning trench excavation safety plans.

38. HAZARDOUS CHEMICALS AND WASTE

The Contractor shall exercise every reasonable precaution to protect channels, storm drains, and bodies of water from pollution and shall conduct and schedule his operations so as to minimize or avoid muddying and silting of said channels, drains, and waters. Water pollution control work shall consist of constructing those facilities which may be required to provide prevention, control, and abatement of water pollution.

The Contractor shall bear full and exclusive responsibility for any release of hazardous or nonhazardous chemicals or substances during the course of the Work. The Contractor shall immediately report any such release to the Owner. The Contractor shall be solely responsible for all claims and expenses associated with the response to, removal and remediation of the release, including, without limit, payment of any fines or penalties levied against the Authority by any agency as a result of such release and shall hold harmless, indemnify and defend the Authority from any claims arising from such release. For purposes of this section only, the term "claims" shall include:

1. all notices, orders, directives, administrative or judicial proceedings, fines, penalties, fees or charges imposed by any governmental agency with jurisdiction, and
2. any claim, cause of action, or administrative or judicial proceeding brought against the Authority, its directors, employees, and agents for any loss, cost (including reasonable attorney's fees), damage or liability, sustained or suffered by any person or entity, including the Authority.

If the performance of the Work creates any hazardous wastes, those wastes shall be properly disposed of according to federal, state and local laws, at the expense of the Contractor. The Contractor shall dispose of the wastes under its own EPA Generator Number. In no event shall the Authority be identified as the generator. The Contractor shall notify the Authority of any such hazardous wastes, and the Authority reserves the right to a copy of the results of any tests conducted on the wastes and, at its cost, to perform additional tests or examine those wastes, prior to its disposition. The Contractor shall hold harmless, indemnify and defend the Authority from any claims arising from the disposal of the hazardous wastes, regardless of the absence of negligence or other malfeasance by Contractor.

39. PROMPT PAYMENT TO SUBCONTRACTORS

Because 100% of the Contract price will be paid to the Contractor within 30 days after acceptance of the work by the District, the District shall not hold retainage from or make progress payments to the Contractor. If the Contractor chooses to withhold retainage from subcontractors, the Contractor shall make prompt and full payment of any retainage within 30 days after each subcontractor's work is satisfactorily completed.

40. FEDERAL TRANSIT ADMINISTRATION REQUIRED CONTRACT CLAUSES

A. FLY AMERICA REQUIREMENTS.

The Contractor agrees to comply with 49 U.S.C. 40118 (the "Fly America Act") in accordance with the General Services Administration's regulations at 41 CFR Part 301 -

10, which provide that recipients and subrecipients of Federal funds and their consultants are required to use U.S. flag air carriers for U.S. Government-financed international air travel and transportation of their personal effects or property to the extent such service is available, unless travel by foreign air carrier is a matter of necessity as defined by the Fly America Act. The Contractor shall submit, if a foreign air carrier was used, an appropriate certification or memorandum adequately explaining why service by a U.S. flag air carrier was not available or why it was necessary to use a foreign air carrier and shall, in any event, provide a certificate of compliance with the Fly America requirements, if used. The Contractor agrees to include the requirements of this Section in all subcontracts that may involve international air transportation.

B. CARGO PREFERENCE REQUIREMENTS.

The Contractor agrees: (a) to use privately owned United States Flag commercial vessels to ship at least 50 percent of the gross tonnage (computed separately for dry bulk carriers, dry cargo liners, and tankers) involved, whenever shipping any equipment, material, or commodities pursuant to this Contract by ocean vessels to the extent such vessels are available at fair and reasonable rates for United States-flag commercial vessels; (b) to furnish within 20 working days following the date of loading for shipments originating within the United States or within 30 working days following the date of loading for shipments originating outside the United States, a legible copy of a rated, "on-board" commercial ocean bill-of-lading in English for each shipment of cargo described in the preceding paragraph to the Division of National Cargo, Office of Market Development, Maritime Administration, Washington, DC 20590 and to the Authority (through the Contractor in the case of a subcontractor's bill-of-lading); and (c) to include these requirements in all subcontracts issued pursuant to this Contract when the subcontract may involve the transport of equipment, Material, or commodities by ocean vessel.

C. BUY AMERICA REQUIREMENTS.

The Contractor agrees to comply with 49 U.S.C. 5323(j) and 49 CFR Part 661, which provide that Federal funds may not be obligated unless steel, iron, and manufactured products used in FTA-funded projects are produced in the United States, unless a waiver has been granted by FTA or the product is subject to a general waiver.

All proposers must submit the appropriate Buy America certification to the Authority with their bids, except those subject to a general waiver. Bids or offers that are not accompanied by a completed Buy America certification must be rejected as nonresponsive. This requirement does not apply to lower tier subcontractors.

D. ENERGY CONSERVATION.

The Contractor agrees to comply with mandatory standards and policies relating to energy efficiency which are contained in the state energy conservation plan issued in compliance with the Federal Energy Policy and Conservation Act, 42 U.S.C. §§ 6321 et seq.

E. RECYCLED PRODUCTS.

The Contractor agrees to provide a preference for those products and services that conserve natural resources, protect the environment, and are energy efficient by complying with and facilitating compliance with Section 6002 of the Resource Conservation and Recovery Act, as amended, 42 U.S.C. § 6962, and U.S. Environmental Protection Agency (U.S. EPA), "Comprehensive Procurement Guideline for Products Containing Recovered Materials," 40 C.F.R. part 247.

F. CLEAN WATER AND AIR REQUIREMENTS.

The Contractor agrees to comply with all applicable standards, orders or regulations issued pursuant to the Federal Water Pollution Control Act, as amended, 33 U.S.C. 1251 et seq., and the Clean Air Act, as amended, 42 U.S.C. 7401 et seq. The Contractor agrees to report each violation to the Authority and understands and agrees that the Authority will, in turn, report each violation as required to assure notification to the FTA and the appropriate EPA regional office.

The Contractor also agrees to include these requirements in each subcontract exceeding \$150,000 financed in part or in whole with federal assistance provided by the FTA.

G. LOBBYING.

Contractor shall file the certification required by 49 CFR Part 20, "New Restrictions on Lobbying." Contractor shall certify that it will not and has not used Federally appropriated funds to pay any person or organization for influencing or attempting to influence an officer or employee of any agency, a member of Congress, officer or employee of Congress, or an employee of a member of Congress in connection with obtaining any Federal contract, grant or any other award covered by 31 U.S.C. 1352. Contractor shall also disclose the name of any registrant under the Lobbying Disclosure Act of 1995 who has made lobbying contacts on its behalf with non-Federal funds with respect to that Federal contract, grant or award covered by 31 U.S.C. 1352. Such disclosures shall be forwarded to the Authority. Contractor shall ensure that all of its subcontractors/subconsultants under this Contract shall certify the same. The Authority is responsible for keeping the certification of the Contractor, who is in turn responsible for keeping the certification forms of subcontractors/subconsultants.

The Bidder shall complete Standard Form SF-LLL, "Disclosure of Lobbying Activities," which is included with the Bid Documents, including instructions for completion.

H. ACCESS TO RECORDS AND REPORTS.

Contractor shall provide all authorized representatives of the Authority, the FTA Administrator, the State Auditor and the Comptroller General of the United States access to any books, documents, papers and records of the Contractor which are directly pertinent to this Contract for the purposes of making audits, copies, examinations, excerpts and transcriptions. Contractor also agrees to maintain all books, records, accounts and reports required under this Contract for a period of not less than three years after the date of termination or expiration of this Contract, except in the event of litigation or settlement of claims arising from the performance of this Contract, in which case Contractor agrees to maintain the same until the Authority, the FTA Administrator, the Comptroller General, or any of their duly authorized representatives, have disposed of all such litigation, appeals, claims or exceptions related thereto.

I. FEDERAL CHANGES.

Contractor shall at all times comply with all applicable FTA regulations, policies, procedures and directives, including without limitation those listed directly or by reference in the Agreement (Form FTA MA (23) dated October 1, 2016) between the Authority and the FTA, as they may be amended or promulgated from time to time during the term of this Contract. Contractor's failure to so comply shall constitute a material breach of this Contract.

J. NO GOVERNMENT OBLIGATION TO THIRD PARTIES.

The Authority and Contractor acknowledge and agree that, notwithstanding any concurrence by the Federal Government in or approval of the solicitation or award of the underlying contract, absent the express written consent by the Federal Government, the Federal Government is not a party to this Contract and shall not be subject to any obligations or liabilities to the Authority, Contractor, or any other party (whether or not a party to that contract) pertaining to any matter resulting from the underlying contract.

The Contractor agrees to include the above clause in each subcontract financed in whole or in part with Federal assistance provided by FTA. It is further agreed that the clause shall not be modified, except to identify the subcontractor/subconsultant who will be subject to its provisions.

K. PROGRAM FRAUD AND FALSE OR FRAUDULENT STATEMENTS AND RELATED ACTS.

The Contractor acknowledges that the provisions of the Program Fraud Civil Remedies Act of 1986, as amended, 31 U.S.C. § 3801 et seq. and U.S. DOT regulations, "Program Fraud Civil Remedies," 49 CFR Part 31, apply to its actions pertaining to this Project. Upon execution of the underlying contract, the Contractor certifies or affirms the truthfulness and accuracy of any statement it has made, it makes, it may make, or causes to be made, pertaining to the underlying contract or the FTA assisted project for which this Contract work is being performed. In addition to other penalties that may be applicable, the Contractor further acknowledges that if it makes, or causes to be made, a false, fictitious, or fraudulent claim, statement, submission, or certification, the Federal Government reserves the right to impose the penalties of the Program Fraud Civil Remedies Act of 1986 on the Contractor to the extent the Federal Government deems appropriate.

The Contractor also acknowledges that if it makes, or causes to be made, a false, fictitious, or fraudulent claim, statement, submission, or certification to the Federal Government under a contract connected with a project that is financed in whole or in part with Federal assistance originally awarded by FTA under the authority of 49 U.S.C. § 5307, the Government reserves the right to impose the penalties of 18 U.S.C. § 1001 and 49 U.S.C. § 5307 on the Contractor, to the extent the Federal Government deems appropriate.

The Contractor agrees to include the above two clauses in each subcontract financed in whole or in part with Federal assistance provided by FTA. It is further agreed that the clauses shall not be modified, except to identify the subcontractor/subconsultant who will be subject to the provisions.

L. GOVERNMENT-WIDE DEBARMENT AND SUSPENSION.

This contract is a covered transaction for purposes of 2 CFR Parts 180. As such, the Contractor is required to verify that none of the Contractor, its principals, as defined at 2 CFR 180.995, or affiliates, as defined at 2 CFR 180.905, are excluded or disqualified as defined at 2 CFR 180.940 and 180.935.

The Contractor is required to comply with 2 CFR Part 180, Subpart C and must include the requirement to comply with 2 CFR Part 180, Subpart C in any lower tier covered transaction it enters into.

By signing and submitting its bid or proposal, Bidder certifies as follows:

The certification in this clause is a material representation of fact relied upon by the Authority. If it is later determined that the proposer knowingly rendered an erroneous certification, in addition to remedies available to the Authority, the Federal Government may pursue available remedies, including but not limited to suspension and/or debarment.

The bidder or proposer agrees to comply with the requirements of 2 CFR Part 180, Subpart C while this offer is valid and throughout the period of any contract that may arise from this offer. The bidder or proposer further agrees to include a provision requiring such compliance in its lower tier covered transactions.

M. CIVIL RIGHTS REQUIREMENTS.

The following requirements apply to the underlying contract:

1. Nondiscrimination - In accordance with Title VI of the Civil Rights Act, as amended, 42 U.S.C. § 2000d, section 303 of the Age Discrimination Act of 1975, as amended, 42 U.S.C. § 6102, section 202 of the Americans with Disabilities Act of 1990, 42 U.S.C. § 12132, and Federal transit law at 49 U.S.C. § 5332, the Contractor agrees that it will not discriminate against any employee or applicant for employment because of race, color, creed, national origin, sex, age, or disability. In addition, the Contractor agrees to comply with applicable Federal implementing regulations and other implementing requirements FTA may issue.
2. Equal Employment Opportunity - The following equal employment opportunity requirements apply to the underlying contract:
 - (a) Race, Color, Creed, National Origin, Sex - In accordance with Title VII of the Civil Rights Act, as amended, 42 U.S.C. § 2000e, and Federal transit laws at 49 U.S.C. § 5332, the Contractor agrees to comply with all applicable equal employment opportunity requirements of U.S. Department of Labor (U.S. DOL) regulations, "Office of Federal Contract Compliance Programs, Equal Employment Opportunity, Department of Labor," 41 CFR Parts 60 *et seq.*, (which implement Executive Order No. 11246, "Equal Employment Opportunity," as amended by Executive Order No. 11375, "Amending Executive Order 11246 Relating to Equal Employment Opportunity," 42 U.S.C. § 2000e note), and with any applicable Federal statutes, executive orders, regulations, and Federal policies that may in the future affect construction activities undertaken in the course of the Project. The Contractor agrees to take affirmative action to ensure that applicants are employed, and that employees are treated during employment, without regard to their race, color, creed, national origin, sex, or age. Such action shall include, but not be limited to, the following: employment, upgrading, demotion or transfer, recruitment or recruitment advertising, layoff or termination; rates of pay or other forms of compensation; and selection for training, including apprenticeship. In addition, the Contractor agrees to comply with any implementing requirements FTA may issue.
 - (b) Age - In accordance with section 4 of the Age Discrimination in Employment Act of 1967, as amended, 29 U.S.C. § 623 and Federal transit law at 49 U.S.C. § 5332, the Contractor agrees to refrain from discrimination against present and prospective employees for reason of age. In addition, the Contractor agrees to comply with any implementing requirements FTA may issue.

- (c) Disabilities - In accordance with section 102 of the Americans with Disabilities Act, as amended, 42 U.S.C. § 12112, the Contractor agrees that it will comply with the requirements of U.S. Equal Employment Opportunity Commission, "Regulations to Implement the Equal Employment Provisions of the Americans with Disabilities Act," 29 CFR Part 1630, pertaining to employment of persons with disabilities. In addition, the Contractor agrees to comply with any implementing requirements FTA may issue.
3. The Contractor also agrees to include these requirements in each subcontract financed in whole or in part with Federal assistance provided by FTA, modified only if necessary to identify the affected parties.

N. SAFE OPERATION OF MOTOR VEHICLES.

The Contractor is encouraged to adopt and promote on-the-job seat belt use policies and programs for its employees and other personnel that operate company-owned vehicles, company-rented vehicles, or personally operated vehicles. The terms "company-owned" and "company-leased" refer to vehicles owned or leased either by the Contractor or the Authority. The Contractor agrees to adopt and enforce workplace safety policies to decrease crashes caused by distracted drivers, including policies to ban text messaging while using an electronic device supplied by an employer, and driving a vehicle the driver owns or rents, a vehicle Contractor owns, leases, or rents, or a privately-owned vehicle when on official business in connection with the work performed under this agreement.

O. DAVIS-BACON ACT REQUIREMENTS.

A. Minimum wages

1. All laborers and mechanics employed or working upon the site of any qualifying construction work under the Contract (or under the United States Housing Act of 1937 or under the Housing Act of 1949 in the construction or development of the project), will be paid unconditionally and not less often than once a week, and without subsequent deduction or rebate on any account (except such payroll deductions as are permitted by regulations issued by the Secretary of Labor under the Copeland Act (29 CFR Part 3)), the full amount of wages and bona fide fringe benefits (or cash equivalents thereof) due at time of payment computed at rates not less than those contained in the wage determination of the Secretary of Labor which is attached hereto and made a part hereof, regardless of any contractual relationship which may be alleged to exist between the Contractor and such laborers and mechanics.

Contributions made or costs reasonably anticipated for bona fide fringe benefits under section I (b)(2) of the Davis-Bacon Act on behalf of laborers or mechanics are considered wages paid to such laborers or mechanics, subject to the provisions of Subsection (A)(4) of this Section; also, regular contributions made or costs incurred for more than a weekly period (but not less often than quarterly) under plans, funds, or programs which cover the particular weekly period are deemed to be constructively made or incurred during such weekly period. Such laborers and mechanics shall be paid the appropriate wage rate and fringe benefits on the wage determination for the classification of work actually performed, without regard to skill, except as provided in 29 CFR Part 5.5(a)(4). Laborers or mechanics performing work in more than one classification may be compensated at the rate specified for each classification for the time actually worked therein, provided that the employer's payroll records accurately set forth the time spent in each classification in which such work is performed. The wage determination (including any additional classification and wage rates conformed under paragraph (A)(4) of this section) and the

Davis-Bacon poster (WH- 1321) shall be posted at all times by the Contractor and its subcontractors at the site of the work in a prominent and accessible place where it can be easily seen by the workers.

2. Whenever the minimum wage rate prescribed in the Contract for a class of laborers or mechanics includes a fringe benefit which is not expressed as an hourly rate, the Contractor shall either pay the benefit as stated in the wage determination or shall pay another bona fide fringe benefit or an hourly cash equivalent thereof.

3. If the Contractor does not make payments to a trustee or other third person, the Contractor may consider as part of the wages of any laborer or mechanic the amount of any costs reasonably anticipated in providing bona fide fringe benefits under a plan or program, provided that the Secretary of Labor has found, upon the written request of the Contractor, that the applicable standards of the Davis-Bacon Act have been met. The Secretary of Labor may require the Contractor to set aside in a separate account assets for the meeting of obligations under the plan or program.

4. (a) The contracting officer shall require that any class of laborers or mechanics which is not listed in the wage determination and which is to be employed under the Contract shall be classified in conformance with the wage determination. The contracting officer shall approve an additional classification and wage rate and fringe benefits therefor only when the following criteria have been met:

(i) The work to be performed by the classification requested is not performed by a classification in the wage determination; and

(ii) The classification is utilized in the area by the construction industry;
and

(iii) The proposed wage rate, including any bona fide fringe benefits, bears a reasonable relationship to the wage rates contained in the wage determination.

(b) If the Contractor and the laborers and mechanics to be employed in the classification (if known), or their representatives, and the contracting officer agree on the classification and wage rate (including the amount designated for fringe benefits where appropriate), a report of the action taken shall be sent by the contracting officer to the Administrator of the Wage and Hour Division, Employment Standards Administration, Washington, DC 20210. The Administrator, or an authorized representative, will approve, modify, or disapprove every additional classification action within 30 days of receipt and so advise the contracting officer or will notify the contracting officer within the 30-day period that additional time is necessary.

(c) In the event the Contractor, the laborers or mechanics to be employed in the classification, or their representatives, and the contracting officer do not agree on the proposed classification and wage rate (including the amount designated for fringe benefits, where appropriate), the contracting officer shall refer the questions, including the views of all interested parties and the recommendation of the contracting officer, to the Administrator for determination. The Administrator, or an authorized representative, will issue a determination with 30 days of receipt and so advise the contracting officer or will notify the contracting officer within the 30-day period that additional time is necessary.

(d) The wage rate (including fringe benefits where appropriate) determined pursuant to Subsections (A)(4)(b) or (c) of this Section, shall be paid to all workers performing work in the classification under this Contract from the first day on which work is performed in the classification.

B. Withholding

The Authority shall upon its own action or upon written request of an authorized representative of the Department of Labor withhold or cause to be withheld from the Contractor under this Contract or any other Federal contract with the Contractor, or any other Federally-assisted contract subject to Davis-Bacon prevailing wage requirements which is held by the Contractor, so much of the accrued payments or advances as may be considered necessary to pay laborers and mechanics, including apprentices, trainees, and helpers, employed by the Contractor or any subcontractor the full amount of wages required by the Contract. In the event of failure to pay any laborer or mechanic, including any apprentice, trainee, or helper, employed or working on the site of the work (or under the United States Housing Act of 1937 or under the Housing Act of 1949 in the construction or development of the project), all or part of the wages required by the Contract, the Authority may, after written notice to the Contractor, sponsor, applicant, or owner, take such action as may be necessary to cause the suspension of any further payment, advance, or guarantee of funds until such violations have ceased.

C. Payrolls and basic records

1. Payrolls and basic records relating thereto shall be maintained by the Contractor during the course of the work and preserved for a period of three years thereafter for all laborers and mechanics working at the site of the work (or under the United States Housing Act of 1937, or under the Housing Act of 1949, in the construction or development of the project). Such records shall contain the name, address, and social security number of each such worker, his or her correct classification, hourly rates of wages paid (including rates of contributions or costs anticipated for bona fide fringe benefits or cash equivalents thereof of the types described in section 1(b)(2)(B) of the Davis-Bacon Act), daily and weekly number of hours worked, deductions made and actual wages paid. Whenever the Secretary of Labor has found under 29 CFR 5.5(a)(1)(iv) that the wages of any laborer or mechanic include the amount of any costs reasonably anticipated in providing benefits under a plan or program described in section 1(b)(2)(B) of the Davis-Bacon Act, the Contractor shall maintain records which show that the commitment to provide such benefits is enforceable, that the plan or program is financially responsible, and that the plan or program has been communicated in writing to the laborers or mechanics affected, and records which show the costs anticipated or the actual cost incurred in providing such benefits. Contractors employing apprentices or trainees under approved programs shall maintain written evidence of the registration of apprenticeship programs and certification of trainee programs, the registration of the apprentices and trainees, and the ratios and wage rates prescribed in the applicable programs.

2. (a) The Contractor shall submit weekly for each week in which any contract work is performed a copy of all payrolls to the Authority for transmission to the Federal Transit Administration. The payrolls submitted shall set out accurately and completely all of the information required to be maintained under 29 CFR 5.5(a)(3)(i), except that full social security numbers and home addresses shall not be included on weekly transmittals. Instead the payrolls shall only need to include an individually identifying number for each employee (e.g., the last four digits of the employee's social security number). This information may be submitted in any form desired. Optional Form WH-347 is available for this purpose from the Wage and Hour Division Web site at <http://www.dol.gov/esa/whd/forms/wh347instr.htm> or its successor site. The Contractor is responsible for the submission of copies of payrolls by all subcontractors. Contractors and subcontractors shall maintain the full social security number and current address of each covered worker, and shall provide them upon request to the Authority if the agency is a party to the contract, but the agency is not such a party, the contractor will submit them to the applicant, sponsor, or owner, as the case may be, for transmission to the

(write in name of agency), the contractor, or the Wage and Hour Division of the Department of Labor for purposes of an investigation or audit of compliance with prevailing wage requirements. It is not a violation of this section for a prime contractor to require a subcontractor to provide addresses and social security numbers to the prime contractor for its own records, without weekly submission to the sponsoring government agency (or the applicant, sponsor, or owner).

(b) Each payroll submitted shall be accompanied by a "Statement of Compliance," signed by the Contractor or subcontractor or his or her agent who pays or supervises the payment of the persons employed under the Contract and shall certify the following:

(i) That the payroll for the payroll period contains the information to be provided under §5.5(a)(3)(ii) of Regulations, 29 CFR Part 5, the appropriate information is being maintained under §5.5(a)(3)(i) of Regulations, 29 CFR Part 5, and that such information is correct and complete;

(ii) That each laborer or mechanic (including each helper, apprentice, and trainee) employed on the Contract during the payroll period has been paid the full weekly wages earned, without rebate either directly or indirectly, and that no deductions have been made either directly or indirectly from the full wages earned, other than permissible deductions as set forth in Regulations, 29 CFR Part 3;

(iii) That each laborer or mechanic has been paid not less than the applicable wage rates and fringe benefits or cash equivalents for the classification of work performed, as specified in the applicable wage determination incorporated into the Contract.

(c) The weekly submission of a properly executed certification set forth on the reverse side of Optional Form WH-347 shall satisfy the requirement for submission of the "Statement of Compliance" required by paragraph (C)(2)(b) of this Section.

(d) The falsification of any of the above certifications may subject the Contractor or subcontractor to civil or criminal prosecution under Section 1001 of Title 18 and Section 231 of Title 31 of the United States Code.

3. The Contractor or subcontractor shall make the records required under paragraph (3)(i) of this Section available for inspection, copying, or transcription by authorized representatives of the Federal Transit Administration or the Department of Labor, and shall permit such representatives to interview employees during working hours on the job. If the Contractor or subcontractor fails to submit the required records or to make them available, the Federal agency may, after written notice to the Contractor, sponsor, applicant, or owner, take such action as may be necessary to cause the suspension of any further payment, advance, or guarantee of funds. Furthermore, failure to submit the required records upon request or to make such records available may be grounds for debarment action pursuant to 29 CFR 5.12.

D. Apprentices and trainees

1. Apprentices - Apprentices will be permitted to work at less than the predetermined rate for the work they performed when they are employed pursuant to and individually registered in a bona fide apprenticeship program registered with the U.S. Department of Labor, Employment and Training Administration, Bureau of Apprenticeship and Training, or with a State Apprenticeship Agency recognized by the Bureau, or if a person is employed in his or her first 90 days of probationary employment as an

apprentice in such an apprenticeship program, who is not individually registered in the program, but who has been certified by the Bureau of Apprenticeship and Training or a State Apprenticeship Agency (where appropriate) to be eligible for probationary employment as an apprentice. The allowable ratio of apprentices to journeymen on the job site in any craft classification shall not be greater than the ratio permitted to the Contractor as to the entire work force under the registered program. Any worker listed on a payroll at an apprentice wage rate, who is not registered or otherwise employed as stated above, shall be paid not less than the applicable wage rate on the wage determination for the classification of work actually performed. In addition, any apprentice performing work on the job site in excess of the ratio permitted under the registered program shall be paid not less than the applicable wage rate on the wage determination for the work actually performed. Where Contractor is performing construction on a project in a locality other than that in which its program is registered, the ratios and wage rates (expressed in percentages of the journeyman's hourly rate) specified in the Contractor's or subcontractor's registered program shall be observed. Every apprentice must be paid at not less than the rate specified in the registered program for the apprentice's level of progress, expressed as a percentage of the journey hourly rate specified in the applicable wage determination. Apprentices shall be paid fringe benefits in accordance with the provisions of the apprenticeship program. If the apprenticeship program does not specify fringe benefits, apprentices must be paid the full amount of fringe benefits listed on the wage determination for the applicable classification. If the Administrator of the Wage and Hour Division of the U.S. Department of Labor determines that a different practice prevails for the applicable apprentice classification, fringes shall be paid in accordance with that determination. In the event the Bureau of Apprenticeship and Training, or a State Apprenticeship Agency recognized by the Bureau, withdraws approval of an apprenticeship program, the Contractor will no longer be permitted to utilize apprentices at less than the applicable predetermined rate for the work performed until an acceptable program is approved.

2. Trainees - Except as provided in 29 CFR 5.16, trainees will not be permitted to work at less than the predetermined rate for the work performed unless they are employed pursuant to and individually registered in a program which has received prior approval, evidenced by formal certification by the U.S. Department of Labor, Employment and Training Administration. The ratio of trainees to journeymen on the job site shall not be greater than permitted under the plan approved by the Employment and Training Administration. Every trainee must be paid at not less than the rate specified in the approved program for the trainee's level of progress, expressed as a percentage of the journeyman hourly rate specified in the applicable wage determination. Trainees shall be paid fringe benefits in accordance with the provisions of the trainee program. If the trainee program does not mention fringe benefits, trainees shall be paid the full amount of fringe benefits listed on the wage determination unless the Administrator of the Wage and Hour Division determines that there is an apprenticeship program associated with the corresponding journeyman wage rate on the wage determination which provides for less than full fringe benefits for apprentices. Any employee listed on the payroll at a trainee rate who is not registered and participating in a training plan approved by the Employment and Training Administration shall be paid not less than the applicable wage rate on the wage determination for the classification of work actually performed. In addition, any trainee performing work on the job site in excess of the ratio permitted under the registered program shall be paid not less than the applicable wage rate on the wage determination for the work actually performed. In the event the Employment and Training Administration withdraws approval of a training program, the Contractor will no longer be permitted to utilize trainees at less than the applicable predetermined rate for the work performed until an acceptable program is approved.

3. Equal employment opportunity. The utilization of apprentices, trainees and journeymen under this part shall be in conformity with the equal employment opportunity requirements of Executive Order 11246, as amended, and 29 CFR Part 30.

E. Compliance with Copeland Act requirements

The Contractor shall comply with the requirements of 29 CFR Part 3, which are incorporated by reference in this Contract.

F. Subcontracts

The Contractor or subcontractor shall insert in any subcontracts the clauses contained in 29 CFR 5.5(a)(1) through (10) and such other clauses as the Federal Transit Administration may by appropriate instructions require, and also a clause requiring the subcontractors to include these clauses in any lower tier subcontracts. The Contractor shall be responsible for the compliance by any subcontractor or lower subcontractor with all the contract clauses in 29 CFR 5.5.

G. Contract termination: Debarment

A breach of the contract clauses in 29 CFR 5.5 may be grounds for termination of the Contract and for debarment as a Contractor and a subcontractor as provided in 29 CFR 5.12.

H. Compliance with Davis-Bacon and Related Act requirements

All rulings and interpretations of the Davis-Bacon and Related Acts contained in 29 CFR Parts 1, 3, and 5 are herein incorporated by reference in this Contract.

I. Disputes Concerning Labor Standards

Disputes arising out of the labor standards provisions of this Contract shall not be subject to the general disputes clause of this Contract. Such disputes shall be resolved in accordance with the procedures of the Department of Labor set forth in 29 CFR Parts 5, 6, and 7. Disputes within the meaning of this clause include disputes between the Contractor (or any of its subcontractors) and the contracting agency, the U.S. Department of Labor, or the employees or their representatives.

J. Certification of eligibility

1. By entering into this Contract, the Contractor certifies that neither it (nor he or she) nor any person or firm who has an interest in the Contractor's firm is a person or firm ineligible to be awarded Government contracts by virtue of section 3(a) of the Davis-Bacon Act or 29 CFR 5.12(a)(1).

2. No part of this Contract shall be subcontracted to person or firm ineligible for an award of a government contract by virtue of section 3(a) of the Davis-Bacon Act or 29 CFR 5.12(a)(1).

3. The penalty for making false statements is prescribed in the U.S. Criminal Code, 18 U.S.C. 1001.

P. CONTRACT WORK HOURS AND SAFETY STANDARDS ACT.

A. Overtime Requirements – Neither the Contractor nor its subcontractors may

permit any laborer or mechanic in any workweek in which he or she is employed on such work under this Contract to work in excess of forty (40) hours in such workweek unless such laborer or mechanic receives compensation at a rate not less than one and one-half times the basic rate of pay for all hours worked in excess of forty hours in such workweek.

B. Violation, Liability for Unpaid Wages, Liquidated Damages – In the event of any violation of the clause set forth in paragraph A of this Section, the Contractor and any subcontractor responsible therefor shall be liable for the unpaid wages. In addition, Contractor and subcontractor shall be liable to the United States for liquidated damages. Such liquidated damages shall be computed with respect to each individual laborer or mechanic, including watchmen and guards, employed in violation of the clause set forth in paragraph A of this Section in the sum of \$25.0010.00 for each calendar day on which such individual was required or permitted to work in excess of the standard workweek of forty (40) hours without payment of the overtime wages required by the clause set forth in paragraph A of this Section.

C. Withholding for Unpaid Wages and Liquidated Damages – Authority shall upon its own action or upon written request of an authorized representative of the Department of Labor withhold or cause to be withheld from any moneys payable on account of work performed by Contractor under any such contract or any other Federal contract with Contractor or any other federally assisted contract subject to the Contract Work Hours and Safety Standards Act, which is held by Contractor, such sums as may be determined to be necessary to satisfy any liabilities of Contractor or subcontractor for unpaid wages and liquidated damages as provided in the clause set forth in paragraph B of this Section.

D. Subcontracts – The Contractor shall insert in any subcontract the clauses set forth in this Section and also a clause requiring the subcontractors to include these clauses in any lower tier subcontracts. The Contractor shall be responsible for compliance by any subcontractor or lower tier subcontractor with the clauses set forth in this Section.

E. Payrolls and Basic Records – Payrolls and basic records relating thereto shall be maintained by the Contractor during the course of the work and preserved for a period of three (3) years thereafter for all laborers and mechanics working at the site of the work (or under the United States Housing Act of 1937, or under the Housing Act of 1949, in the construction or development of the project). Such records shall contain the name, address, and social security number of each such worker, his or her correct classification, hourly rates of wages paid (including rates of contributions or costs anticipated for bona fide fringe benefits or cash equivalents thereof of the types described in Section 1(b)(2)(B) of the Davis-Bacon Act), daily and weekly number of hours worked, deductions made and actual wages paid. Whenever the Secretary of Labor has found under 29 CFR 5.5(a)(1)(iv) that the wages of any laborer or mechanic include the amount of any costs reasonably anticipated in providing benefits under a plan or program described in Section 1(b)(2)(B) of the Davis-Bacon Act, the Contractor shall maintain records that show that the commitment to provide such benefits is enforceable, that the plan or program is financially responsible, and that the plan or program has been communicated in writing to the laborers or mechanics affected, and shall also maintain records that show the costs anticipated or the actual cost incurred in providing such benefits. Should the Contractor employ apprentices or trainees under approved programs, it shall maintain written evidence of the registration of apprenticeship programs and certification of trainee programs, the registration of the apprentices and trainees, and the ratios and wage rates prescribed in the applicable programs.

F. Occupational Safety and Health Act – The Contractor agrees to comply with Section 107 of the Contract Work Hours and Safety Standards Act, 40 U.S.C. Section 333, and applicable DOL regulations, “Safety and Health Regulations for Construction”,

29 CFR Part 1926. Among other things, the Contractor agrees that it will not require any laborer or mechanic to work in unsanitary, hazardous, or dangerous surroundings or working conditions.

G. The Contractor also agrees to include the requirements of this Subsection F in each subcontract. The term "subcontract" under this Subsection is considered to refer to a person who agrees to perform any part of the labor or material requirements of a contract for construction, alteration or repair. A person who undertakes to perform a portion of a contract involving the furnishing of supplies or materials will be considered a "subcontractor" under this Section if the work in question involves the performance of construction work and is to be performed: (1) directly on or near the construction site, or (2) by the employer for the specific project on a customized basis. Thus, a supplier of materials that will become an integral part of the construction is a "subcontractor" if the supplier fabricates or assembles the goods or materials in question specifically for the construction project and the work involved may be said to be construction activity. If the goods or materials in question are ordinarily sold to other customers from regular inventory, the supplier is not a "subcontractor." The requirements of this Section do not apply to contracts or subcontracts for the purchase of supplies or materials or articles normally available on the open market.

Q. INCORPORATION OF FEDERAL TRANSIT ADMINISTRATION (FTA) TERMS.

The preceding provisions include, in part, certain Standard Terms and Conditions required by U.S. DOT, whether or not expressly set forth in the preceding contract provisions. All contractual provisions required by the U.S. DOT, as set forth in FTA Circular 4220.1F, dated November 1, 2008 as may be amended, are hereby incorporated by reference. Anything to the contrary herein notwithstanding, all FTA mandated terms shall be deemed to control in the event of a conflict with other provisions contained in this Contract. The Contractor shall not perform any act, fail to perform any act, or refuse to comply with any the Authority requests which would cause the Authority to be in violation of the FTA terms and conditions.

41. UNFORSEEN CONDITIONS

As required by California Public Contract Code, Section 7104:

- A. The Contractor shall promptly, and before the following conditions are disturbed, notify the Authority, in writing, of any:
1. Material that the Contractor believes may be material that is hazardous waste, as defined in Section 25117 of the Health and Safety Code that is required to be removed to a Class I, Class II, or Class III disposal site in accordance with provisions of the existing law.
 2. Subsurface or latent physical conditions at the site differing from those indicated.
 3. Unknown physical conditions as the site of any unusual nature, different materially from those ordinarily encountered and generally recognized as inherent in the nature of the work, provided for in the Contract.
- B. The Authority shall promptly investigate the conditions, and if it finds that the conditions do materially so differ, or do involve hazardous waste, and cause a decrease or increase in the Contractor's cost of, or the time required for,

performance of any part of the work shall issue a work modification order under the procedures described in the Contract.

- C. In the event that a dispute arises between the Authority and the Contractor whether the conditions materially differ, or involve hazardous waste or cause a decrease or increase in the Contractor's cost of, or time required for, performance of any part of the work, the Contractor shall not be excused from any scheduled completion date provided for by the Contract, but shall proceed with all work to be performed under the Contract. The Contractor shall retain any and all rights provided either by Contract or by law which pertain to the resolution of disputes and protests between the contracting parties.

42. ANTI-TRUST CLAIM ASSIGNMENT

The Bidder is required to comply with Public Contract Code Section 7103.5(b), which addresses assignment of antitrust actions.

43. BID PACKAGE

Required documents that must be submitted at the time of the bid opening are:

- A. Bid Forms, Acknowledgment of Terms and Conditions and Schedule of Bid Prices, pages B-1 - 2 (Special Provision 9 & 10)
- B. Bidder's Bond, page B-3; or Irrevocable Standby Letter of Credit, sample page B-5; or Certified Cashiers Check, (General Condition 8, Special Provision 12)
- C. List of References, pages B-7 & 8 (Special Provision 4)
- D. Non-Collusion Declaration, page B-9 (Special Provision 32)
- E. Disqualification Questionnaire, page B-10 (Special Provision 30)
- F. DBE Questionnaire, page B-13 & 14 (Special Provision 22)
- G. Designation of Subcontractors and Sub-Bidders, page B-15 & 16 (Special Provision 21)
- H. Lobbying Certification For Contracts Grants, Loans And Cooperative Agreements, pages B-18,B-19, & B-20. Instructions on page B-21 (Special Provision 40)
- I. Buy America Certification, page B-22 (Special Provision 40)

Required documents that must be completed by the successful bidder are listed below:

- A. Agreement
- B. Performance Bond (Special Provision 15)
- C. Payment Bond (Special Provision 15)
- D. Certificate of Insurance (Special Provision 16)

Samples of the Agreement, Certificate of Insurance and Payment Bond and Performance Bond are attached hereto.

1. GENERAL

It is the intent of these specifications to describe the Authority's requirements for the demolition and removal of four bus shelters in Livermore, CA, and the relocation of two shelters in Livermore, CA, and two shelters in Pleasanton, CA, in accordance with these specifications and as more particularly described in the Technical Specifications which are included herewith.

2. CONFORMITY

All bidders must conform to these specifications, and the service they provide shall be of first class quality and shall be the best obtainable in the trades. The services required under this Contract shall comply with all OSHA, Federal, State, and Local regulations pertaining to the performance and application of said services, which includes all licenses and permits to perform the required services.

3. RESPONSIBILITY

The Contractor shall assume responsibility for all services associated with this Contract, whether they are provided by the Contractor or a subcontractor of its selection.

4. CLEAN UP

During the progress of the work the Contractor shall keep the work area in a neat condition and shall dispose of refuse as often as directed or as may be necessary to maintain a work area free of any unsightly accumulation of debris or rubbish. At a minimum, the work area will be cleaned up at the end of each workday. Final Acceptance of the work will include the returning of the work area to the level of cleanliness when the work commenced.

5. USE OF PREMISES

The work shall be performed in such a manner as to eliminate unnecessary noise, obstructions and other annoyances to nearby occupants. The Contractor will not encumber the premises with materials, equipment or vehicles except as mutually agreed with the Authority Contract Administrator. No business advertisement signs will be permitted. All utility vehicles that operate on LAVTA property will require a flashing amber light or flag during construction.

6. OTHER

- a) LAVTA will provide initial review to the successful bidder on each element of the project, however, LAVTA will expect successful bidder to deliver remainder of project with minimal inspections and supervision.
- b) In the event of a spill of diesel fuel, other petroleum products or hazardous materials, either as a result of work performed by the Contractor or other non-related activities at the Authority facilities, the Contractor may be required to perform clean-up activities, including removal of contaminated soils or other materials. These clean-up activities shall be performed in accordance with applicable OSHA, Federal, State and Local regulations, laws and guidelines. Refer to Special Provision 38.
- c) Any suggested changes to the plans, work schedules or materials shall be reported immediately to the Authority Contract Administrator, with a written notice to follow within 24 hours that details the situation. The Authority, after having been properly notified, may choose to accept or reject the suggested change at its sole discretion- either choice will be communicated in writing. No extension of the completion date will be made unless clearly agreed to by both parties and evidenced in writing. Refer to General Condition 34.

^^

4 SCOPE OF WORK

Add to section **4-1.01:**

LAVTA owns and maintains numerous bus shelters throughout its service area, which includes both, Livermore, CA, and Pleasanton, CA. The scope of this project includes the relocation of four existing shelters and their amenities (including, but not limited to, benches, bike racks, signs, and lights) from existing bus stops in Livermore, CA, to four new bus stops that will be demolished and reconstructed as part of this contract, also within Livermore, CA. Two of these Rapid-style shelters and amenities to be relocated are currently located at the San Francisco Premium Outlets on West Jack London Boulevard in Livermore, CA. The other two Rapid-style shelters and amenities are currently located at Stoneridge Shopping Center on Stoneridge Drive in Pleasanton, CA.

^^

5 CONTROL OF WORK

Replace section **5-1.02 CONTRACT COMPONENTS** with:

A component in one Contract part applies as if appearing in each. The parts are complementary and describe and provide for a complete work.

If a discrepancy exists:

1. The governing ranking of Contract parts in descending order is:
 - 1.1. General Conditions & Instructions to Bidders
 - 1.2. Special Provisions
 - 1.3. Technical Specifications
 - 1.4. Project plans
 - 1.5. Standard specifications (as revised by the Revised Standard Specifications)
 - 1.6. Revised standard plans
 - 1.7. Standard plans
 - 1.8. City of Livermore and Pleasanton Standard Specifications and Details
 - 1.9. Supplemental project information
2. Written numbers and notes on a drawing govern over graphics
3. A detail drawing governs over a general drawing
4. A detail specification governs over a general specification
5. A specification in a section governs over a specification referenced by that section

If a discrepancy is found or confusion arises, submit an RFI.

Add to section **5-1.20B(1):**

The work is located within the right-of-way of the cities of Livermore and Pleasanton.

You must acquire encroachments permits, and any applicable building permits, from the City of Livermore and the City of Pleasanton to perform your work. Pay all fees associated with acquiring these permits. You must comply with the requirements of each permits. Familiarize yourself with each city's requirements prior to bidding.

Acquire a business license from each City.

City of Pleasanton's encroachment permit information is located at:

<http://www.cityofpleasantonca.gov/gov/depts/cd/permit/process/encroachment.asp>

City of Livermore encroachment permit information is located at:

<http://www.cityoflivermore.net/citygov/cdd/permits/applications.htm>

The work within Pleasanton is within the Hacienda Business Park. Coordinate with James Paxson, General Manager of the Hacienda Business Park. The City of Pleasanton will require a written approval from the Hacienda Business Park before they will issue an encroachment permit. Mr. Paxson's contact info is:

4305 Hacienda Drive, Suite 330
Pleasanton, CA 94588
(925) 734-6500 (main)
(925) 734-6510 (direct)
james@hacienda.org

Coordinate and comply with each city's requirements, including, but not limited to, hours of work and traffic control.

Work associated with acquiring city encroachment permits, building permits, and business licenses, including payment of all fees, and complying with the requirements of the permits and licenses, is paid for as ENCROACHMENT PERMITS (LIVERMORE AND PLEASANTON).

The Cities of Pleasanton and Livermore will each require inspection by their staff as a condition of their encroachment permit. Inspection fees will be charged by each city. The contract includes an inspection budget from which you will be reimbursed for actual costs paid for inspection services, up to a maximum amount of \$10,000. Inspection costs in excess of \$10,000 will be at your expense, and will not be reimbursed by LAVTA.

Replace section **5-1.26** with:

LAVTA is not providing construction staking services for this contract. You are responsible for providing all necessary construction surveys. Construction surveys shall be done in accordance with Chapter 12, "Construction Surveys," of the California Department of Transportation's Survey Manual. All work shall be constructed to the lines and grades shown on the contract drawings. Unless authorized by the Engineer, any work done without construction survey line and grade will be done at the Contractor's risk.

Construction surveying is paid for as CONTRACTOR CONSTRUCTION STAKING.

Add to section **5-1.27A General**:

Make a record of changes during construction on one set of prints of the plans and specifications provided by the Engineer for this purpose. This set of documents shall be kept at the job site and shall be used only for marking as-built conditions. Upon completion of the project, deliver these documents to the Engineer prior to the processing of the final estimate.

See General Note 28 on Sheet GN-01 for additional as-built requirements.

Payment for all work associated with as-builts is considered as included in the price paid for the various contract bid items and there will be no separate payment.

Add to section **5-1.36**:

5-1.36E Survey Monuments

Protect survey monuments. Upon discovery of a survey monument, immediately:

1. Stop work near the monument
2. Notify the Engineer

Do not resume work near the monument until authorized.

Documents.

- 5. Promptly notify Engineer and Contractor of observed irregularities or non-conformance of Work or products.
 - 6. Perform additional tests required by Engineer.
 - 7. Attend pre-construction meetings and progress meetings.
- I. Testing Agency Reports: After each test, promptly submit copies of the report to the Engineer, as specified herein. When requested by Engineer, provide interpretation of test results. At minimum, include the following in reports:
 - 1. Date Issued.
 - 2. Project title and number.
 - 3. Name of inspector.
 - 4. Date and time of sampling or inspection.
 - 5. Identification of product and specifications section.
 - 6. Location in the Project.
 - 7. Type of inspection or test.
 - 8. Date of test.
 - 9. Results of tests.
 - 10. Conformance with Contract Documents.
 - J. Limits On Testing Agency's Authority:
 - 1. Agency or laboratory may not release, revoke, alter, or enlarge on requirements of Contract Documents.
 - 2. Agency or laboratory may not approve or accept any portion of the Work.
 - 3. Agency or laboratory may not assume any duties of Contractor.
 - 4. Agency or laboratory has no authority to stop the Work.

Testing and inspection services are paid for as CONTRACTOR-HIRED TESTING AGENCY.

7 LEGAL RELATIONS AND RESPONSIBILITY TO THE PUBLIC

Add to section **7-1.02K(5)**:

Work shall be restricted to between the hours of 8:00 am to 5:00 pm, Monday through Friday, or as required by Encroachment Permits from Cities of Pleasanton and Livermore. Work shall not be allowed outside this work window, including on Saturday or Sunday, unless approved in advance and in writing by the City of Livermore or the City of Pleasanton. Contractor shall submit requests for extending or modifying the working hours to the

Engineer in writing.

Add to section 7-1.03 PUBLIC CONVENIENCE:

Maintain pedestrian access along the streets adjacent to bus stop. If work requires closing of the sidewalk, direct pedestrians to the other side of the street using pedestrian directional signage. Do not close the sidewalk on both sides of the street within the same block. If necessary to maintain pedestrian access, provide a temporary pedestrian path through or around the construction site.

Prior to starting construction, provide written notification to the public, including businesses adjacent to the project locations, local utility companies, and any other persons or agencies affected by this project.

You must maintain an ADA-compliant pedestrian path of travel along North Canyons. If you elect to perform construction activities at the eastbound Constitution Drive stop and the westbound Independence Drive stop at the same time, you must provide an ADA-compliant temporary pedestrian path at one of the two sites.

You will be permitted to close the following bus stops while construction is underway. During the closure, the full width of the bus pad will be available for your use during working hours, subject to any restrictions placed by the City.

- North Canyons at Constitution Drive (NB and SB)
- North Canyons at Independence Drive (NB and SB)
- Stoneridge Drive and Pleasant Hill Road
- Springdale Avenue and Kaiser Permanente Entrance

You will not be permitted to close the bus stops on West Jack London Boulevard. They must remain open during construction. Maintain ADA-compliant pedestrian access through the construction area. You will be permitted to close and use the front 32 feet of each bus pad for construction, measured from the start of the tangent curb at the front of each platform. The remainder of the bus pad will be left open and utilized by LAVTA to maintain serve at these two bus stops. Review the bus pad area to be closed with LAVTA prior to closing and occupying it.

Place temporary signage at each bus stop to direct transit rides to the temporary stops, in accordance with the following:

- Constitution Drive, direct passengers East to a temporary stop to be located at 455 N Canyons (westbound) and across the street from 455 N Canyons (eastbound).
- Independence Drive, direct passengers West to the temporary stops at 455 N Canyons, and East to temporarily reactivated stops at Comcast Place/Triad.
- Springdale Avenue and Kaiser, direct passengers to a temporary stop immediately south of the construction area.
- Stoneridge Drive and Pleasant Hill Road, this location is inactive and will require no closure and no signage.

Submit draft signage language and layout to the Engineer for review and approval prior to producing and installing signs. Temporary signage must be in place prior to closing the bus stop and starting work at that location.

Notify LAVTA 72 hours prior to closing a bus stop.

Do not close a sidewalk or begin demolition work until you have acquired and have on-hand all materials necessary to construct foundations and the sidewalk.

Add to section 7-1.04 PUBLIC SAFETY:

Prepare a Traffic Control Plan for each work location (bus stop) and when requested by the Engineer for any specific construction activity. In addition to vehicular traffic, the Traffic Control Plan shall also address movement of pedestrians though and around the work areas. The Traffic Control Plan shall be prepared by a person who is certified by the Institute of Transportation (ITS), the American Traffic Safety Services Association (ATSSA), the International Municipal Signal Association (IMSA) or the State of California Department of Transportation (Caltrans) as having successfully completed training in the design and operation of work zone traffic control. Along with the Traffic Control Plan, submit the designer's Certification. Work shall not proceed without the Engineer's advance approval of the Traffic Control Plan for the work attempted.

Submit the Traffic Control Plan (TCP) to the Engineer for review at least 10 working days prior to mobilization.

The Cities of Pleasanton and Livermore will require a TCP and will review and provide comments. Respond to their comments and resubmit as necessary until they approve your TCP.

^^

8 PROSECUTION AND PROGRESS

Add to section **8-1.10A:**

Liquidated damages are calculated from the table in this section.

^^

9 PAYMENT

Add to section **9-1.03:**

The bid items are intended to completely cover all work within the plans and specifications. Any work that is not clearly embraced in the various contract bid items is considered as included in the various contract items of work, and no additional compensation will be made.

Add to section **9-1.16D:**

The lump sum price for "Mobilization" shall include all mobilizations, remobilizations, and demobilizations.

^^

DIVISION II GENERAL CONSTRUCTION

10 GENERAL

Replace **section 10-7** with:

10-7 RAPID Bus Shelters and Amenities

The original Rapid bus stop details are included in the Appendix to these Technical Specifications.

You are responsible for reviewing, marking, and tracking all pieces through the disassembly and reassembly process to ensure items are tracked and correctly reconstructed.

Immediately notify the Engineer of any lost or missing parts. LAVTA will replace missing parts prior to the start of your work. You are responsible for replacement of lost parts once disassembly begins. Lost parts must be replaced with original manufacturer parts and pieces.

Protect the shelter during disassembly, transport, temporary storage, reassembly. Damage to the shelter must be repaired to the satisfaction of LAVTA.

Provide a Relocation Plan to the Engineer that describes how you intend to relocate the shelters.

LAVTA furnishes the bike racks. You are responsible for acquiring the hardware to install the bike racks.

The work to install the bike rack, including acquiring the necessary hardware, is paid for as INSTALL RAPID BIKE RACK (LAVTA FURNISHED).

12 TEMPORARY TRAFFIC CONTROL

Add to **section 12-4.02A:**

Comply with the traffic control requirements from the City of Pleasanton and the City of Livermore for work within each city.

Lane closures are not permitted. Maintain the existing lane configurations, with a minimum lane width of 11 feet.

The full width of the traveled way must be open for use by public traffic on Saturdays, Sundays and designated legal holidays; after 3:00 p.m. on Fridays and the day preceding designated legal holidays; and when construction operations are not actively in progress.

Personal vehicles of your employees must not be parked on the traveled way, including sections closed to traffic.

Emergency Response vehicles are permitted to pass through the work area without delay at all times.

When entering or leaving roadways which bear public traffic, the construction vehicles and equipment, whether empty or loaded, must in all cases yield to public traffic.

AA

15 EXISTING FACILITIES

Add to **section 15-1.01:**

The location of all existing underground utilities may not be shown on the Plans. It is not the intent of the plans to show the exact location of existing or relocated utilities. Do not assume that all utilities have been identified on the plans. You are responsible for verifying the actual location and depth in the field of all utilities.

Be cognizant of the existing overhead and underground utility lines in the proximity of the work area and take all precautions, as necessary, to not disturb these facilities.

Notify Underground Service Alert prior to any excavation. Call 811 and follow the USA North's California Excavation Manual and the specifications. Prior to starting an excavation, examine the excavation site for physical evidence (manholes, valve covers, water meters, fire hydrants, sewer cleanouts, storm drains, vaults, utility maintenance boxes, pole risers, trench cuts etc.) that would indicate the existence of underground facilities. You must excavate, as cautiously and prudently as possible.

Where excavations are performed in the vicinity of underground utility mains and/or services, perform initial hand dug exploratory excavations to determine their exact depth and location. Exercise extreme care to avoid

damage to all utility facilities. It is your responsibility to make repairs to any facilities damaged by your operation, at your cost.

Add to **section 15-1.03C:**

Remove and Dispose of Existing Non-Rapid Shelters

Remove and dispose of the existing non-Rapid shelters at the four (4) bus stops along North Canyons Parkway. These shelters become your property and must be disposed of outside the right-of-way.

Disconnect existing electrical service to the shelter.

This work is paid for as REMOVE AND DISPOSE OF EXISTING BUS STOP SHELTER.

Relocate Existing RAPID Bus Stop Shelters and Amenities

Existing bus stop shelters and amenities, where shown to be relocated or salvaged, shall be removed and either relocated or salvaged, per the plans.

All RAPID items are to be relocated except for the bike racks and the wayfinding signs. These are to be salvaged.

Items that are not to be relocated will be salvaged, packaged, and delivered to LAVTA's maintenance yard at 875 Atlantis Court, Livermore, CA. Provide the Engineer with a minimum of 2 working days advance notice prior to scheduling a drop-off.

Shelters and amenities to be relocated may be temporarily stored at LAVTA's maintenance yard at 875 Atlantis Court, Livermore, CA, for up to 28 calendar days. Provide the Engineer with a minimum of 2 working days advance notice for scheduling access to the maintenance yard.

Comply with Section 10 of these Specifications regard relocating and installing Rapid shelters and amenities.

At the locations where bus stop amenities are removed, grind the existing anchor bolts to a point 1" below the existing sidewalk surface, and fill with epoxy or grout that matches the color of the sidewalk.

Remove the foundation for the Rapid Bus Stop Flag Pole and Signage. Backfill and compact with aggregate base. Sawcut, remove, and replace the complete flag of sidewalk around the removed foundation. Replace with platform sidewalk. Payment for removal of the foundation is included in the cost for relocate rapid column-mounted flag sign (including foundation). Replacement of platform sidewalk is paid as Minor Concrete (Platform).

Remove and replace the existing bus stop name sign on each of the Rapid Bus Stop Flag Poles. LAVTA provides you with the replacement signs to be installed. Install the signs in an identical manner as the existing signs are attached. Existing sign attachment plans are shown in the Appendix. Payment for this work is included in the RELOCATE RAPID COLUMN-MOUNTED FLAG SIGN (INCLUDING FOUNDATION) bid item.

At the locations to receive the relocated improvements, excavate and place foundations as shown on the plans for those items requiring foundations. Perform this work as specified elsewhere in these specifications.

The work to relocate the existing Rapid shelter is paid for as RELOCATE RAPID SHELTER (INCLUDING FOUNDATION) and includes the costs to excavate and place the foundations necessary for the shelter, and all other work to completely relocate the shelter.

The work to relocate and install the existing Rapid real time sign is paid for as INSTALL SALVAGED STANDARD ELECTRONIC REAL-TIME INFORMATION SIGN.

The work to relocate the existing Rapid bench is paid for as RELOCATE RAPID BENCH.

The work to relocate the existing Rapid trash and recycling receptacle set is paid for as RELOCATE RAPID

Add to **section 20-1.01A**

At the four stops along North Canyons Parkway, restore the areas behind the back of sidewalk where existing sidewalk (bus platform) is removed and new platform is not constructed in its place.

Backfill this area as described in Section 19 of these Specifications. Place mulch to match existing.

Payment for restoring the landscaping area associated with the four areas of sidewalk/bus platform removal is considered as included in the prices paid for the various contract items of work. No separate payment will be made.

^^

DIVISION VIII MISCELLANEOUS CONSTRUCTION

73 CONCRETE CURBS AND SIDEWALKS

Add to **section 73-1.01:**

All concrete work within the City of Livermore (at the four new Rapid stops on North Canyons) shall comply with the City of Livermore's Standard Specifications, including Division 03-Concrete, available at:

<http://www.ci.livermore.ca.us/citygov/cd/eng/specs.asp>

All concrete work within the City of Pleasanton (patching the location of the removed column-mounted flag sign foundation, at the four exiting Rapid stops) shall comply with the City of Pleasanton's Standard Specifications, including Section 15 Concrete Improvement, available at:

<http://www.cityofpleasantonca.gov/civicax/filebank/blobdload.aspx?BlobID=28995>

You are responsible for providing Quality Assurance testing. Perform strength and slump tests of concrete. See section 6-2.01A.

Add to **section 73-1.03A:**

Do not place concrete when base surface temperature is less than 40 degrees F, or surface is wet or frozen.

You are required to raise or lower all existing facilities such as meter boxes, gate valve covers, sanitary sewer clean out covers, manholes, and monuments to finished grade for new pavement or sidewalk.

You must keep a log, which shall be submitted to the Engineer, of the number of existing facilities adjusted to grade. Note the location of the facilities within the paved limits. The log shall be submitted with each invoice request and at the end of the project.

Notify and coordinate with municipal utility agencies and private utility companies as indicated on the plans to obtain materials and requirements for adjusting facilities to grade.

Replace all utility boxes, lids, and covers damaged as a result of your activity.

Add to **section 73-1.04:**

Payment for raising or lowering any existing facilities as part of sidewalk or platform construction is included in payment for that item. There will be no separate payment for adjustment work.

Add to **section 73-4.01A:**

Construction of platform concrete is covered by this section.

Add to **section 73-4.01C:**

Submit to the Engineer a minimum of four (4) samples of decorative concrete paving with Oyster shell content and finishes as described elsewhere in section 73. Samples shall demonstrate the contrast between the trowel

and different sandblast finishes and between different amounts of crushed oyster shell content in the concrete's fine aggregate component. The submitted samples shall be as follows:

- Sample #1: 4% oyster shell content and trowel/medium sandblast finish
- Sample #2: 4% oyster shell content and trowel/heavy sandblast finish
- Sample #3: 8% oyster shell content and trowel/medium sandblast finish
- Sample #4: 8% oyster shell content and trowel/heavy sandblast finish

Prepare additional samples at the discretion of the Engineer.

Add to **section 73-4.02:**

Obtain cementitious material from the same source throughout the project.

Coarse aggregate shall be a combination of uniformly graded and clean gravel, crushed gravel, or crushed rock. All coarse aggregate shall have a maximum size 1" and be free from vegetable matters, and other deleterious substances, of approved source, and conform to ASTM C33.

Fine Aggregate shall be natural sand or a combination of not less than 50% natural and manufactured sand, free from deleterious coatings, roots, bark sticks, rags, and other extraneous material. Include 4% or 8% crushed oyster shells (mother of pearl) in the aggregate mix. Shells shall be washed crushed, screened, and then uniformly blended with the sand. The Engineer determines the precise percentage of crushed shell content to be used from the submitted samples (see section 73-4.01C).

Add to **section 73-4.03:**

Tool the edges of all joints in pavements. Joints to be placed at the locations indicated on the plans.

Finish shall be medium sweated finish and be monolithic with structural slab. Compact freshly placed slab and screed uniformly to grade. Lightly push large aggregate below the surface with screen tamper, screed and bull float. As soon as the surface becomes workable, wood float, then trowel to a uniform smooth surface. Follow by establishing the following two finishes:

Non-directional, even, and uniform medium sweated trowel finish.

Sandblast finish: Sandblast surfaces as indicated on the plans using a wet abrasive blast in such a manner that the resulting surfaces have a uniform appearance and texture. Sandblasting method and level must match the approved samples (see section 73-4.01C), in which the contrasts of the proposed sandblast and trowel finish are similar to that which will be achieved on the job, as selected by the Engineer. Method of execution must be approved by the Engineer.

Immediately after placement, protect pavement from premature drying, excessive hot or cold temperatures, and mechanical injury.

Do not permit vehicular traffic over pavement for 7 days minimum after finishing.

Replace **section 73-4.04** with:

Work to place and finish platform concrete is paid for as MINOR CONCRETE (PLATFORM).

DIVISION X ELECTRICAL WORK

86 GENERAL

Add to **section 86-1.01**:

LAVTA furnishes two (2) Rapid pedestrian lights. The remainder will be relocated.

Add to **section 86-1.02B(1)**:

All conduit within this project shall be Type 3, and sized per Plan.

Add to **section 86-1.02C(1)**:

Pull boxes within this project shall be marked with "ELECTRICAL" on pull box lid.

Add to **section 86-1.02M**:

Photo electric units within this project be Control Type II.

Replace **section 86-1.04** with:

The work to install new rapid pedestrian light furnished by LAVTA, including the costs to excavate and place the foundation, is paid for as INSTALL RAPID PEDESTRIAN LIGHT (INCLUDING FOUNDATION, LAVTA, FURNISHED).

This is a revocable bid item, and is not subject to the provisions of section 9-1.06.

87 ELECTRICAL SYSTEMS

Add to **section 87-1.03F(1)**:

Connection to existing conductors shall be made with a dual pole inline fuse.

Add to **section 87-21.03B(1)**:

Contractor shall maintain existing electrical service at each bus stop and reuse for modified bus stop configuration. Existing service is a direct connection to PG&E on an unmetered service. Contractor shall be responsible for coordination with PG&E for temporary disconnect and reconnection during construction.

APPENDICES

APPENDIX A – Original Bus Stop Amenity Procurement Plans (excerpt)

ARCHITECTURAL DRAWINGS

FILE INFO: F:\07002-JAVA-Rie0-BRT\000ADD\A111.dwg XREFS:XTBLK; XELEV-SECT-BASIC; XFPL-BASIC; XGRID-BASIC; XELEV-BASIC; XELEV-POLE; XTBLK-Phase 1; XTBLK-Procurement PLOTTED: May 07, 2009 11:12am By:bernard

SHEET NOTES

- ALL FINISHES TO BE FURNISHED BY MFR., U.O.N. PROVIDE ADDITIONAL PAINT FOR TOUCH UP AFTER INSTALLATION BY OTHERS.
- NOT USED.
- PROVIDE ACCESS FOR WIRING PV SYSTEM & ELECTRONIC SIGN SYSTEM WHERE MOUNTED ON FLAG SIGNS. ALLOW FOR WIRING TO BE CONCEALED IN STRUCTURE WHERE POSSIBLE. WIRING BY OTHERS.
- SEE A601 SIGNAGE SCHEDULE FOR LOCATIONS W/ PV & ELECTRIC SIGN.
- FOR LOCATIONS WHERE NO NEW SHELTER OCCURS, LOCATION SIGN TO BE MOUNTED ON FLAG SIGN.
- PROVIDE MOUNTING STRUCTURE FOR PHOTO VOLTAIC PANEL & BATTERY SYSTEM WHERE OCCURS TO POWER ELECTRONIC SIGN.
- OWNER TO FURNISH TO FLAG SIGN FABRICATOR, THE REQUIRED DIMENSIONS OF BATTERY & CONTROL ENCLOSURE PRIOR TO FABRICATION.
- FLAG SIGN STRUCTURE TO BE ENGINEERED TO WITHSTAND WIND LOADS OF PV PANELS @ LOCATIONS NOTED ON A601 TO RECEIVE PV POWER FOR ELECTRONIC SIGN SYSTEM. ELECTRONIC SIGN WITH PV SYSTEM BY OTHERS.

FINISH

- 1 METALIC SILVER COATING
- 2 CLEAR COAT @ SIGNS

VBN BUILDING
 560 14th St.
 Oakland, CA
 94612
 Tel: (510) 763-1313
 Fax: (510) 465-1586

LICENSED ARCHITECT
 ELEAZER NAOR
 C 17923
 EXP: 5/31/07
 STATE OF CALIFORNIA



MAY 8, 2009
 ISSUES/REVISIONS

NO.	DATE	DESCRIPTION

RAPID BUS STOP IMPROVEMENTS PROCUREMENT

DRAWN BY: VL/PN/BNL	DESIGNED BY:	CHECKED BY: JA	APPROVED BY:
PROJECT NUMBER: 097447005			SCALE: 1/4" = 1'-0"

PLAN / ELEVATIONS FLAG SIGNS

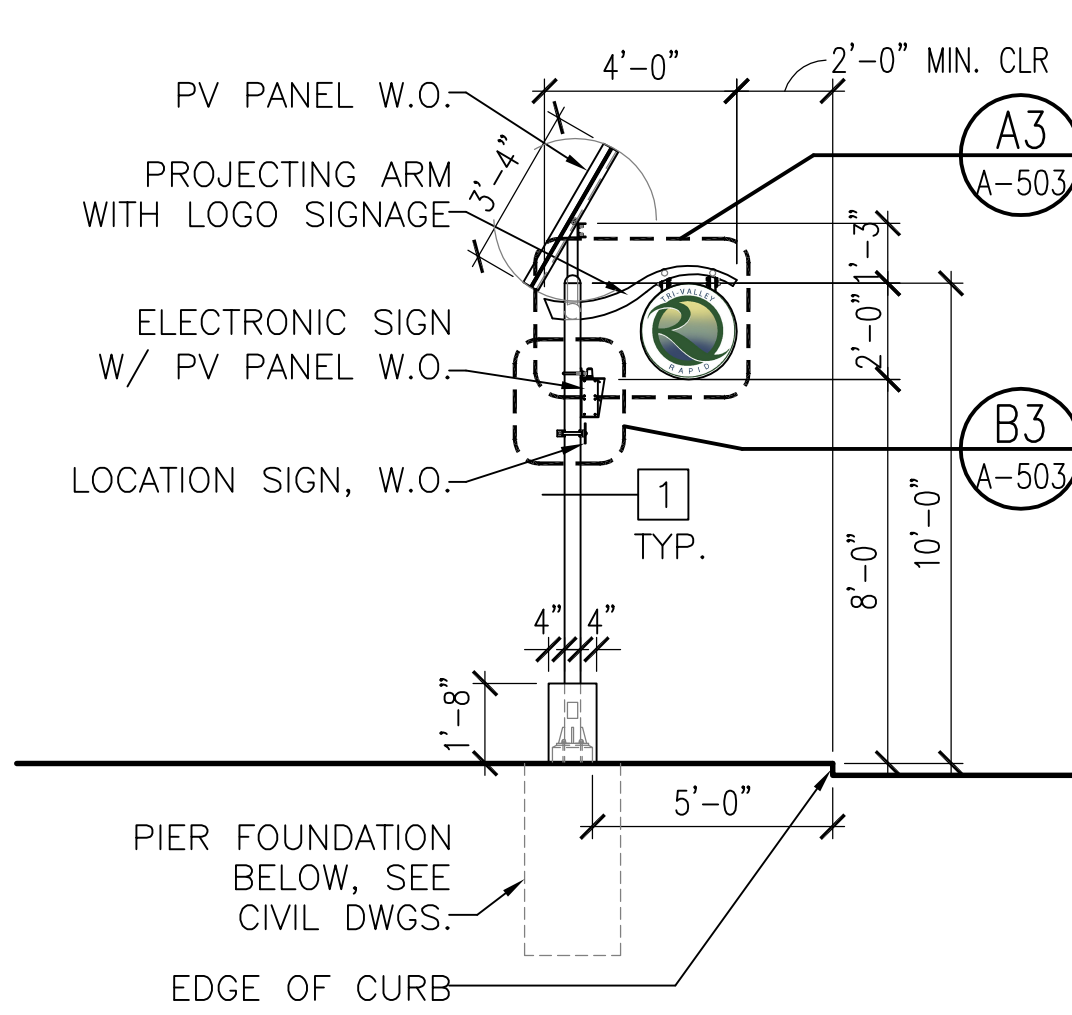

B1 SIDE ELEVATION W/ PV
 A-111 SCALE: 1/4"=1'-0"

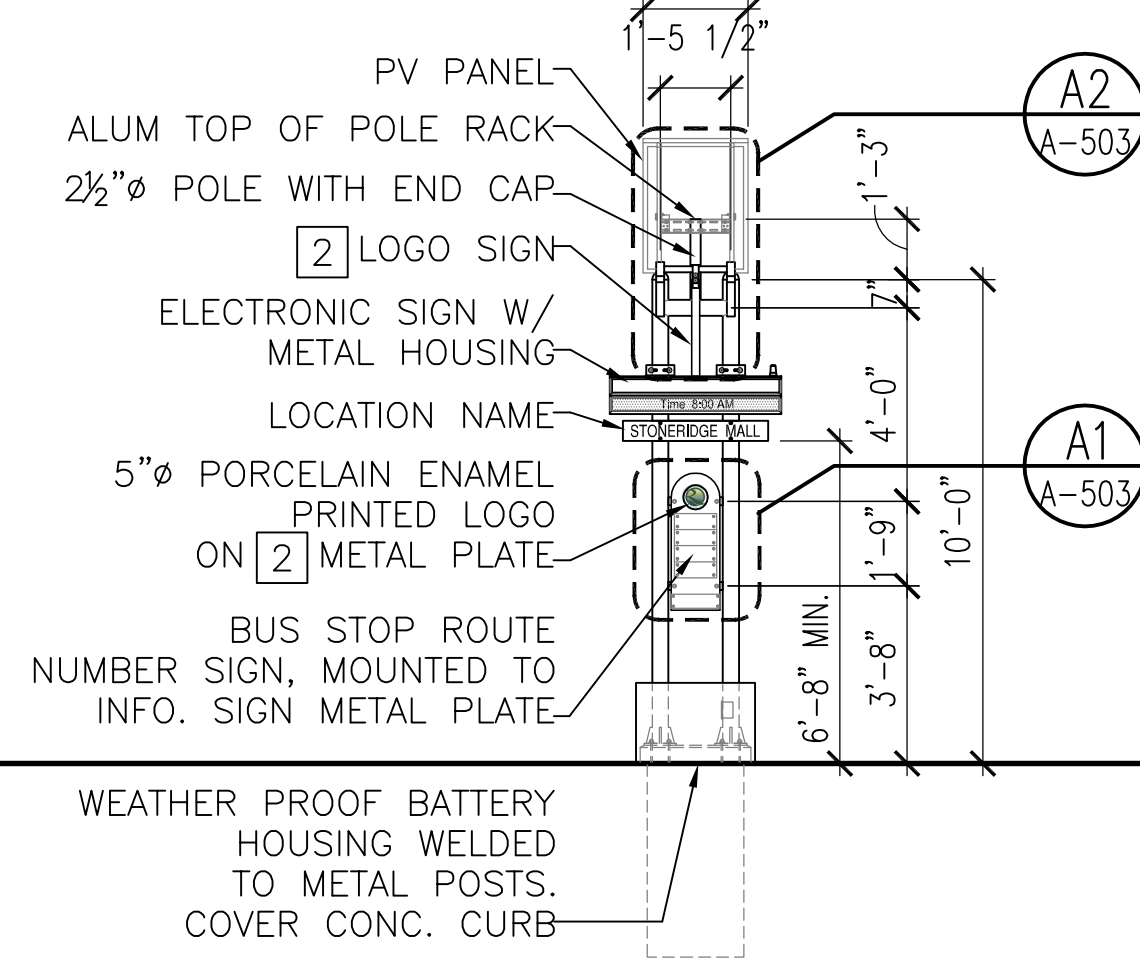

B2 FRONT ELEVATION W/ PV
 A-111 SCALE: 1/4"=1'-0"

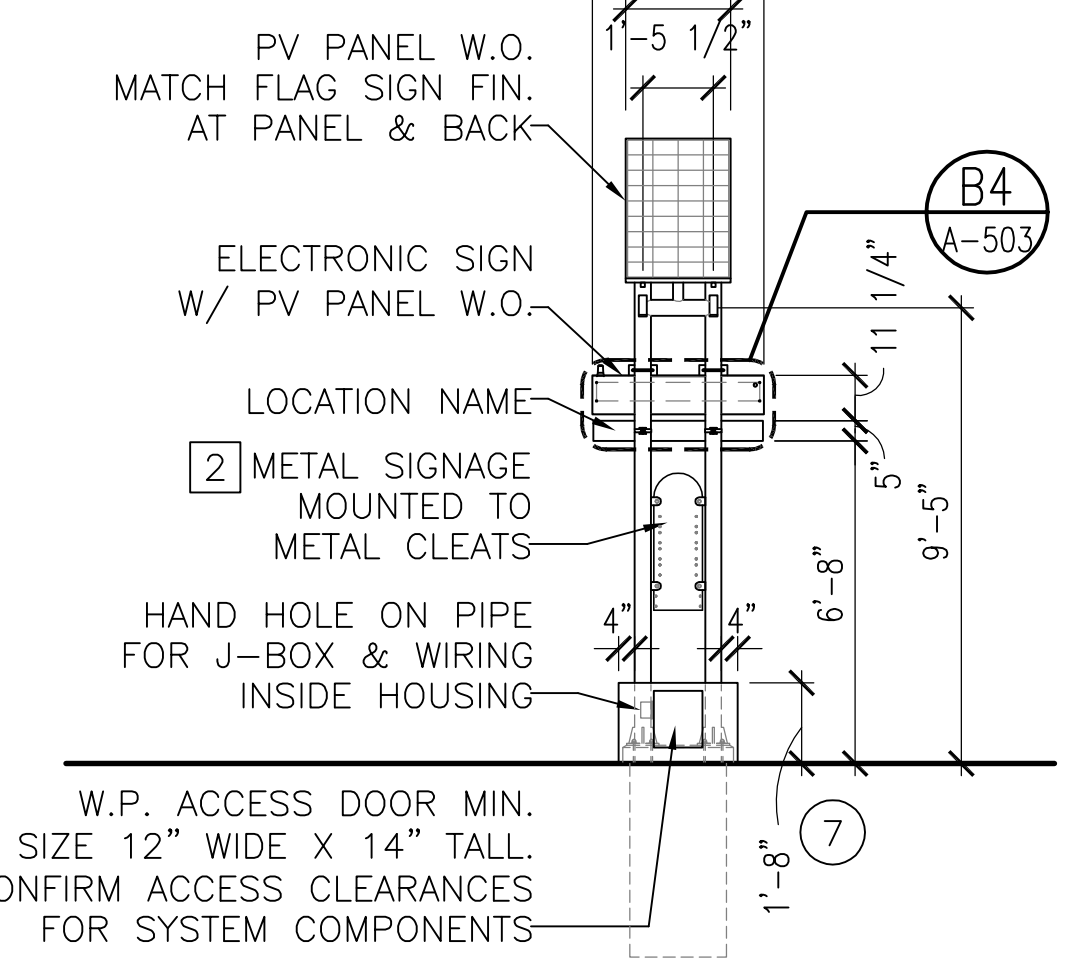

B3 REAR ELEVATION W/ PV
 A-111 SCALE: 1/4"=1'-0"

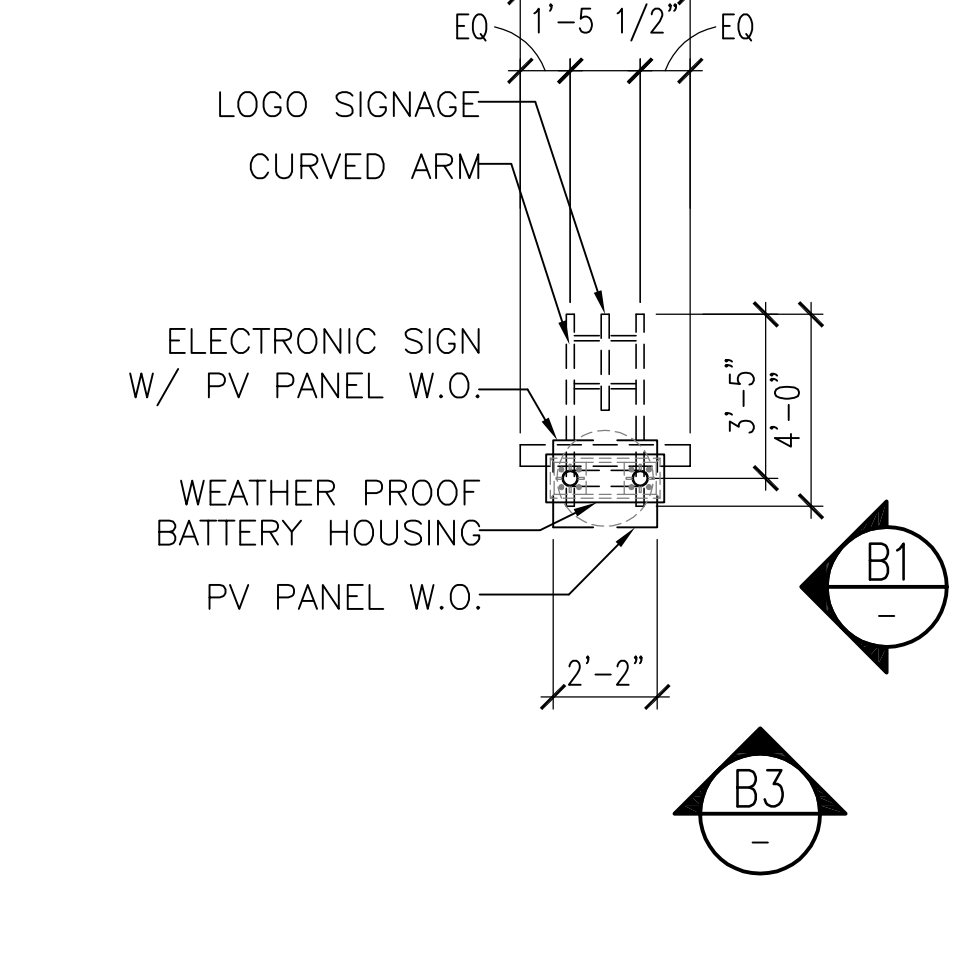

B4 PLAN W/ PV
 A-111 SCALE: 1/4"=1'-0"

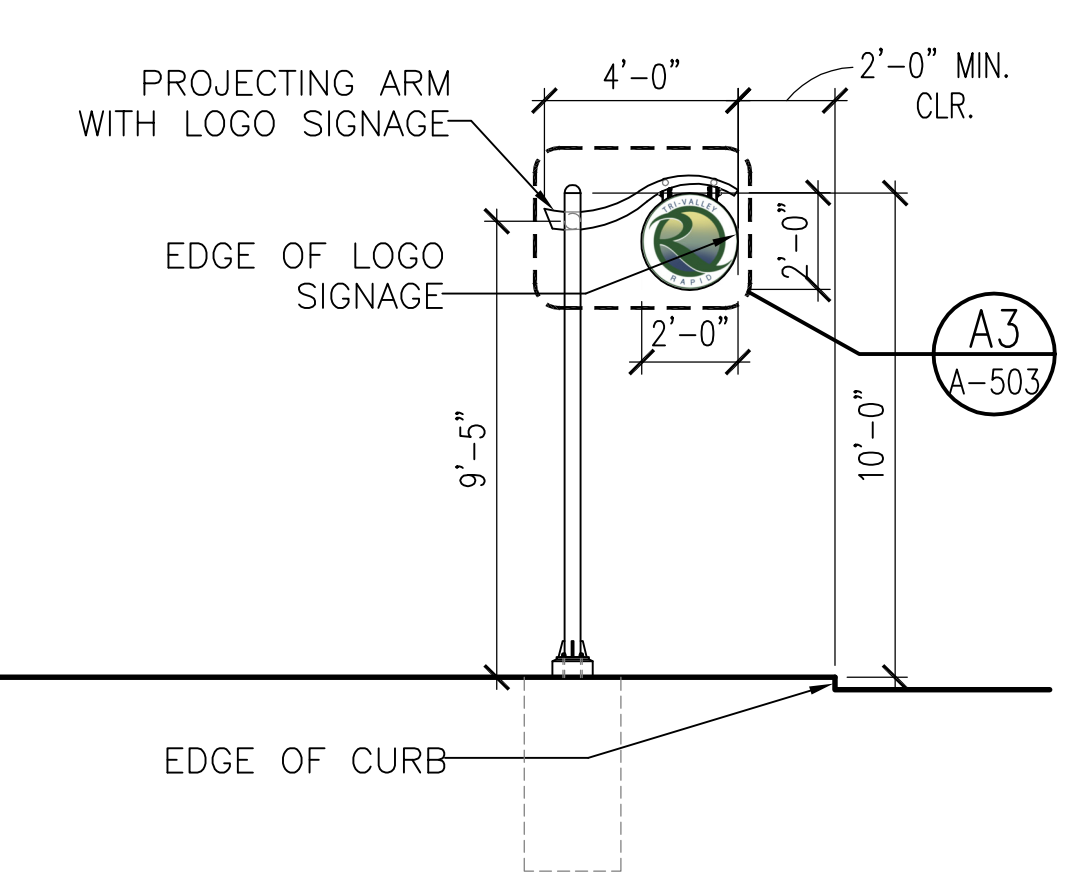

A1 TYP. SIDE ELEVATION
 A-111 SCALE: 1/4"=1'-0"

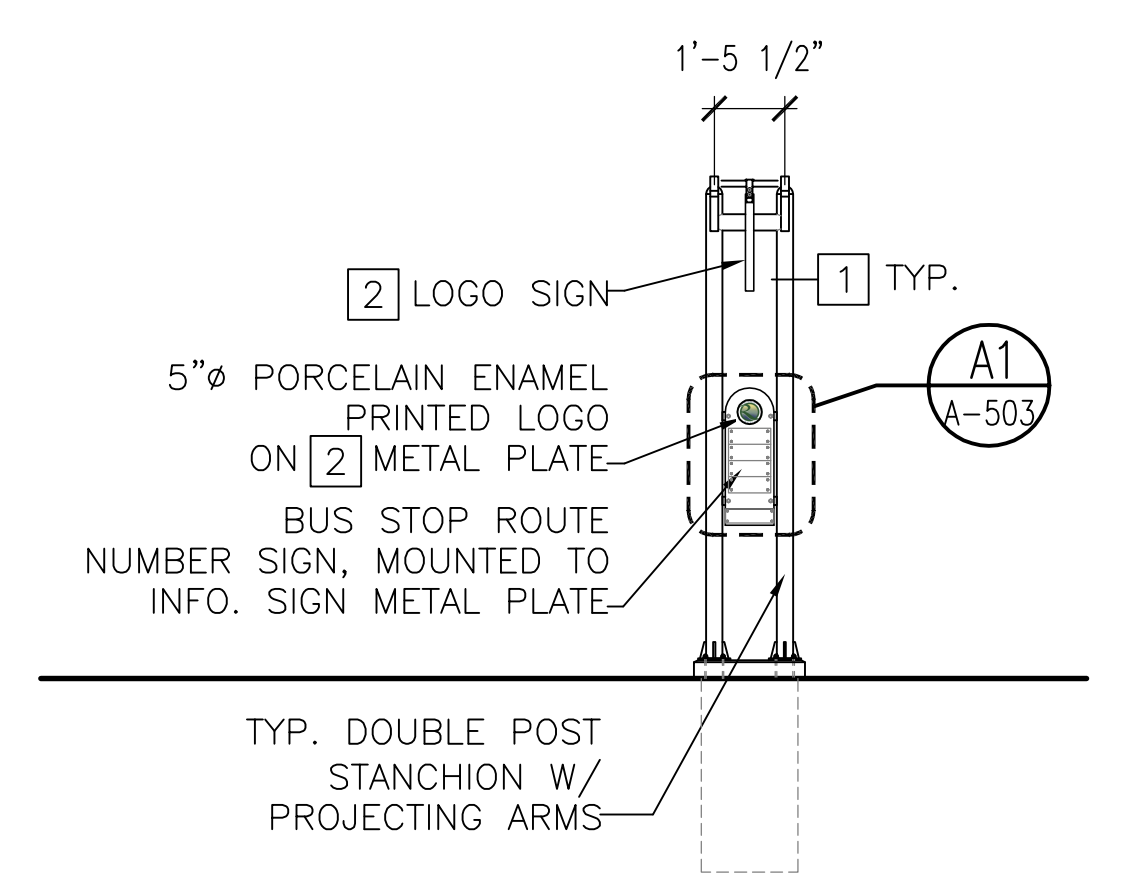

A2 TYP. FRONT ELEVATION
 A-111 SCALE: 1/4"=1'-0"

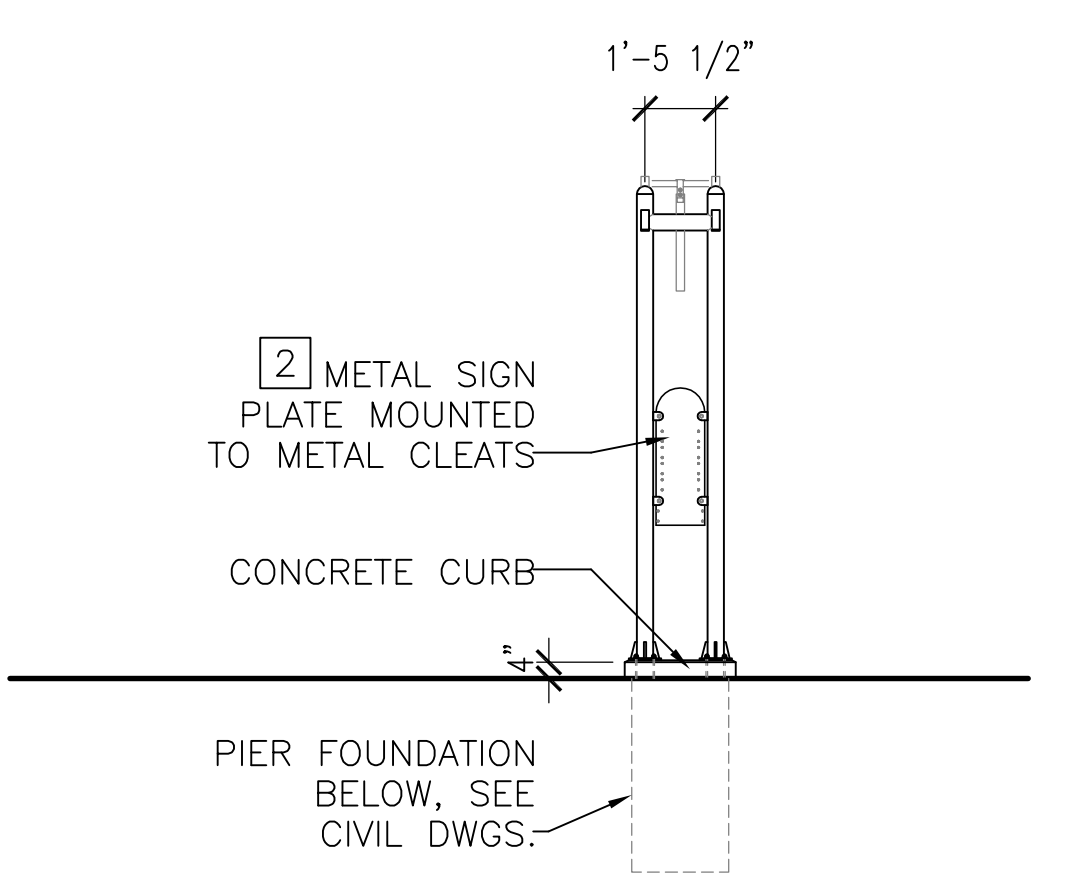

A3 TYP. REAR ELEVATION
 A-111 SCALE: 1/4"=1'-0"

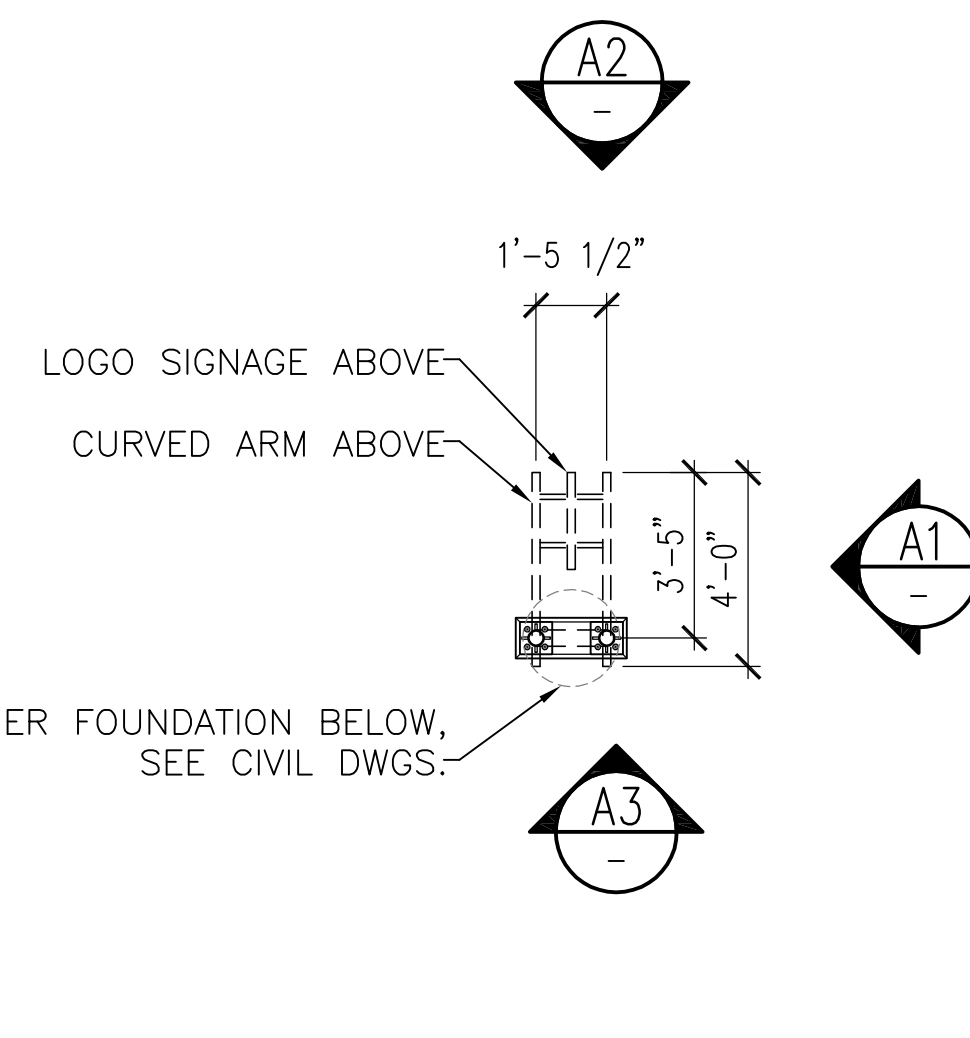

A4 TYP. PLAN
 A-111 SCALE: 1/4"=1'-0"

FILE INFO: F:\07002-LAVTA-R1e10-BRT\000ADD\A112.dwg XREFS:XTBLK; XFPL-BASIC; XGRID-BASIC; XRCPL-BASIC; XRFPL-BASIC; XTBLK-Phase 1; XTBLK-Procurement PLOTTED: May 07, 2009 11:13am By:bernard

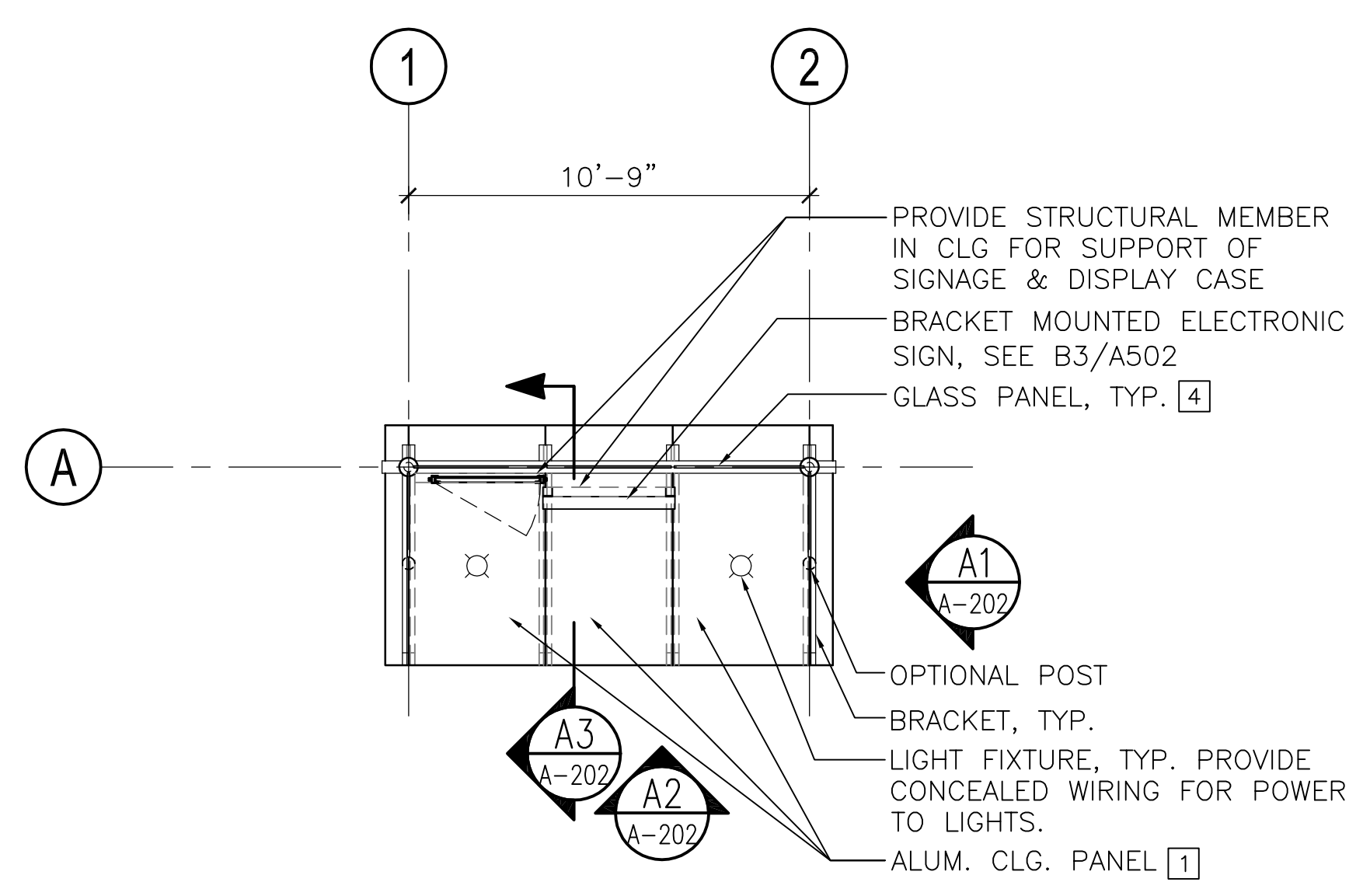

B1 REFLECTED CEILING PLAN
A-112 SCALE: 1/4"=1'-0"

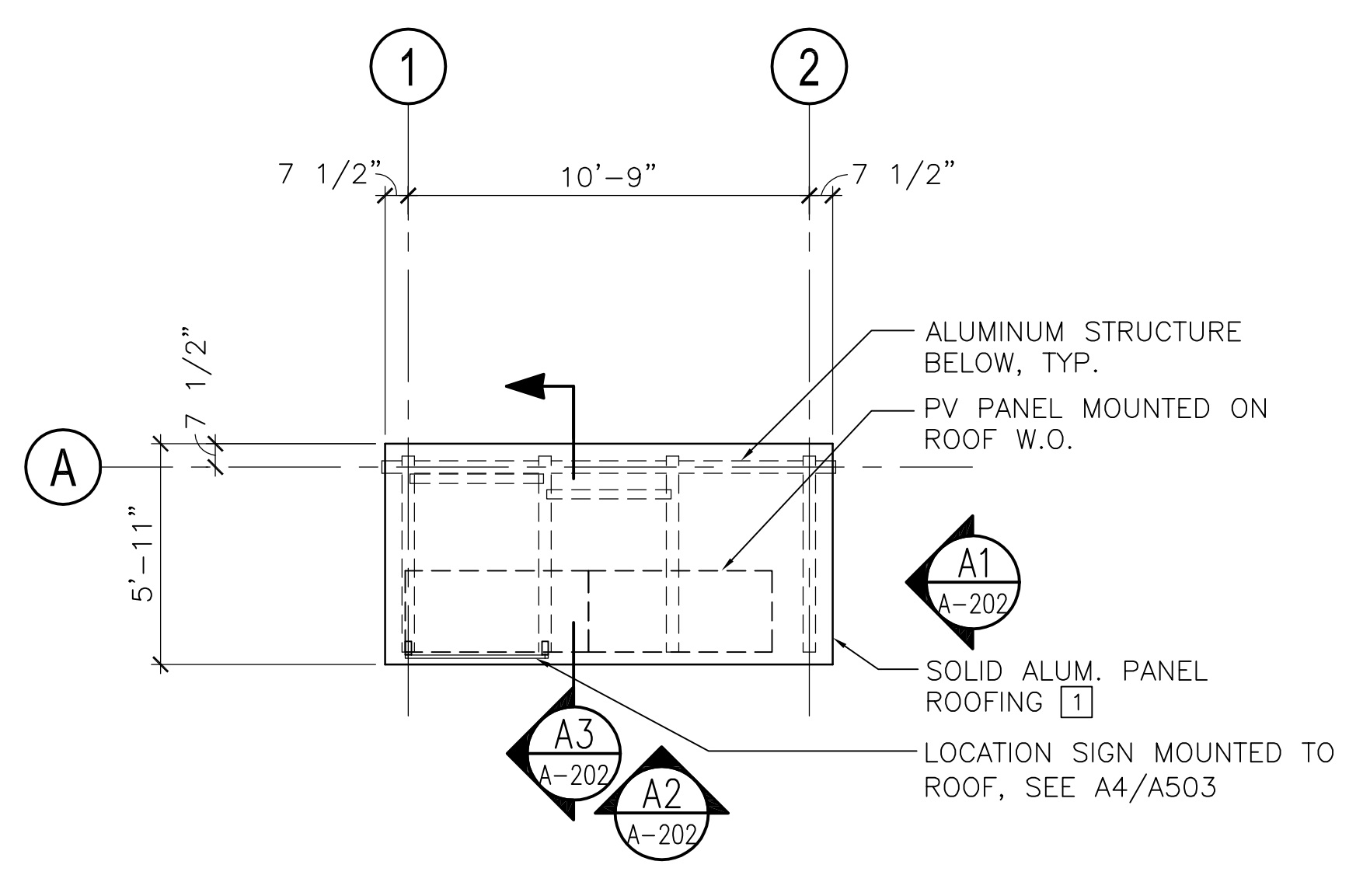

B2 ROOF PLAN
A-112 SCALE: 1/4"=1'-0"

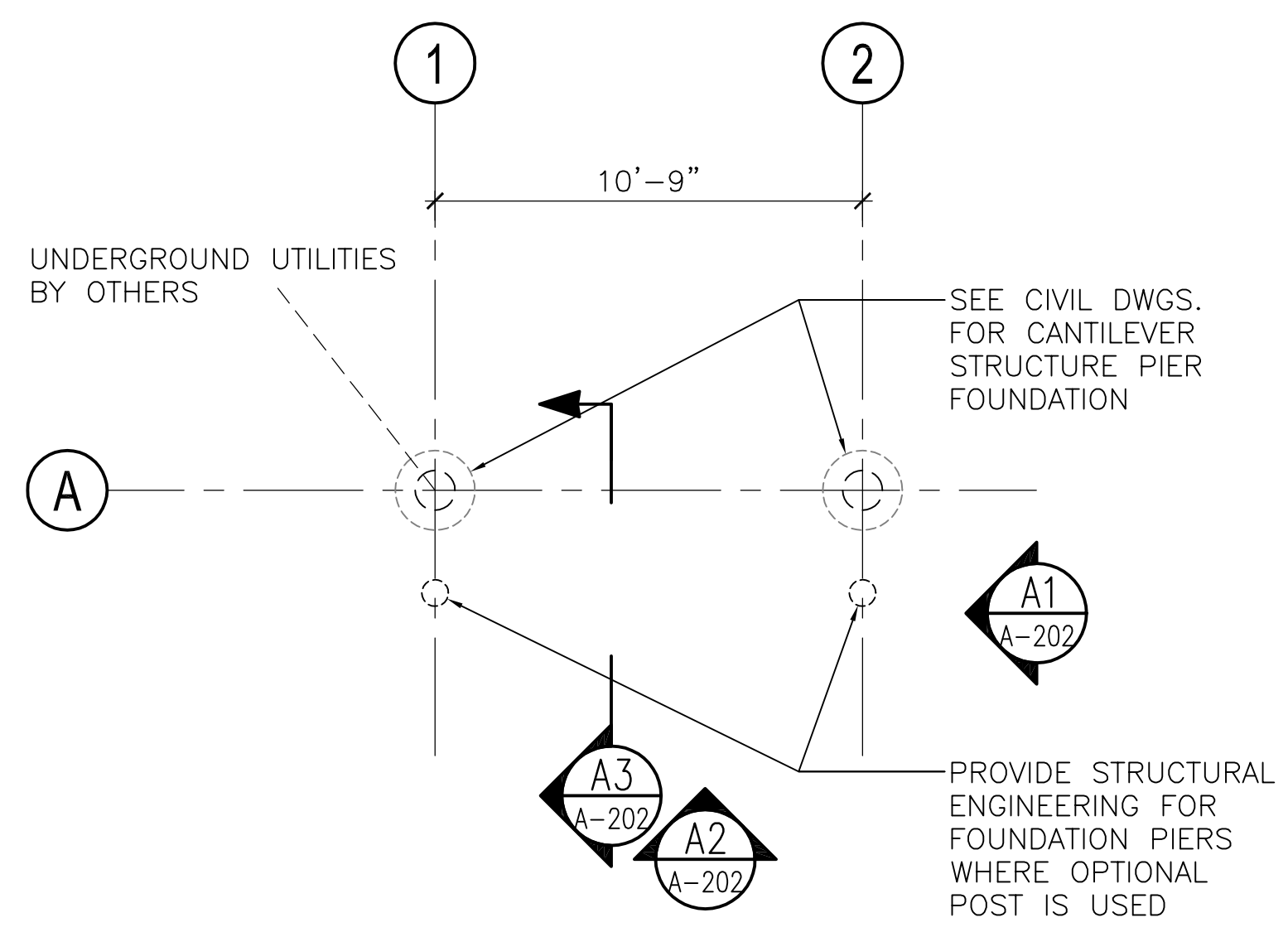

A1 FOUNDATION PLAN
A-112 SCALE: 1/4"=1'-0"

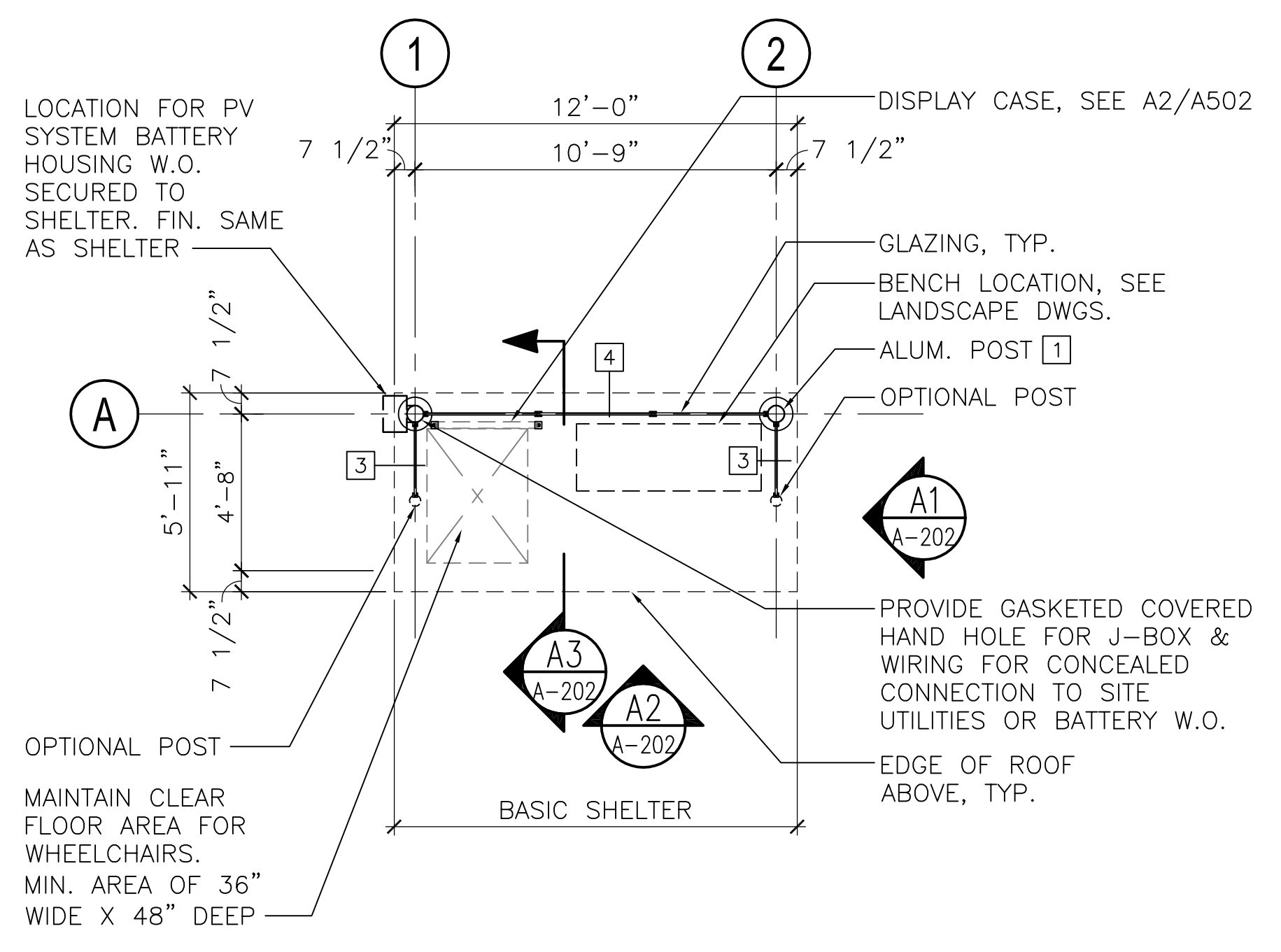

A2 FLOOR PLAN
A-112 SCALE: 1/4"=1'-0"

SHEET NOTES

1. PROVIDE MODULAR PRE-ENGINEERED SHELTER FOR RAPID-BASIC BUS STOPS. SEE SHEET A202 FOR ELEVATIONS.
2. SEE CIVIL DRAWINGS FOR PLACEMENT OF SHELTERS ON SITES. INSTALLATION BY OTHERS.
3. SEE LANDSCAPE DRAWINGS FOR SITE BENCHES & AMENITIES.
4. PROVIDE ACCESS HAND HOLE FOR CONNECTING SHELTER TO SITE UTILITY POWER. PROVIDE WIRING FOR LIGHTING & ELECTRONIC SIGN CONCEALED IN STRUCTURE.
5. SEE SIGNAGE SCHEDULE ON A601 FOR LOCATIONS W/ PV POWER FOR ELECTRONIC SIGN & LIGHTS. PROVIDE PHOTO VOLTAIC PANELS, BATTERY & HOUSING WHERE PV POWER IS REQUIRED. PROVIDE WIRING CONCEALED IN STRUCTURE FOR PV SYSTEM, LIGHTS, & ELECTRONIC SIGN SYSTEM.
6. OWNER TO FURNISH TO FLAG SIGN FABRICATOR, THE REQUIRED DIMENSIONS OF BATTERY & CONTROL ENCLOSURE PRIOR TO FABRICATION.

KEY NOTES

1. CONCRETE FOUNDATION BY OTHERS, SEE CIVIL DWGS.
2. PROVIDE TEMPLATES FOR ALL INSERT PLACEMENT FOR SHELTER PER MANUFACTURER.

FINISH

- 1 METALLIC SILVER COATING
- 2 NOT USED
- 3 LAMINATED TEMPERED GLASS W/ RAPID LOGO IMAGE (SIGN TYPE 5)
- 4 1/2" TEMPERED GLASS W/ BAKED ON TRANSLUCENT SILVER WARNING BAND @ 3' ABOVE GRADE

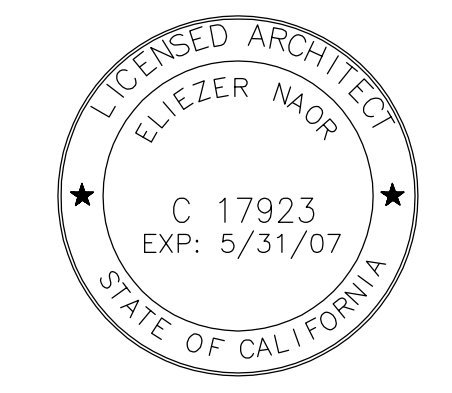

MAY 8, 2009

ISSUES/REVISIONS		
NO.	DATE	DESCRIPTION

RAPID BUS STOP IMPROVEMENTS PROCUREMENT

DESIGNED BY: VL/PN/BNL	CHECKED BY: JA	APPROVED BY:
PROJECT NUMBER: SCALE: 1/4" = 1'-0"		097447005

PLANS - RAPID BASIC SHELTER

FILE INFO: F:\07002-LAVA-R1e10-BRT\000ADD\A113.dwg XREFS:XTBLK; XGRID-STANDARD; XFPL-STANDARD; XGRID-STANDARD; XRCPL-STANDARD; XRFPL-STANDARD; XTBLK-Phase 1; XFNPL-STANDARD; XTBLK-STANDARD; XTBLK-Procurement PLOTTED: May 07, 2009 11:14am B'ibbernard

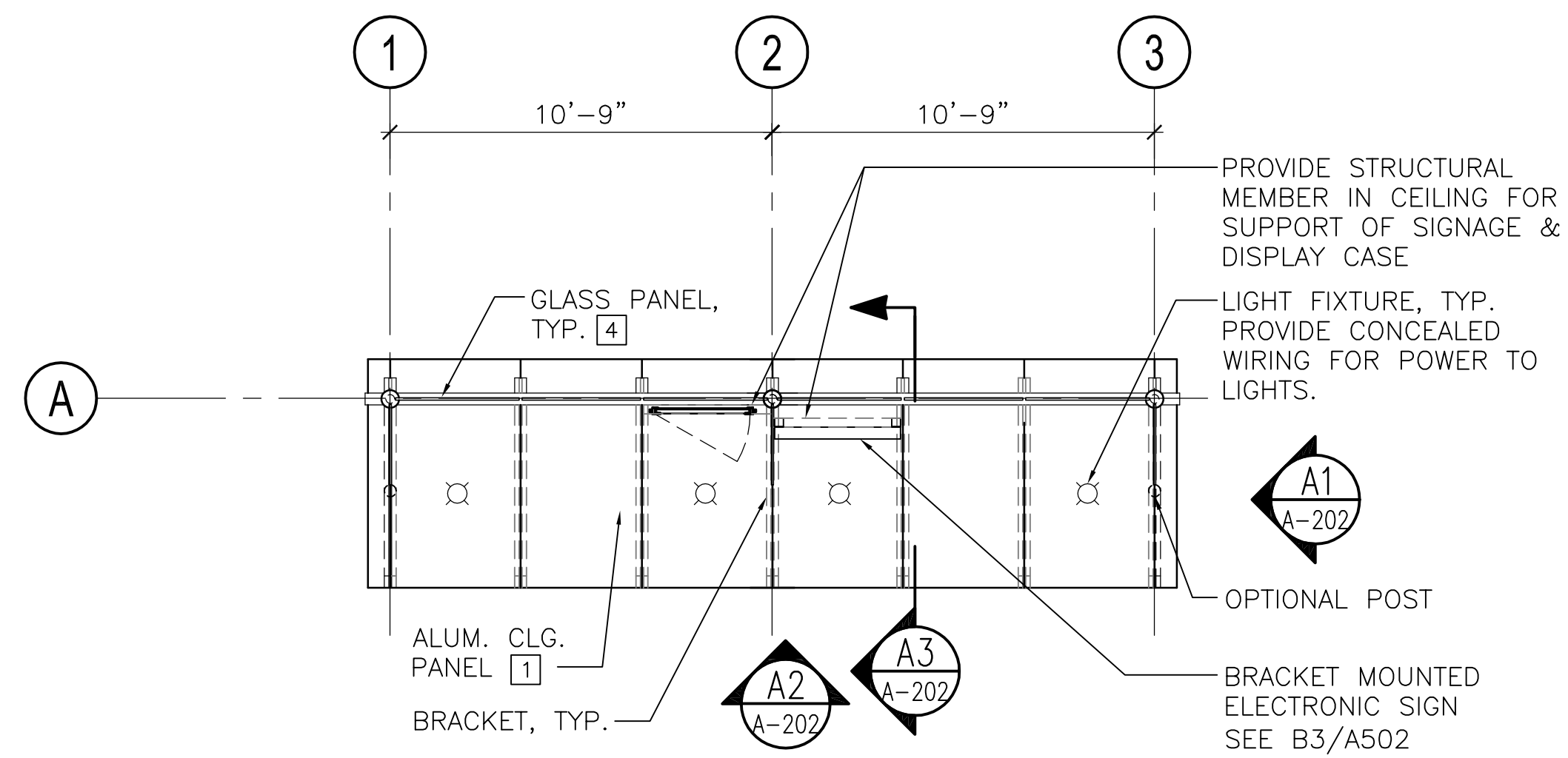

B1 REFLECTED CEILING PLAN
A-113 SCALE: 1/4"=1'-0"

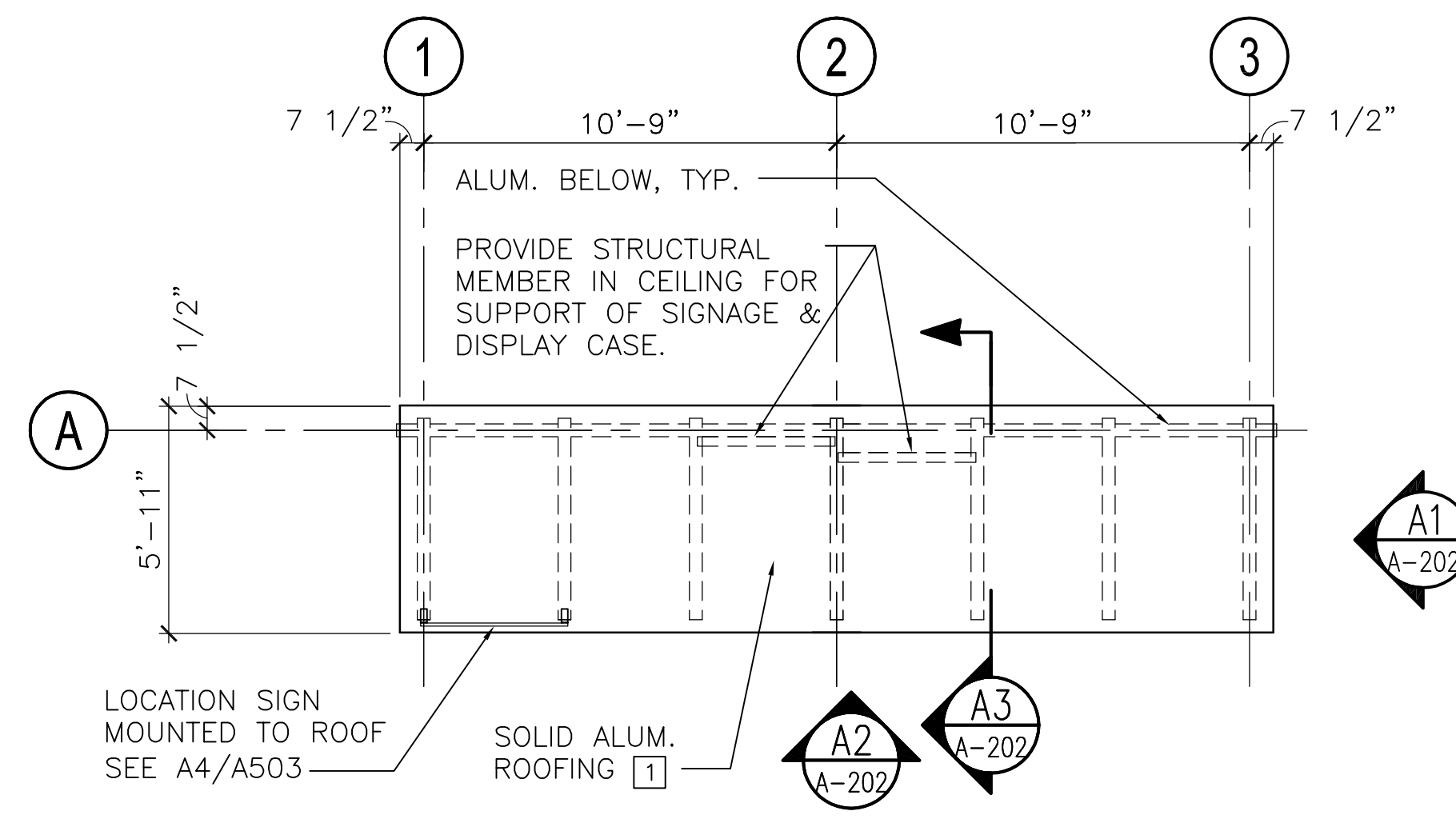

B2 ROOF PLAN
A-113 SCALE: 1/4"=1'-0"

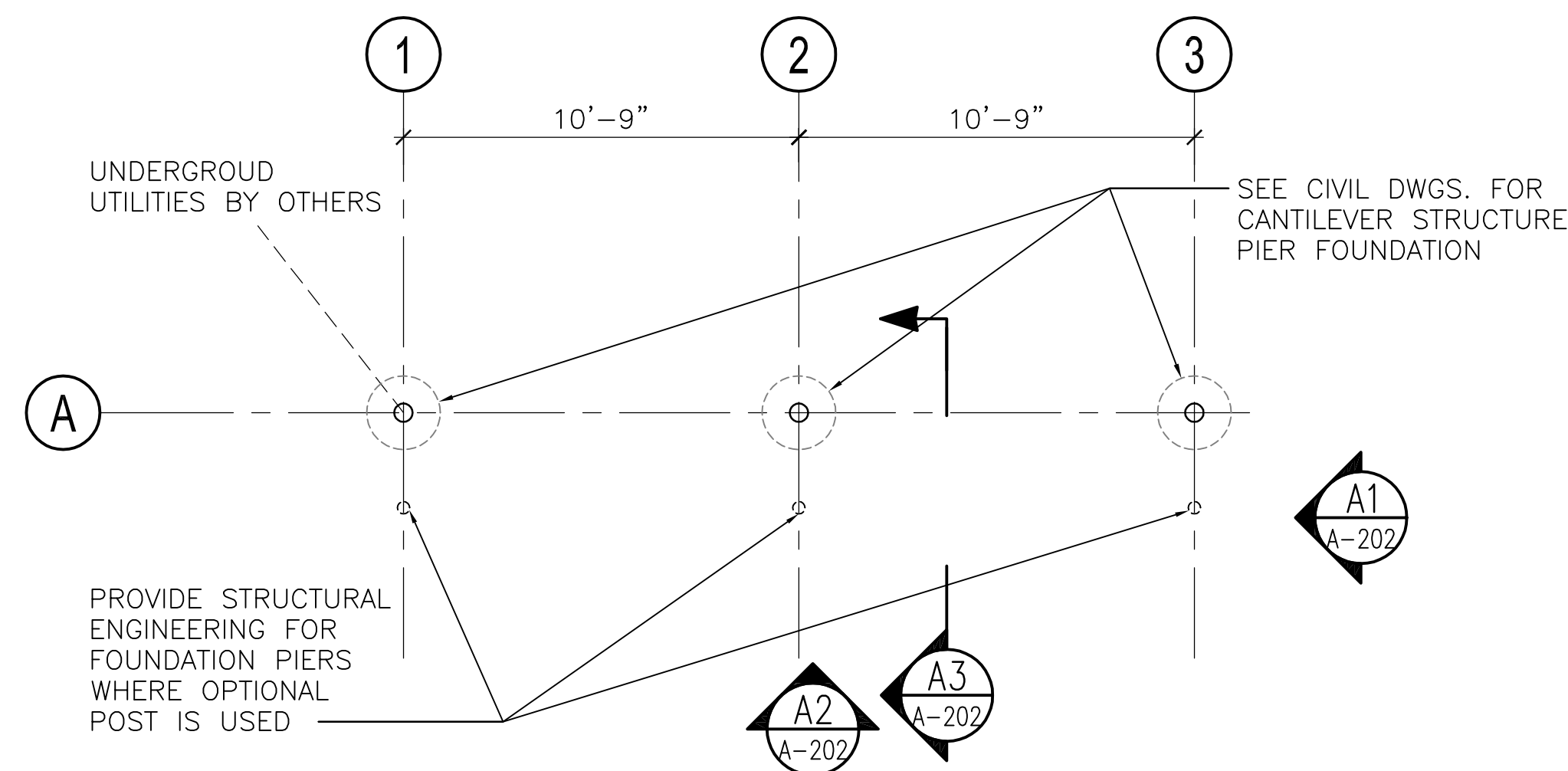

A1 FOUNDATION PLAN
A-113 SCALE: 1/4"=1'-0"

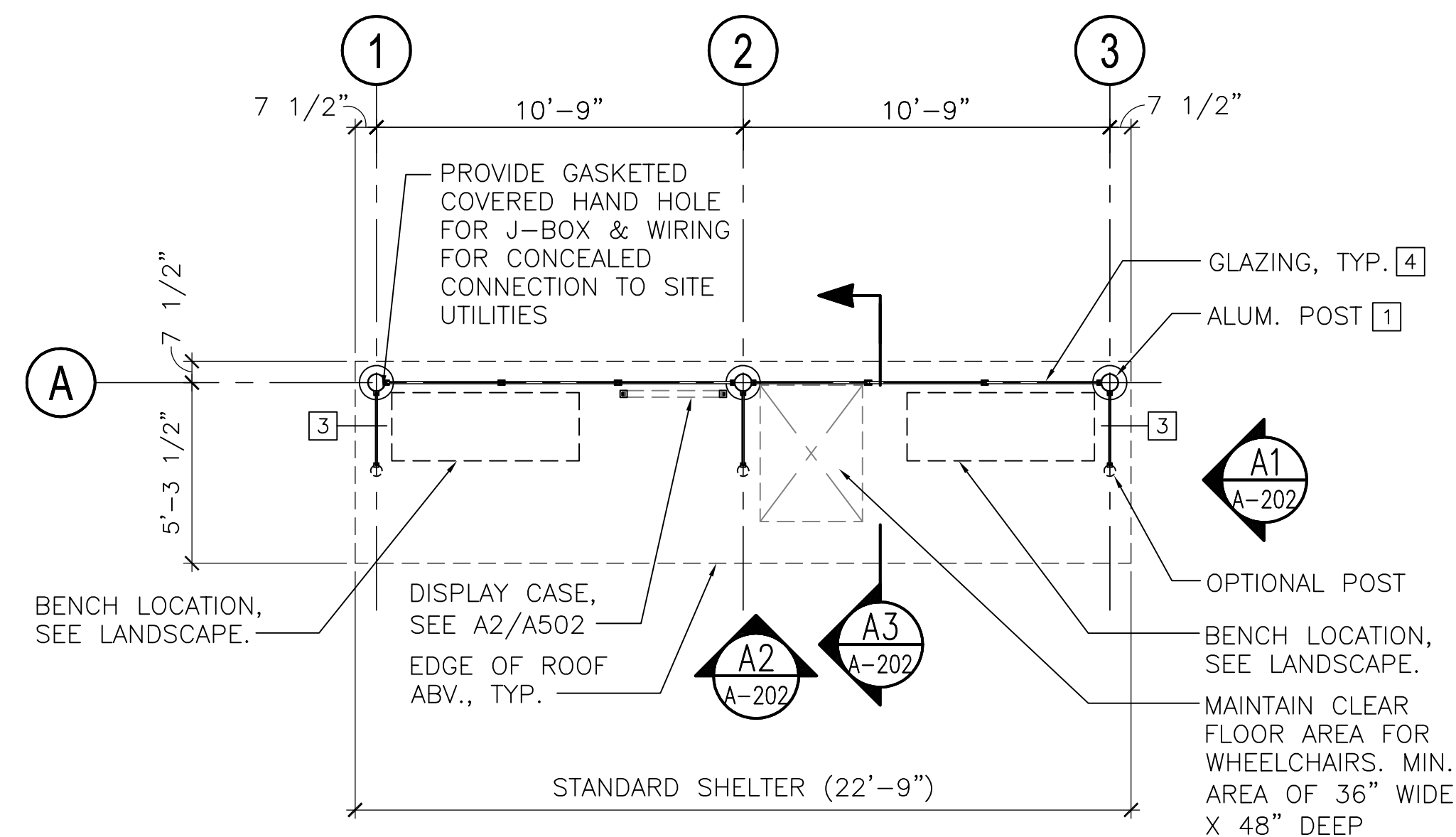

A2 FLOOR PLAN
A-113 SCALE: 1/4"=1'-0"

SHEET NOTES

1. PROVIDE MODULAR PRE-ENGINEERED SHELTER FOR RAPID-STANDARD BUS STOPS. SEE SHEET A202 FOR ELEVATIONS.
2. SEE CIVIL DRAWINGS FOR PLACEMENT OF SHELTERS ON SITES. INSTALLATION BY OTHERS
3. SEE LANDSCAPE DRAWINGS FOR SITE BENCHES & AMENITIES.
4. PROVIDE ACCESS HAND HOLE FOR CONNECTING SHELTER TO SITE UTILITY POWER. PROVIDE WIRING FOR LIGHTING & ELECTRONIC SIGN CONCEALED IN STRUCTURE.

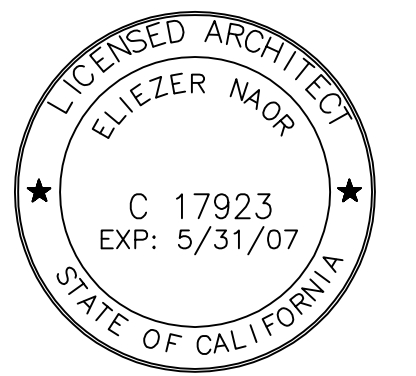

MAY 8, 2009

KEY NOTES

1. CONCRETE FOUNDATION ENGINEERED BY MANUFACTURER IF OPTIONAL POST IS USED.
2. PROVIDE TEMPLATES FOR ALL INSERT PLACEMENT FOR SHELTER PER MANUFACTURER.

ISSUES/REVISIONS

NO.	DATE	DESCRIPTION

FINISH

- [1] METALLIC SILVER COATING
- [2] NOT USED
- [3] LAMINATED TEMPERED GLASS W/ RAPID LOGO IMAGE (SIGN TYPE 5)
- [4] 1/2" TEMPERED GLASS W/ BAKED ON TRANSLUCENT SILVER WARNING BAND @ 3'

RAPID BUS STOP IMPROVEMENTS PROCUREMENT

DRAWN BY: VL/PN/BNL DESIGNED BY: CHECKED BY: JA APPROVED BY:
 PROJECT NUMBER: 097447005
 SCALE: 1/4" = 1'-0"

PLANS - RAPID STANDARD SHELTER

A-113

4 OF 13

E D C B A

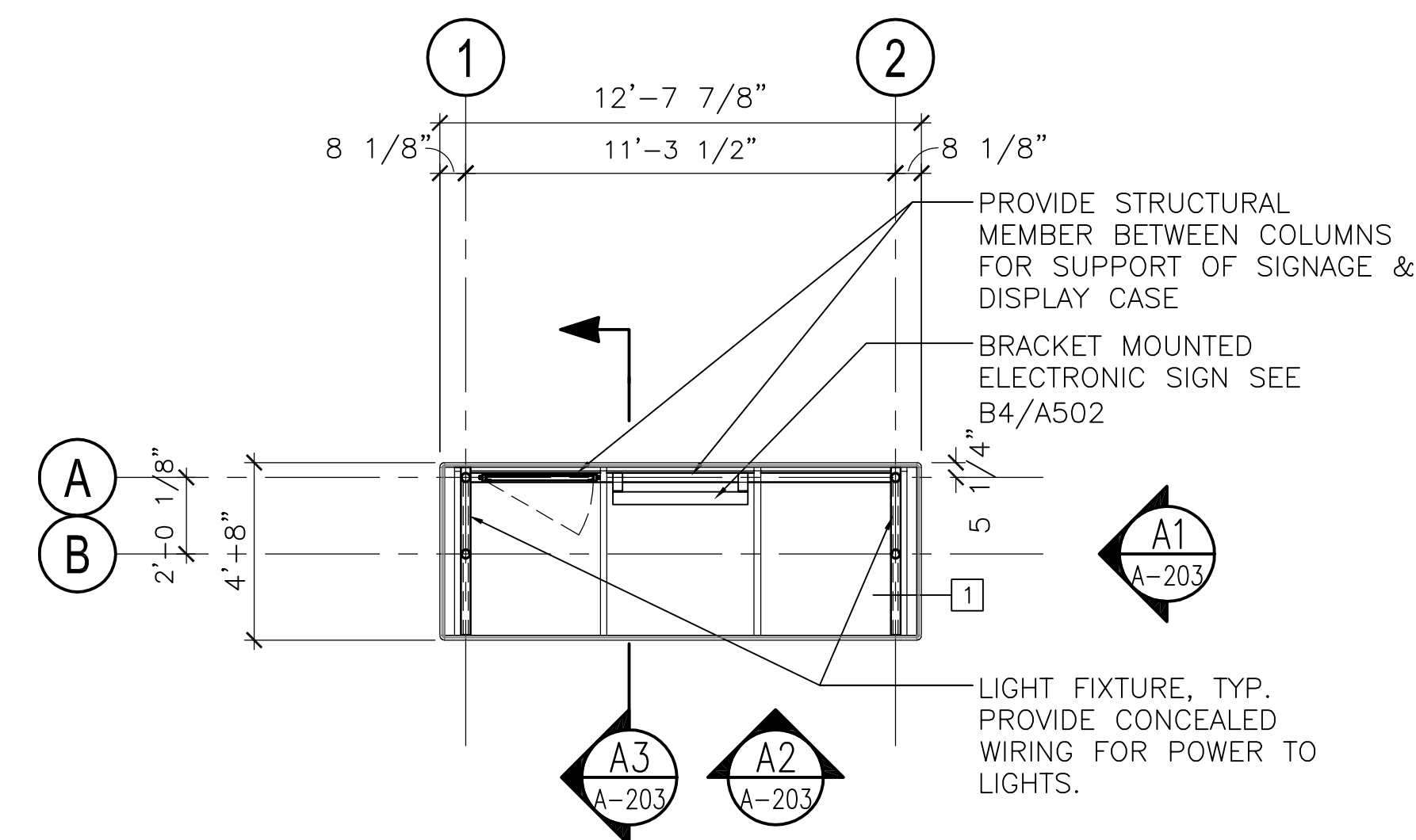

B1 REFLECTED CEILING PLAN
A-112 SCALE: 1/4"=1'-0"

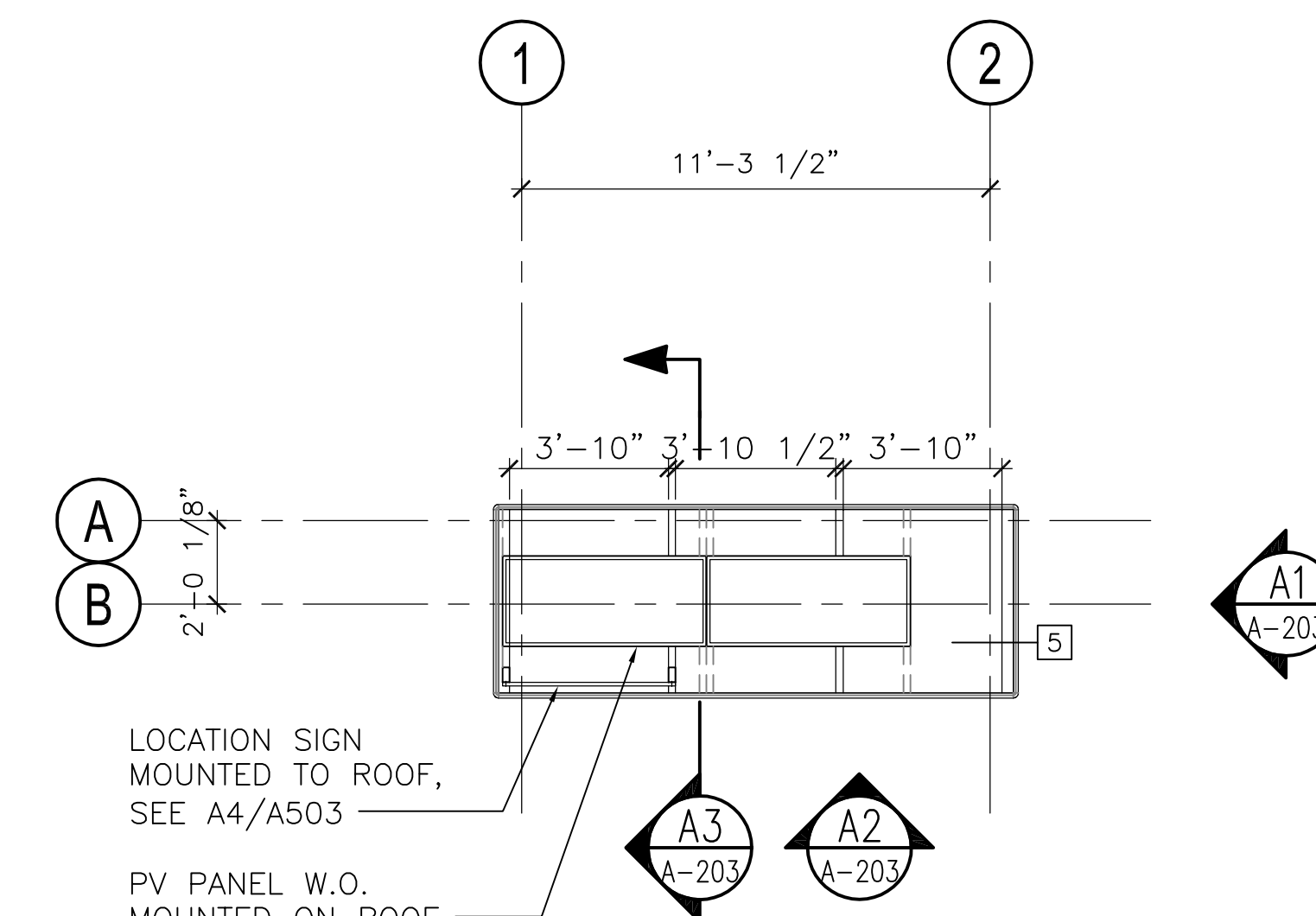

B2 ROOF PLAN
A-112 SCALE: 1/4"=1'-0"

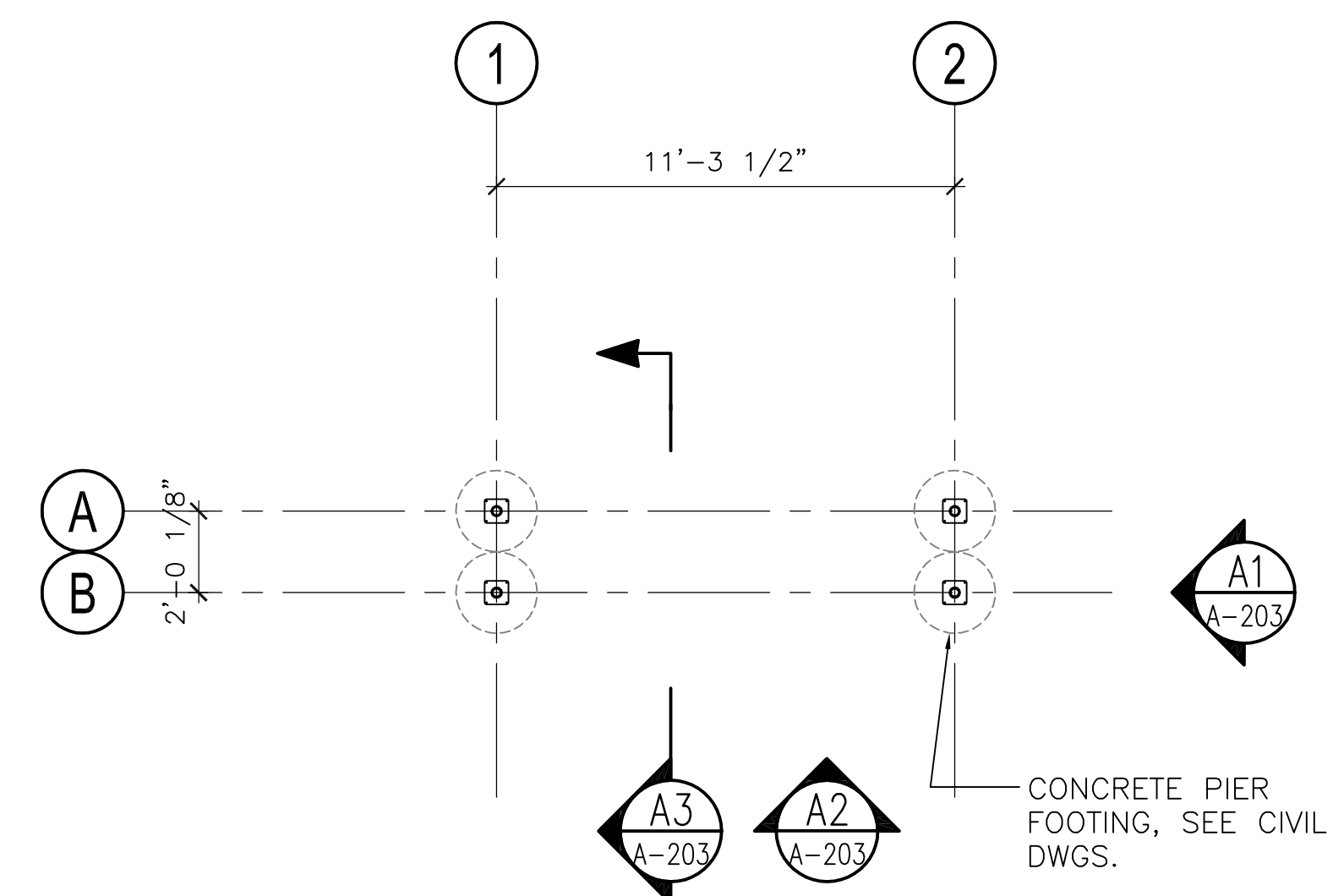

A1 FOUNDATION PLAN
A-112 SCALE: 1/4"=1'-0"

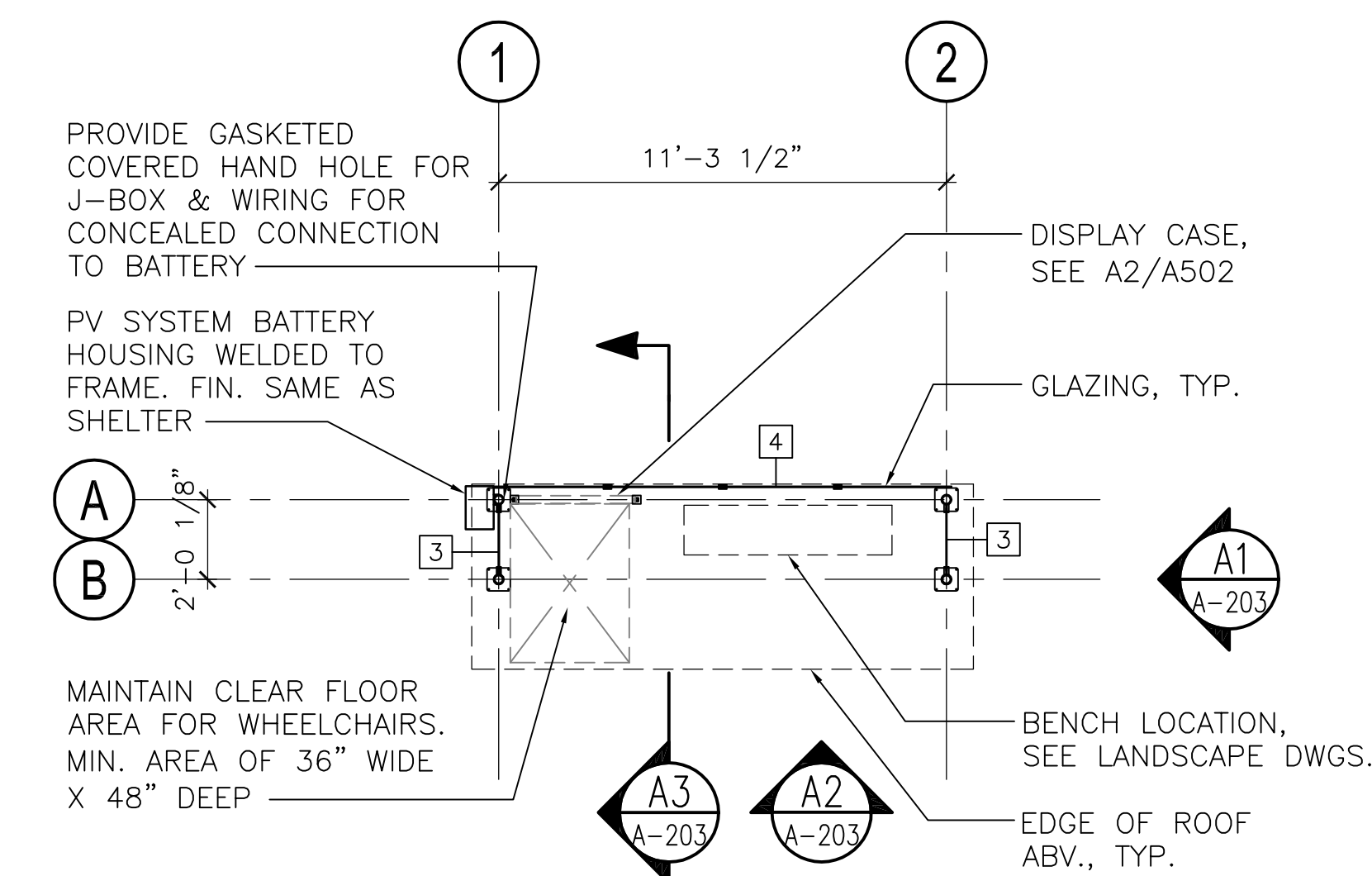

A2 FLOOR PLAN
A-112 SCALE: 1/4"=1'-0"

SHEET NOTES

1. PROVIDE MODULAR PRE-ENGINEERED SHELTER FOR DUBLIN-BASIC BUS STOPS. SEE SHEET A203 FOR ELEVATIONS.
2. SEE CIVIL DRAWINGS FOR PLACEMENT OF SHELTERS ON SITES. INSTALLATION BY OTHERS
3. SEE LANDSCAPE DRAWINGS FOR SITE BENCHES & AMENITIES.
4. NOT USED.
5. SEE SIGNAGE SCHEDULE ON A601 FOR LOCATIONS W/ PV POWER FOR ELECTRONIC SIGN & LIGHTS. PROVIDE PHOTO VOLTAIC PANELS, BATTERY & HOUSING WHERE PV POWER IS REQUIRED. PROVIDE WIRING CONCEALED IN STRUCTURE FOR PV SYSTEM, LIGHTS, & ELECTRONIC SIGN SYSTEM.
6. OWNER TO FURNISH TO FLAG SIGN FABRICATOR, THE REQUIRED DIMENSIONS OF BATTERY & CONTROL ENCLOSURE PRIOR TO FABRICATION.

KEY NOTES

1. CONCRETE FOUNDATION, SEE CIVIL ENGINEER
2. PROVIDE TEMPLATES FOR ALL INSERT PLACEMENT FOR SHELTER PER MANUFACTURER.

FINISH

- 1 METALLIC SILVER COATING
- 2 NOT USED
- 3 LAMINATED TEMPERED GLASS W/ RAPID LOGO IMAGE (SIGN TYPE 5)
- 4 3/8" TEMPERED GLASS W/ BAKED ON TRANSLUCENT SILVER WARNING BAND @ 3'
- 5 3/8" POLYCARBONATE TRANSLUCENT GLAZING, BRONZE TINT TO MATCH EXISTING SHELTER ON DUBLIN BLVD.

VBN BUILDING
560 14th St.
Oakland, CA
94612
Tel: (510) 763-1313
Fax: (510) 465-1586

LICENSED ARCHITECT
ELEAZER NAOR
C 17923
EXP: 5/31/07
STATE OF CALIFORNIA



MAY 8, 2009

ISSUES/REVISIONS		
NO.	DATE	DESCRIPTION

RAPID BUS STOP IMPROVEMENTS PROCUREMENT

DESIGNED BY: VL/PN/BNL	CHECKED BY: JA	APPROVED BY:
PROJECT NUMBER: SCALE: 1/4" = 1'-0"		097447005

PLANS DUBLIN BASIC SHELTER

FILE INFO: F:\07002-LAVA-Rie-D-BRT\000ADD\A114.dwg XREFS:XTBLK; XGRID-DUBLIN; XTBLK-Procurement PLOTTED: May 07, 2009 11:19am BY:bernard

FILE INFO: F:\07002-LAVA-R1e10-BRT\000ADD\A115.dwg XREFS:XTBLK; XGRID-DUBLIN-STANDARD; XTBLK-Procurement PLOTTED: May 07, 2009 11:20am Btbernard

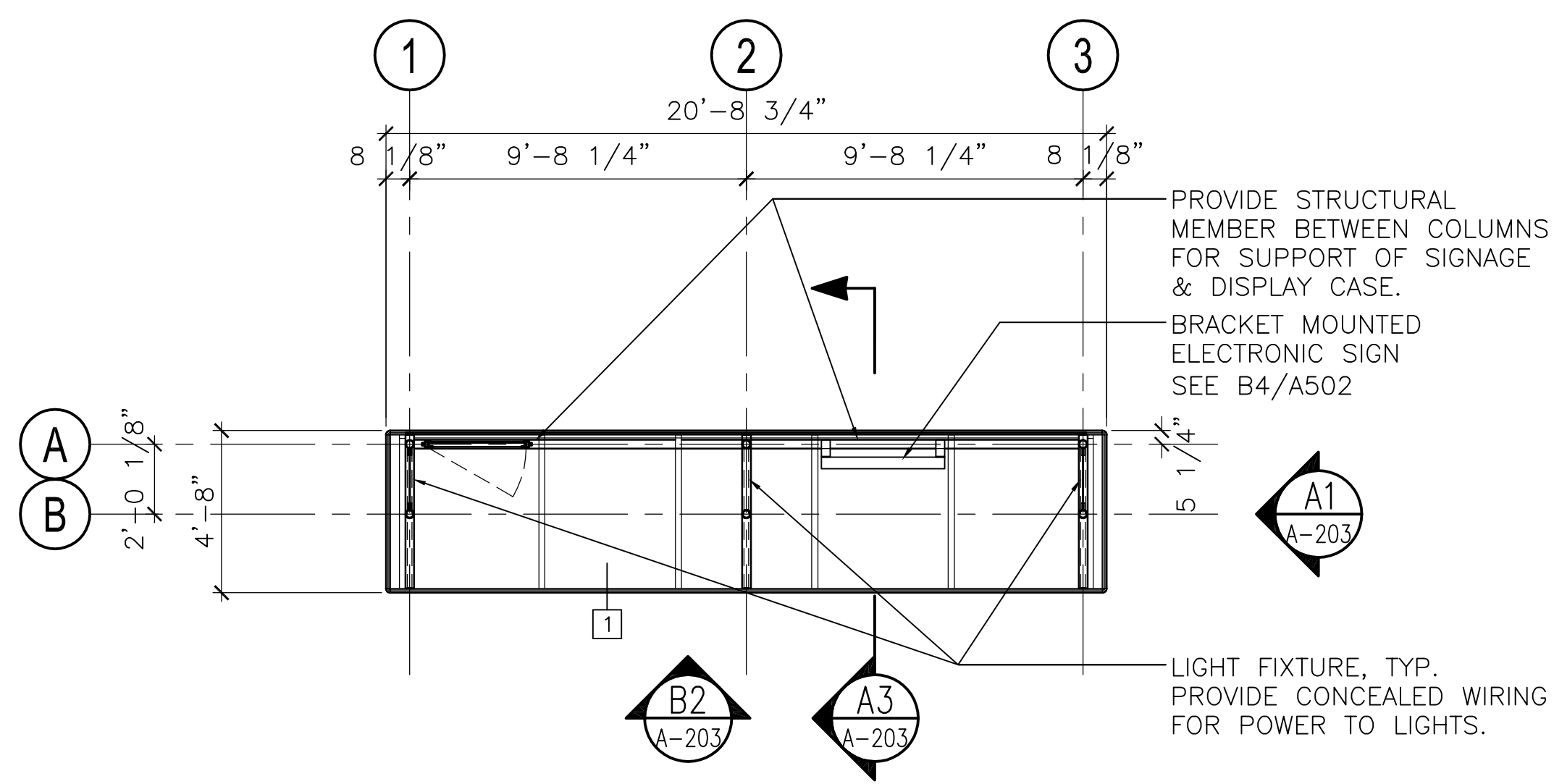

B1 REFLECTED CEILING PLAN
A-112 SCALE: 1/4"=1'-0"

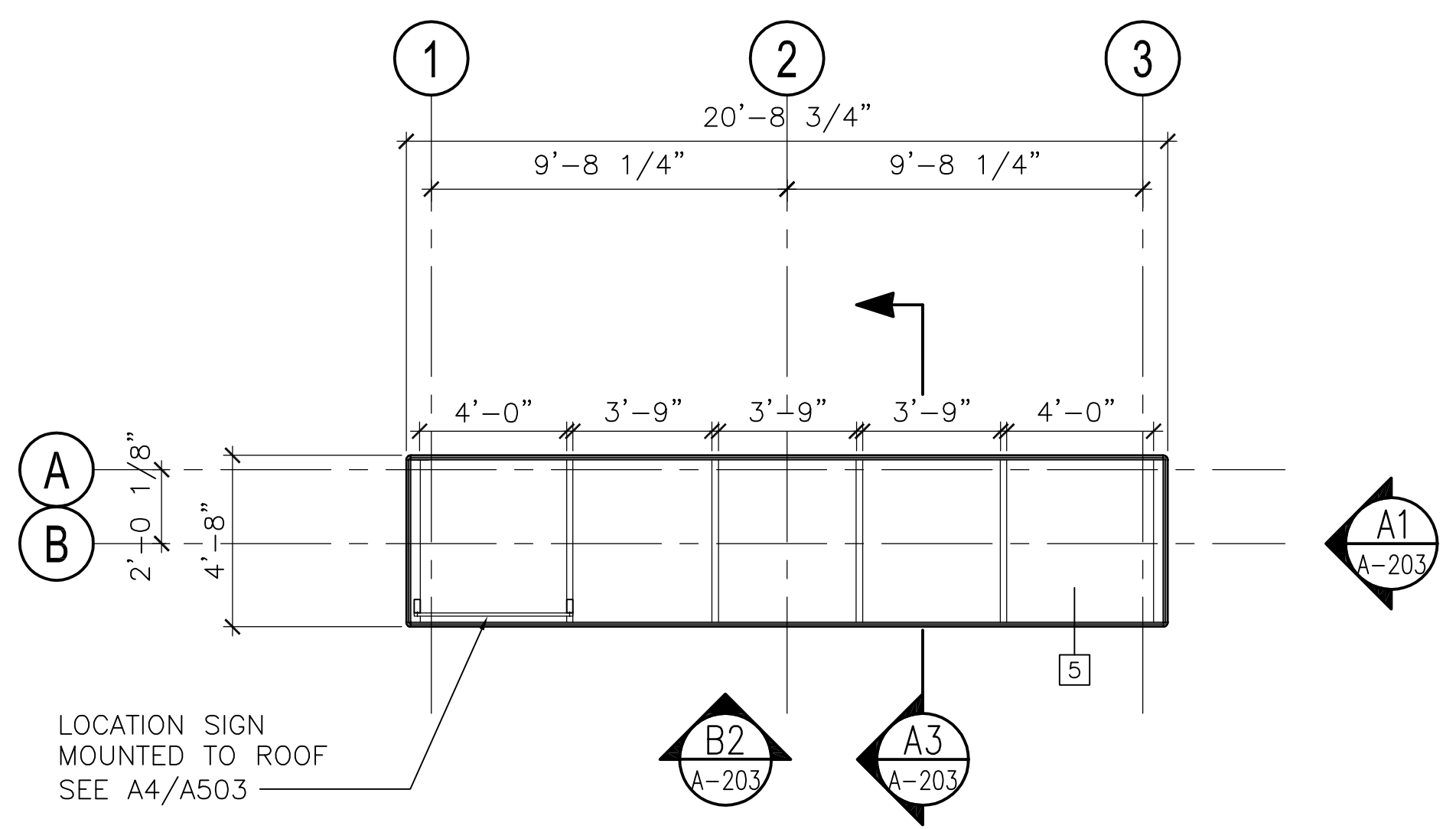

B2 ROOF PLAN
A-112 SCALE: 1/4"=1'-0"

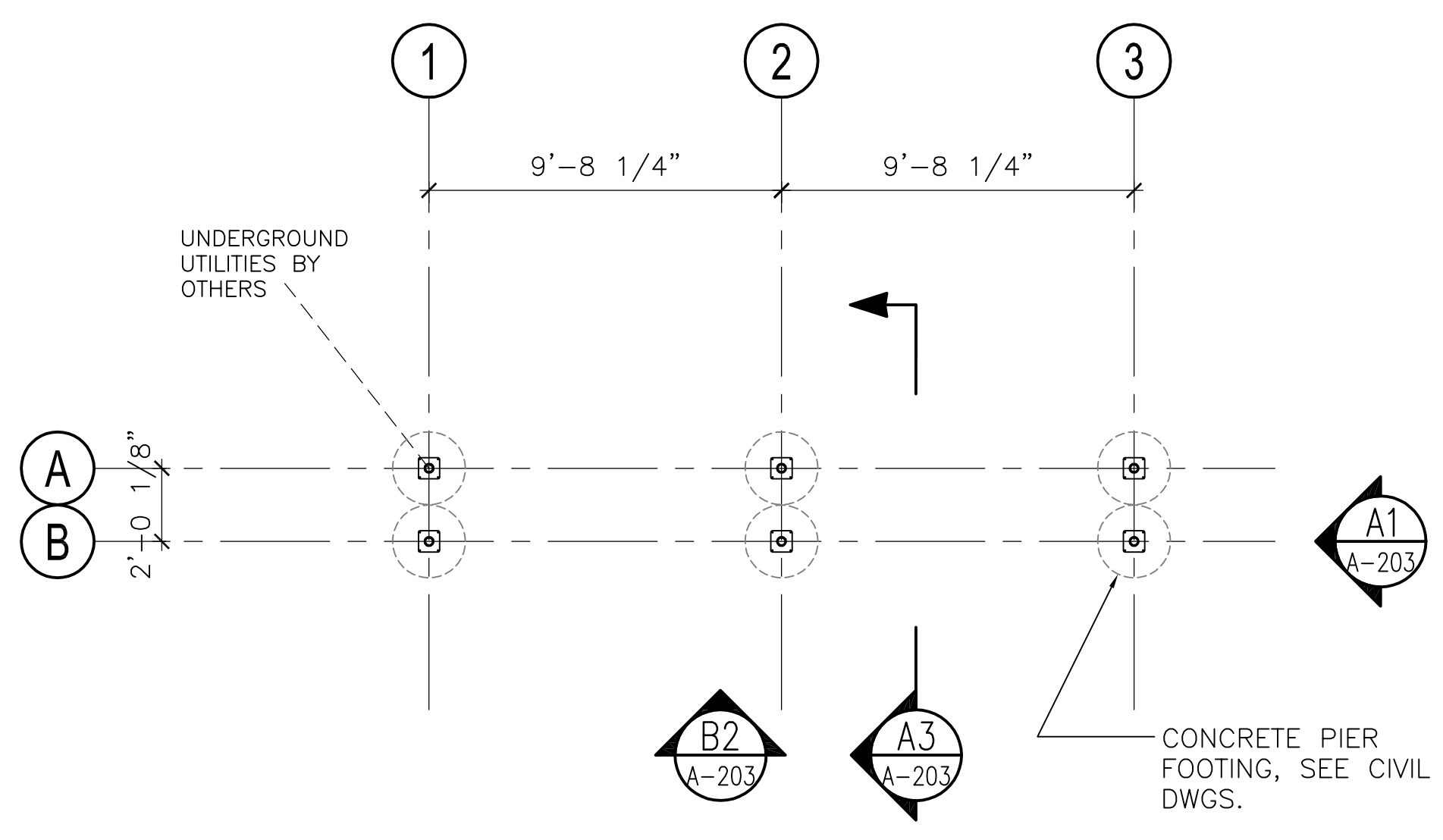

A1 FOUNDATION PLAN
A-112 SCALE: 1/4"=1'-0"

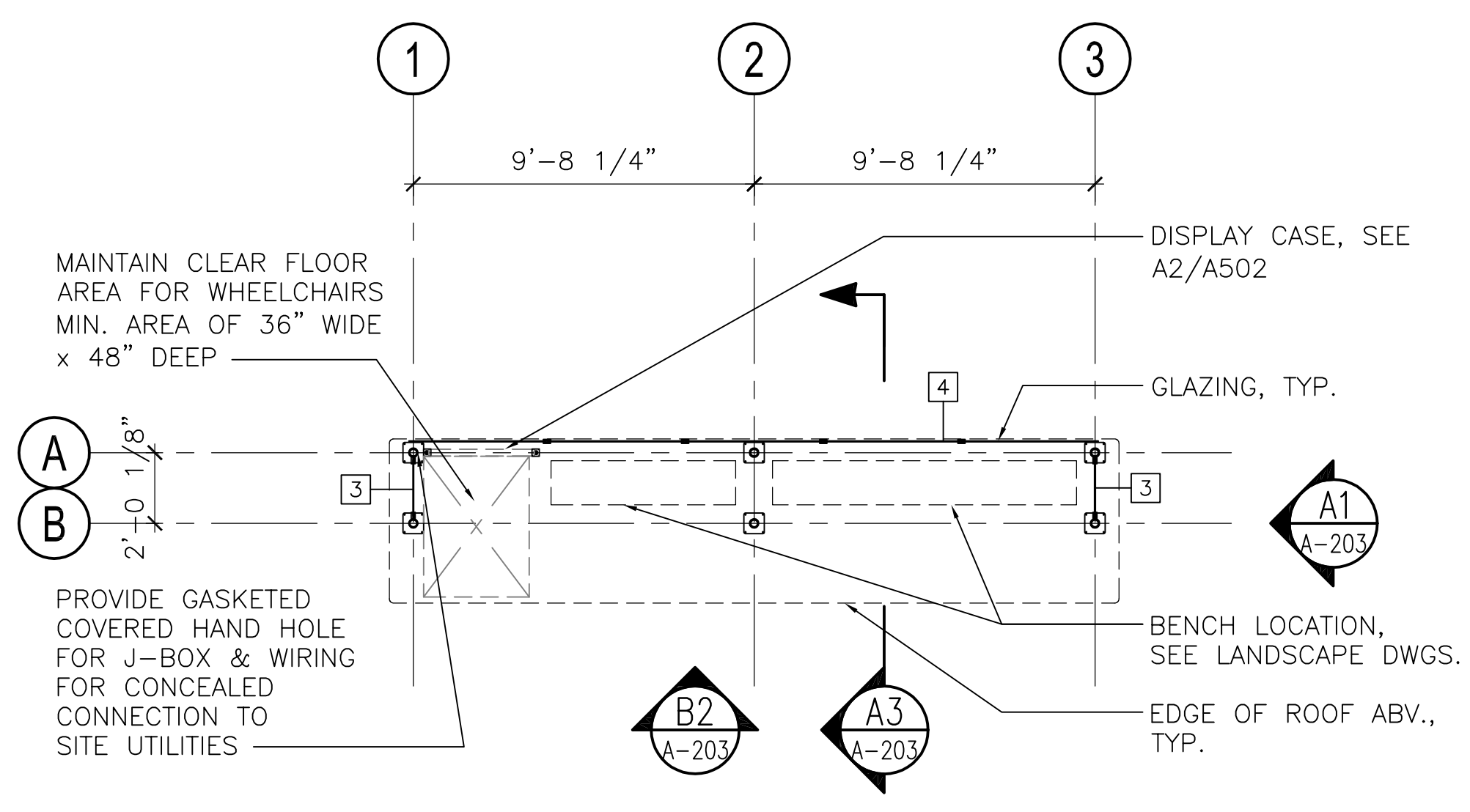

A2 FLOOR PLAN
A-112 SCALE: 1/4"=1'-0"

SHEET NOTES

1. PROVIDE MODULAR PRE-ENGINEERED SHELTER FOR DUBLIN-STANDARD BUS STOPS. SEE SHEET A203 FOR ELEVATIONS.
2. SEE CIVIL DRAWINGS FOR PLACEMENT OF SHELTERS ON SITES. INSTALLATION BY OTHERS
3. SEE LANDSCAPE DRAWINGS FOR SITE BENCHES & AMENITIES.
4. PROVIDE ACCESS HAND HOLE FOR CONNECTING SHELTER TO SITE UTILITY POWER. PROVIDE WIRING FOR LIGHTING & ELECTRONIC SIGN CONCEALED IN STRUCTURE.

VBN BUILDING
560 14th St.
Oakland, CA
94612
Tel: (510) 763-1313
Fax: (510) 465-1586

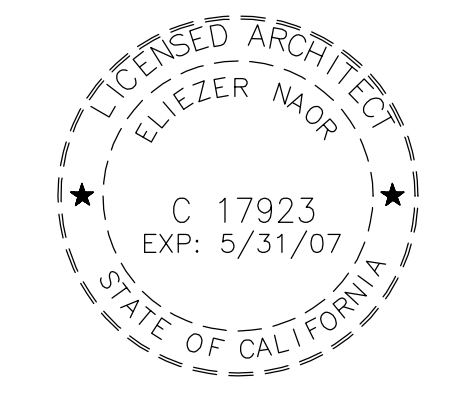

MAY 8, 2009

KEY NOTES

1. CONCRETE FOUNDATION, SEE CIVIL DWGS.
2. PROVIDE TEMPLATE FOR ALL INSERT PLACEMENT FOR SHELTER PER MANUFACTURER.

FINISH

- 1 METALLIC SILVER COATING
- 2 NOT USED
- 3 LAMINATED TEMPERED GLASS W/ RAPID LOGO IMAGE (SIGN TYPE 5)
- 4 3/8" TEMPERED GLASS W/ BAKED ON TRANSLUCENT SILVER WARNING BAND @ 3'
- 5 3/8" POLYCARBONATE TRANSLUCENT GLAZING, BRONZE TINT TO MATCH EXISTING SHELTERS ON DUBLIN BLVD.

ISSUES/REVISIONS		
NO.	DATE	DESCRIPTION

RAPID BUS STOP IMPROVEMENTS PROCUREMENT

DESIGNED BY: VL/PN/BNL	CHECKED BY: JA	APPROVED BY:
PROJECT NUMBER: SCALE: 1/4" = 1'-0"		097447005

PLANS DUBLIN STANDARD SHELTER

FILE INFO: F:\07002-LAVTA-R1e-0-BRT\000ADD\A202.dwg XREFS:XTBLK; XELEV-SECT-BASIC; XTBLK-Procurement PLOTTED: May 07, 2009 11:24am B:\bernard
 1
 2
 3
 4

E D C B A

SHEET NOTES

1. ALL FINISHES TO BE FURNISHED BY MFR., U.O.N.

VBN BUILDING
 560 14th St.
 Oakland, CA
 94612
 Tel: (510) 763-1313
 Fax: (510) 465-1586

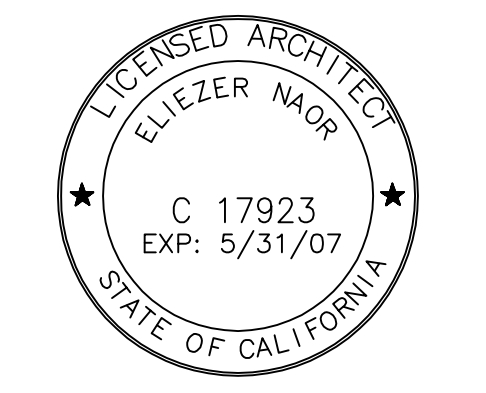

MAY 8, 2009

ISSUES/REVISIONS

NO.	DATE	DESCRIPTION

RAPID BUS STOP IMPROVEMENTS PROCUREMENT

DESIGNED BY: VL/PN/BNL	CHECKED BY: JA	APPROVED BY:
PROJECT NUMBER: 097447005		SCALE: 1/4" = 1'-0"

ELEVS. & SECTIONS
 RAPID BASIC & STANDARD SHELTERS

A-202
 7 OF 13

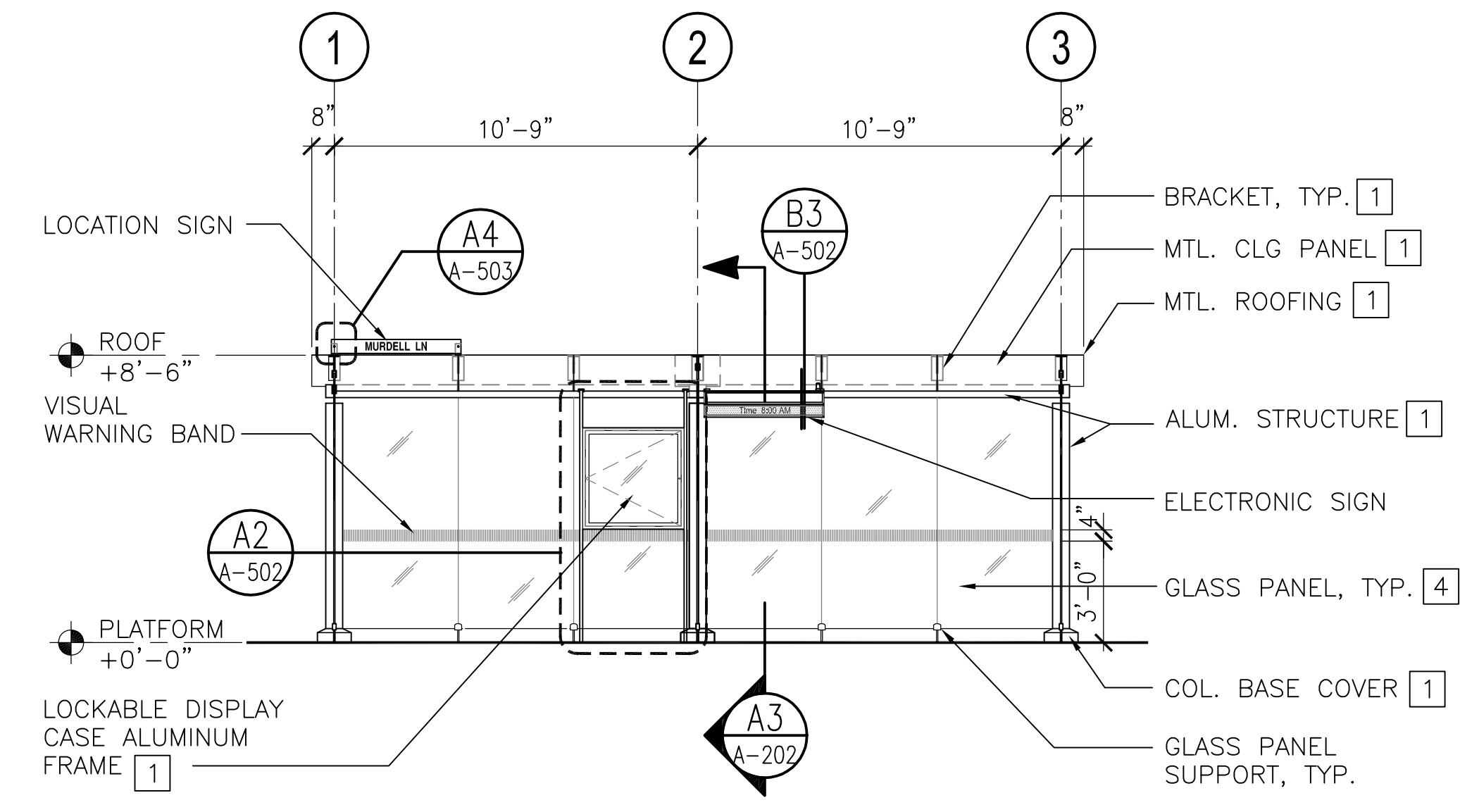

B2 FRONT ELEVATION - STANDARD
 A-202 SCALE: 1/4"=1'-0"

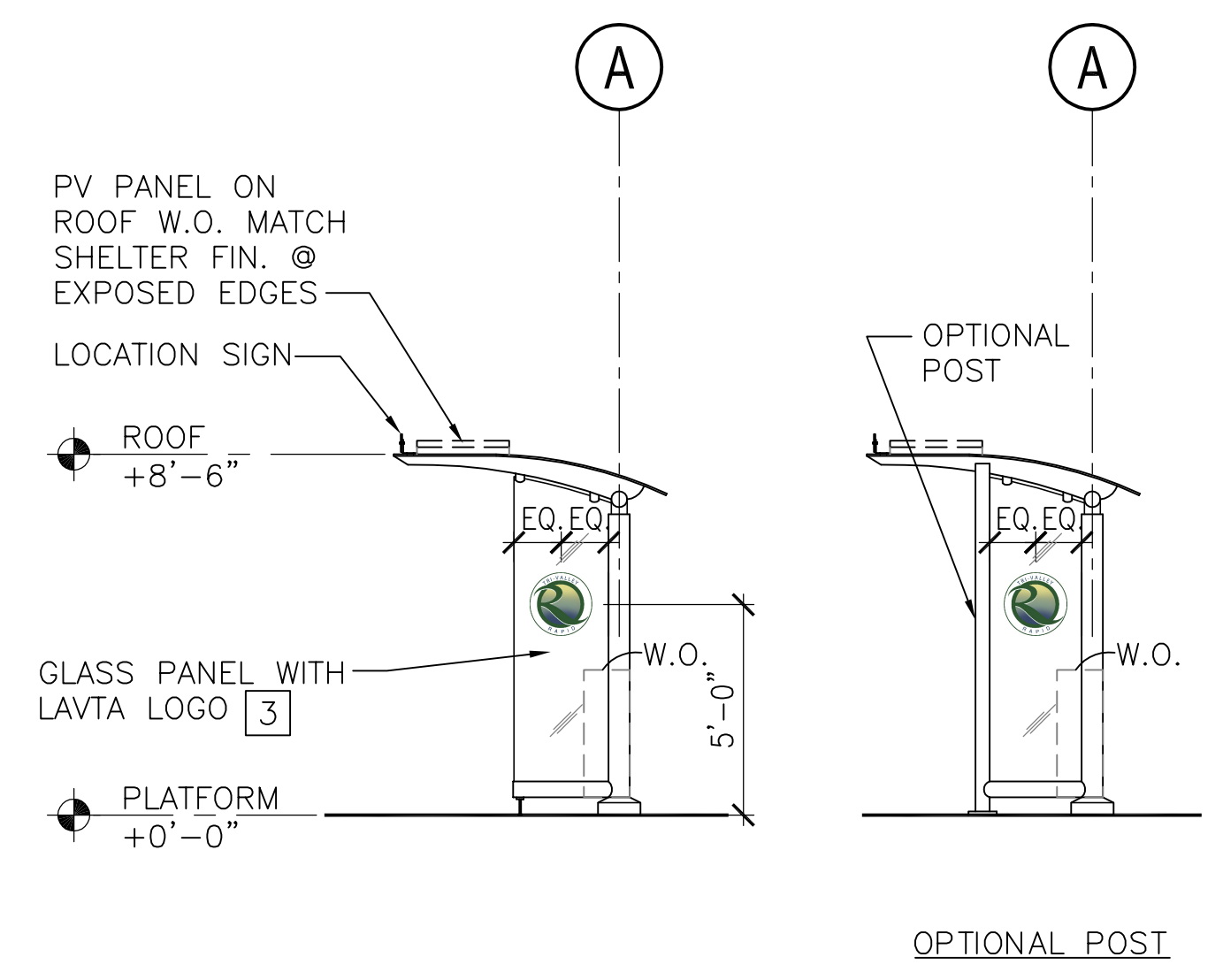

A1 SIDE ELEVATION - BASIC (STANDARD SIMILAR)
 A-202 SCALE: 1/4"=1'-0"

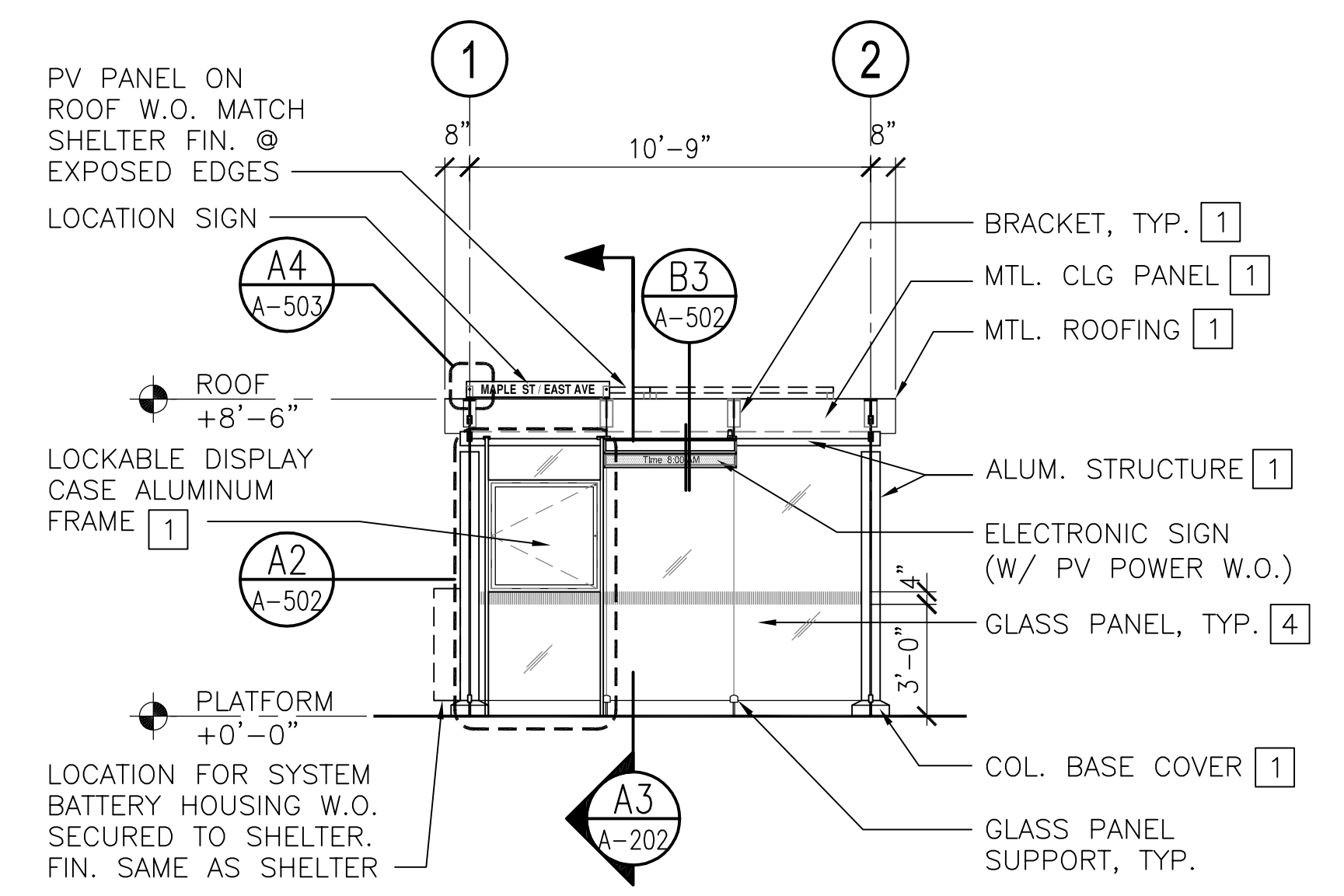

A2 FRONT ELEVATION - BASIC
 A-202 SCALE: 1/4"=1'-0"

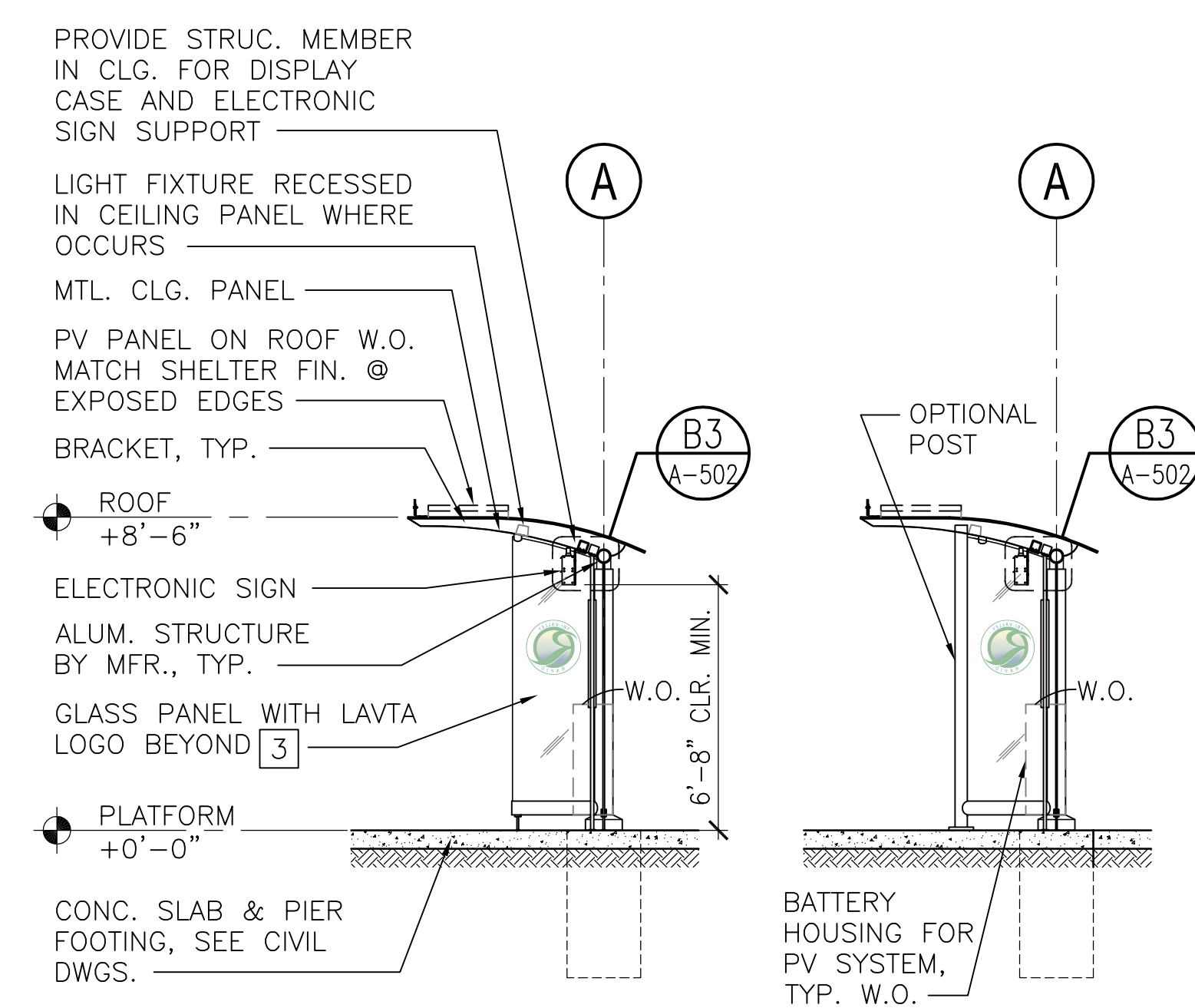

A3 SECTION - BASIC (STANDARD SIMILAR)
 A-202 SCALE: 1/4"=1'-0"

FILE INFO: F:\07002-LAVA-R1e10-BRT\000ADD_A203.dwg XREFS:XTBLK; XELEV-SECT-DUBLIN; XTBLK-Procurement PLOTTED: May 07, 2009 11:34am B:\bernard

E D C B A

SHEET NOTES

1. ALL FINISHES TO BE FURNISHED BY MFR., U.O.N.



VBN BUILDING
560 14th St.
Oakland, CA
94612
Tel: (510) 763-1313
Fax: (510) 465-1586

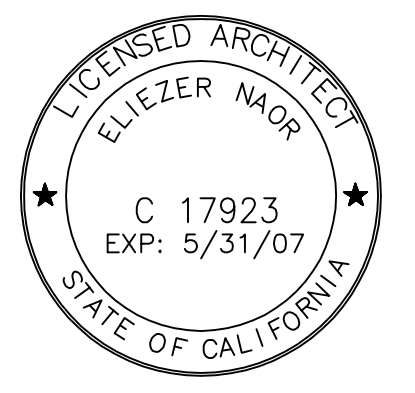

MAY 8, 2009

ISSUES/REVISIONS

NO.	DATE	DESCRIPTION

RAPID BUS STOP IMPROVEMENTS PROCUREMENT

DRAWN BY: VL/PN/BNL DESIGNED BY: JA CHECKED BY: JA APPROVED BY:
PROJECT NUMBER: 097447005
SCALE: 1/4" = 1'-0"

ELEV'S. & SECTIONS DUBLIN BASIC+STANDARD SHELTERS

A-203
8 OF 13

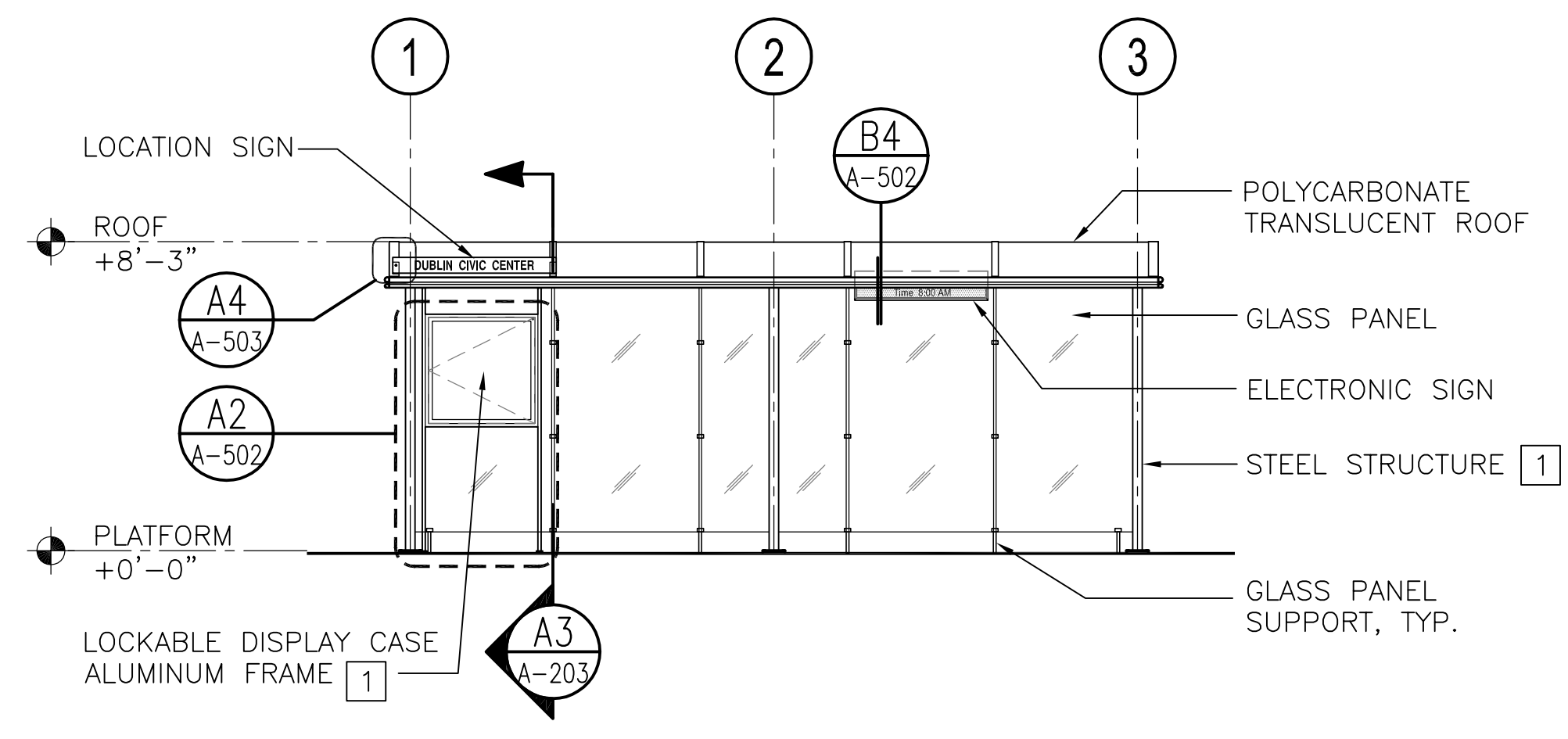

B2 FRONT ELEVATION - STANDARD
A-203 SCALE: 1/4"=1'-0"

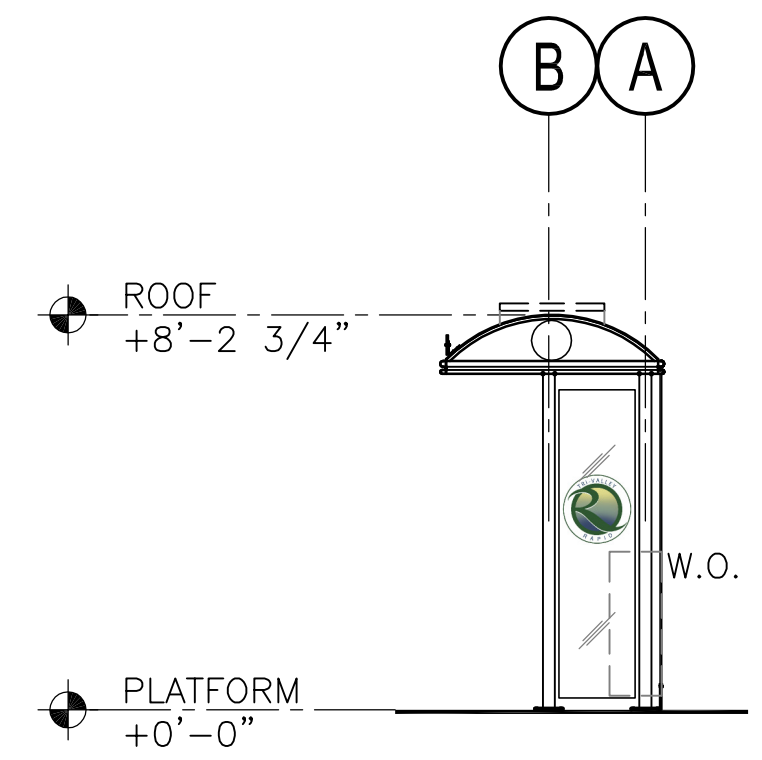

A1 SIDE ELEVATION - BASIC
A-203 SCALE: 1/4"=1'-0"

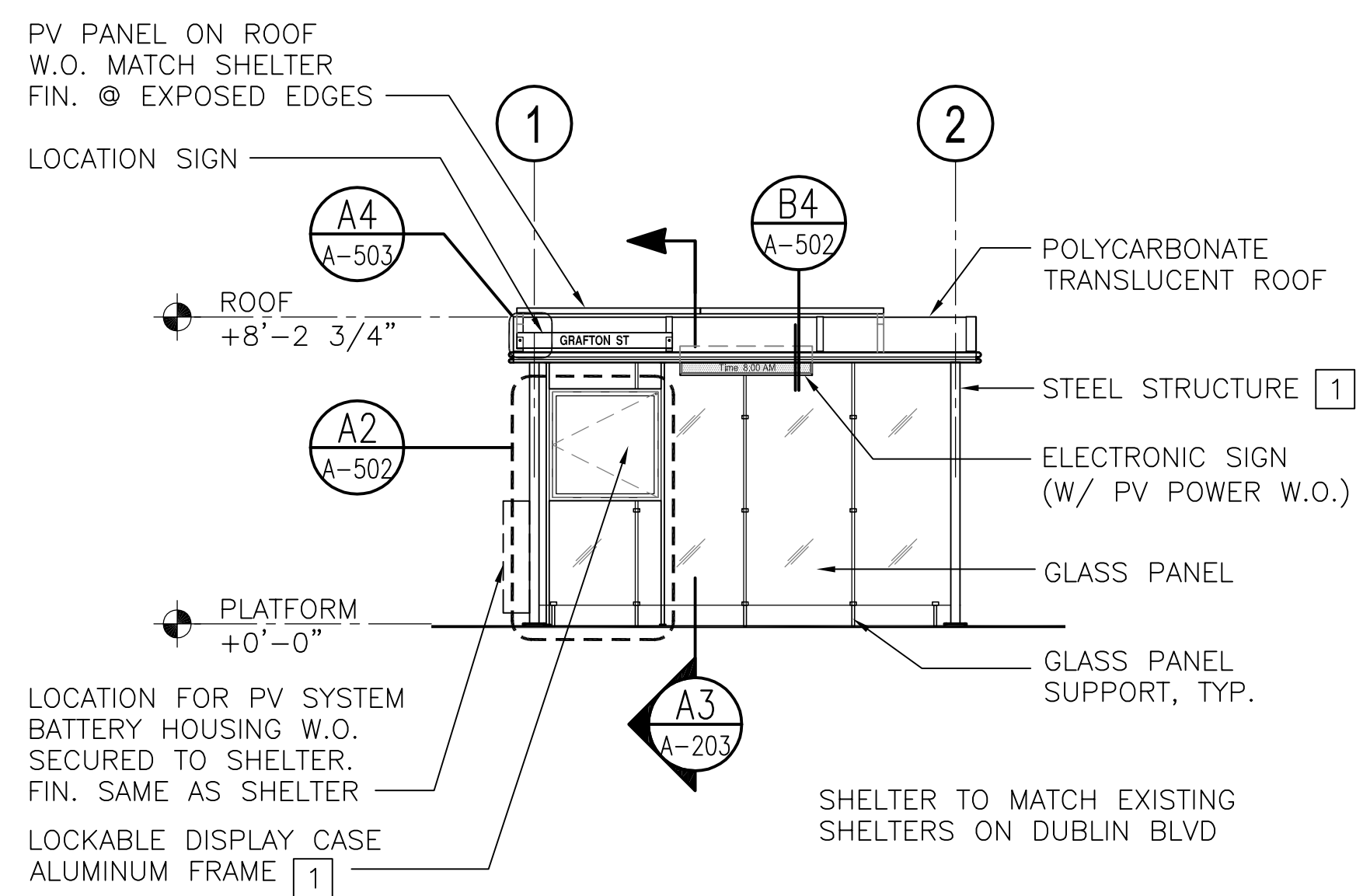

A2 FRONT ELEVATION - BASIC
A-203 SCALE: 1/4"=1'-0"

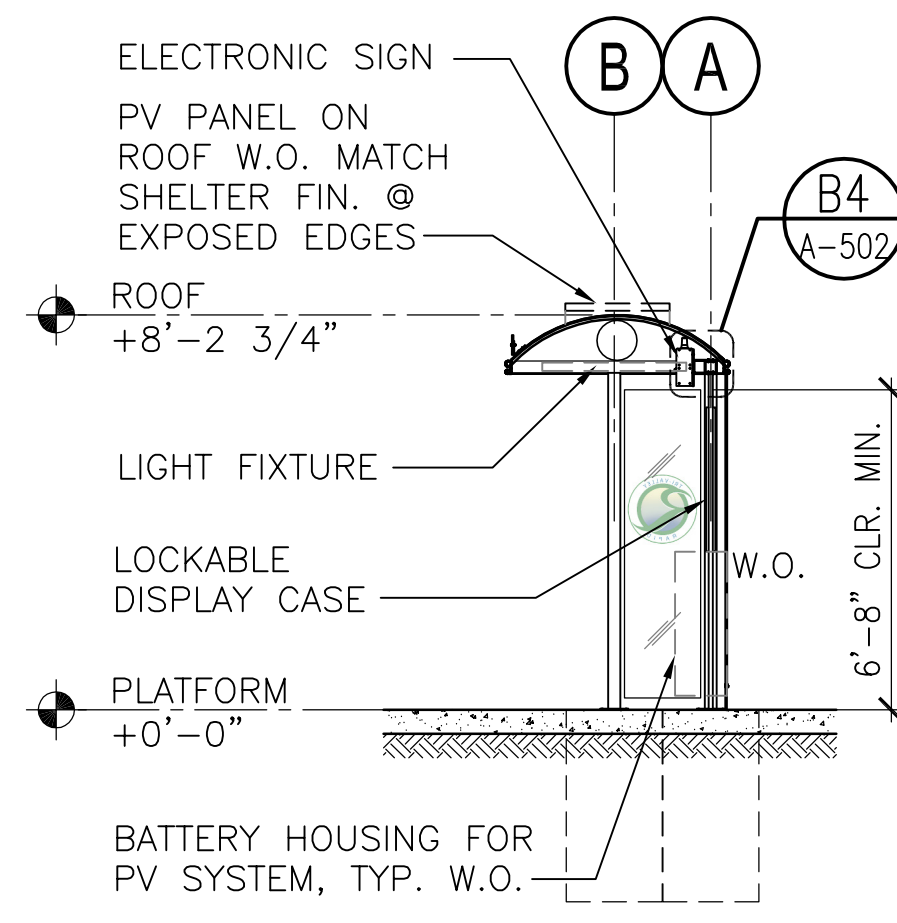

A3 SECTION - BASIC
A-203 SCALE: 1/4"=1'-0"

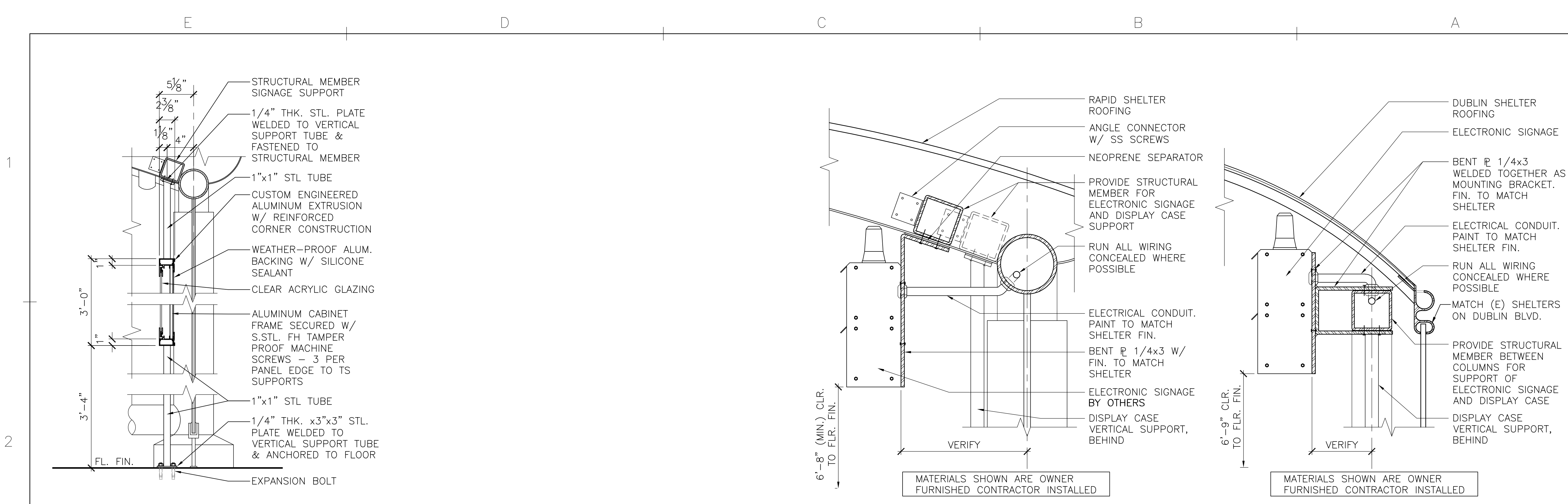

B1 SECTION – DISPLAY CASE (FLR. MTD.)
 A-502 SCALE: 1 1/2" = 1'-0"

B3 RAPID SHELTER ELECTRONIC ARRIVAL SIGN MOUNTING
 A-502 SCALE: 3" = 1'-0"

B4 DUBLIN SHELTER ELECTRONIC ARRIVAL SIGN MOUNTING
 A-502 SCALE: 3" = 1'-0"

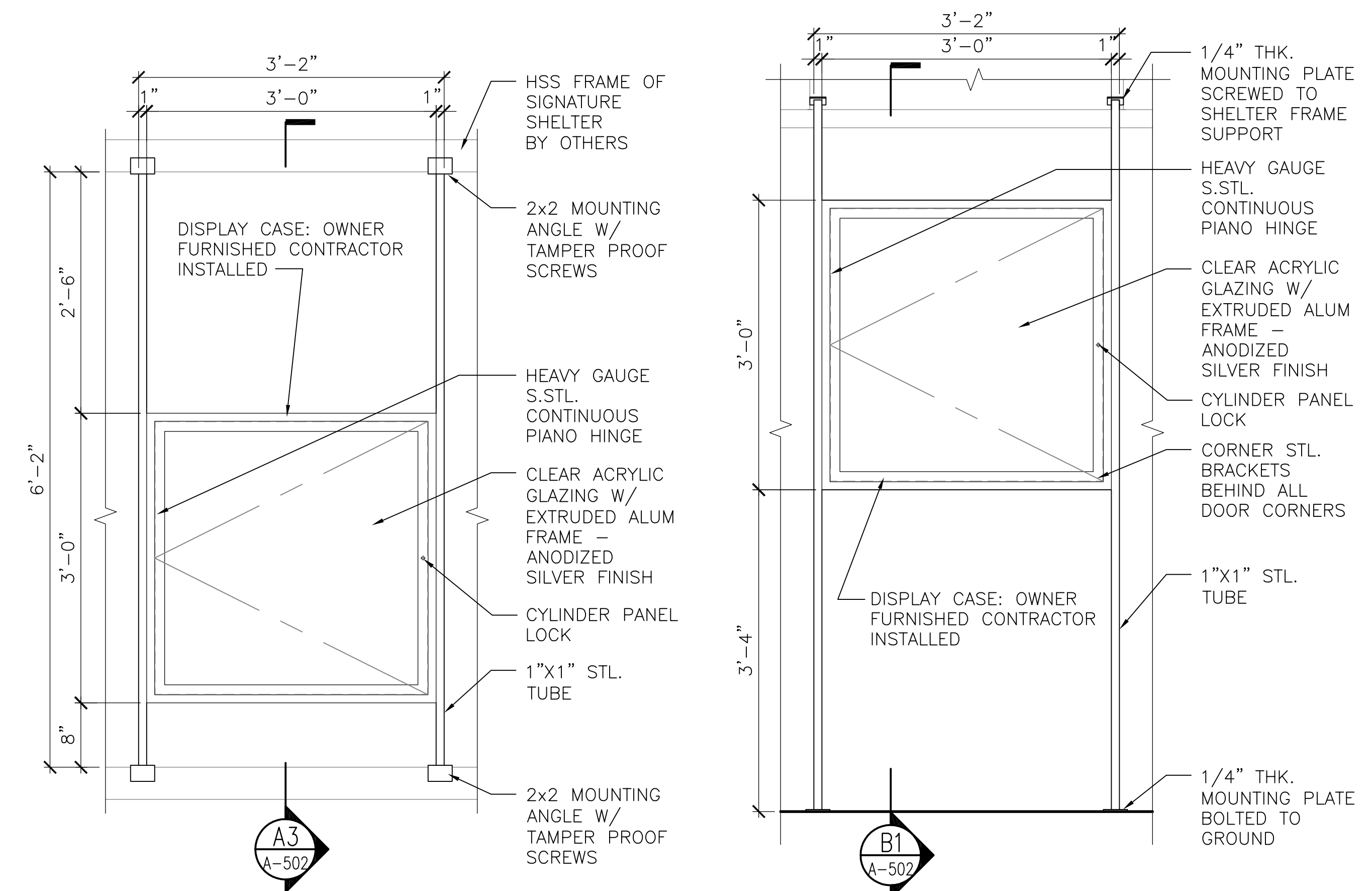

A1 FRONT ELEVATION – SIGNATURE SHELTER DISPLAY CASE (FLR./CLG. SUPPORTED)
 A-502 SCALE: 1" = 1'-0"

A2 FRONT EL. – BASIC/STANDARD SHELTER DISPLAY CASE (FLR./CLG. SUPPORTED)
 A-502 SCALE: 1" = 1'-0"

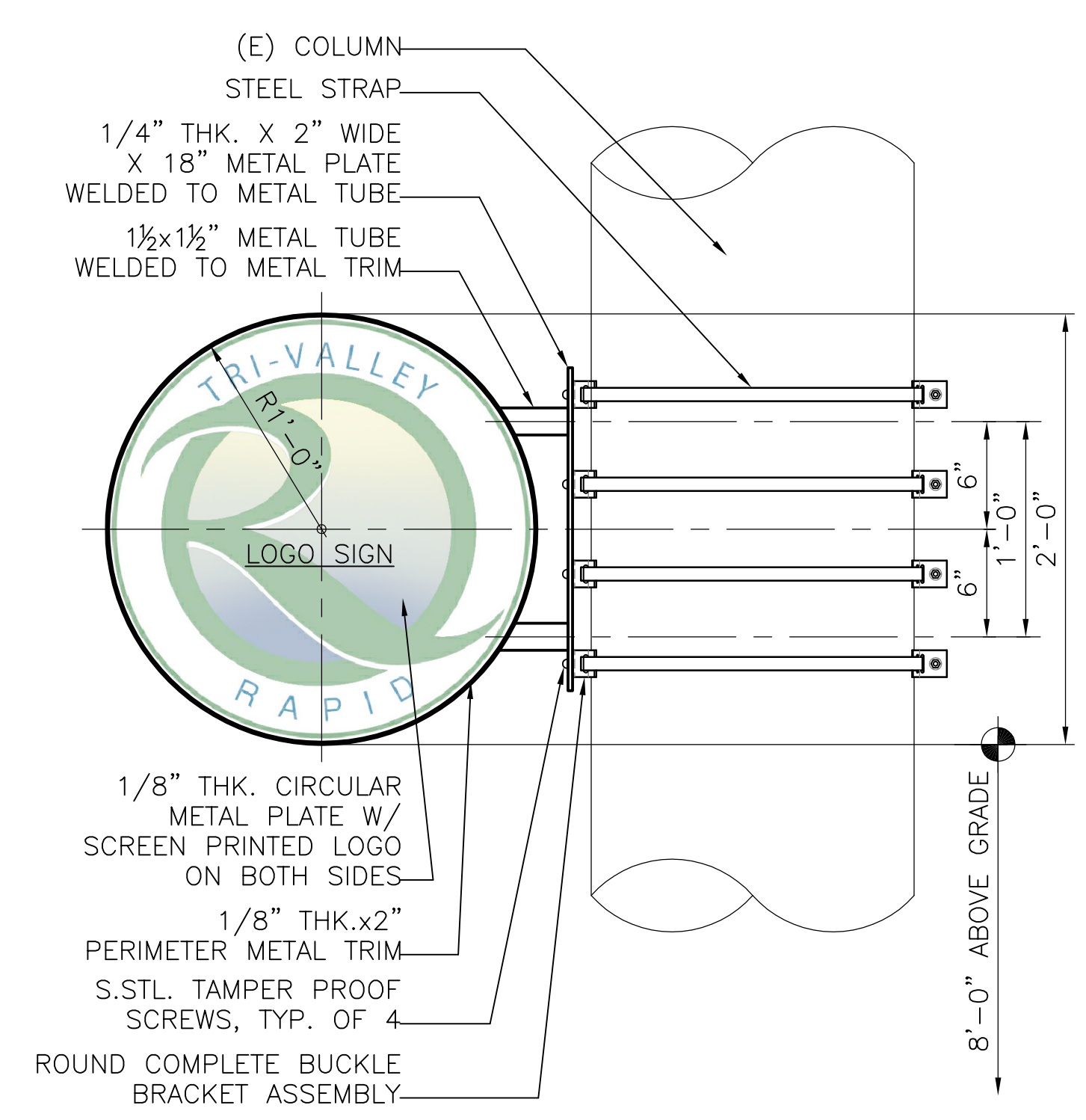

(SIGN TYPE 6)
A4 LOGO – COLUMN MOUNTED
 A-502 SCALE: 1" = 1'-0"

VBN BUILDING
 560 14th St.
 Oakland, CA
 94612
 Tel: (510) 763-1313
 Fax: (510) 465-1586

LICENSED ARCHITECT
 ELIEZER NAOR
 C 17923
 EXP: 5/31/07
 STATE OF CALIFORNIA



MAY 8, 2009

ISSUES/REVISIONS

NO.	DATE	DESCRIPTION

RAPID BUS STOP IMPROVEMENTS PROCUREMENT

PROJECT NUMBER: 097447005
 SCALE: 1/4" = 1'-0"

DETAILS – DISPLAY CABINET ELECTRONIC SIGN

A-502
 9 OF 13

FILE INFO: F:\07002-LAVA-Rie-0-BRT\000ADD\A502.dwg XREFS:XTBLK; XTBLK-Phase 1; XTBLK-Procurement PLOTTED: May 07, 2009 11:37am Bribbard

E

D

C

B

A

ELECTRONIC SIGN TO BE FURNISHED & INSTALLED BY OTHERS.

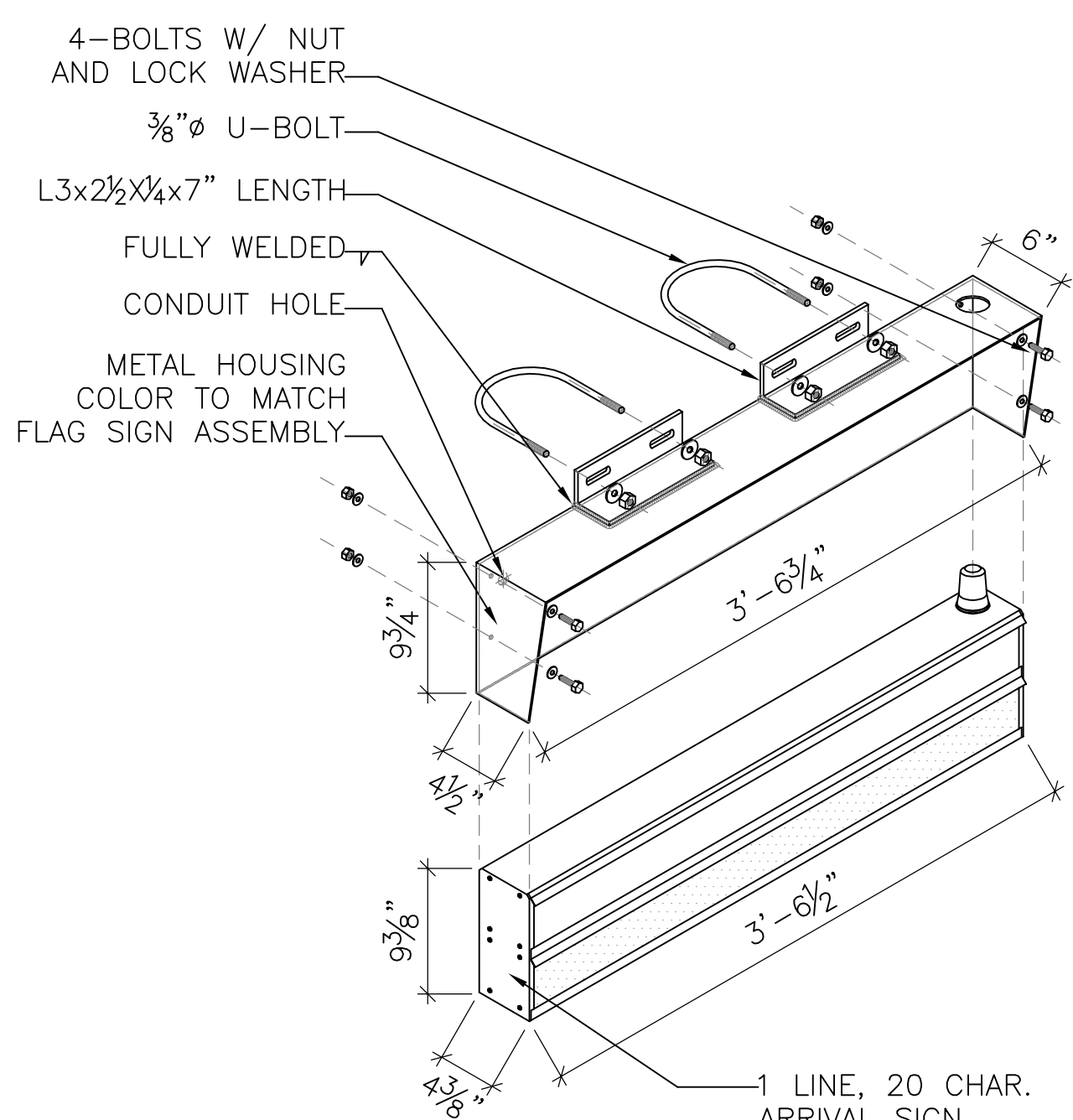

B1 ELECTRONIC ARRIVAL & ARRIVAL SIGN HOUSING - ISOMETRIC
A-503 SCALE: 1" = 1'-0"

ELECTRONIC SIGN TO BE FURNISHED & INSTALLED BY OTHERS.

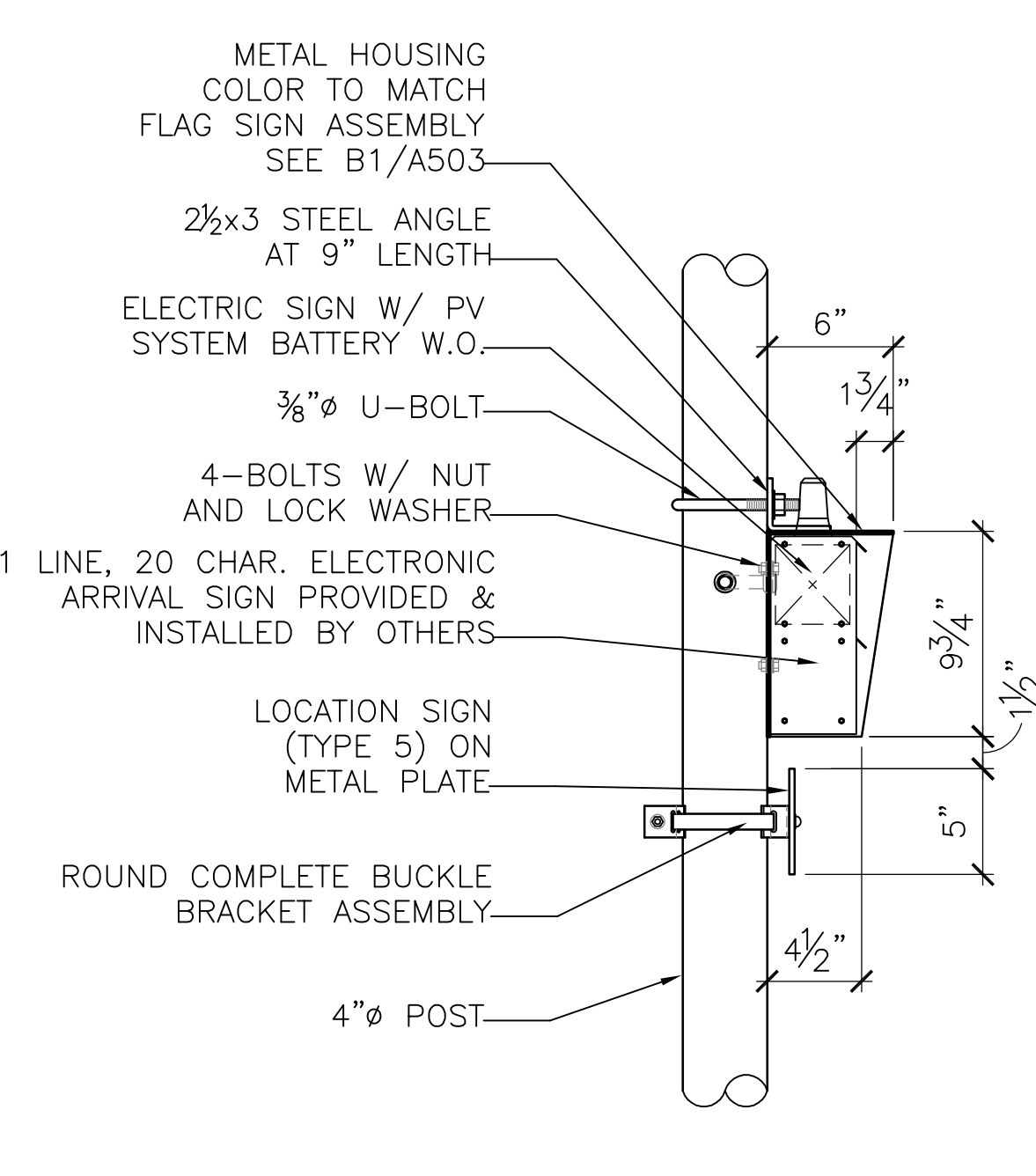

B3 ELECTRONIC ARRIVAL SIGN & LOCATION SIGN (SIGN TYPE 2) MOUNTING - SECTION
A-503 SCALE: 1 1/2" = 1'-0"

ELECTRONIC SIGN TO BE FURNISHED & INSTALLED BY OTHERS.

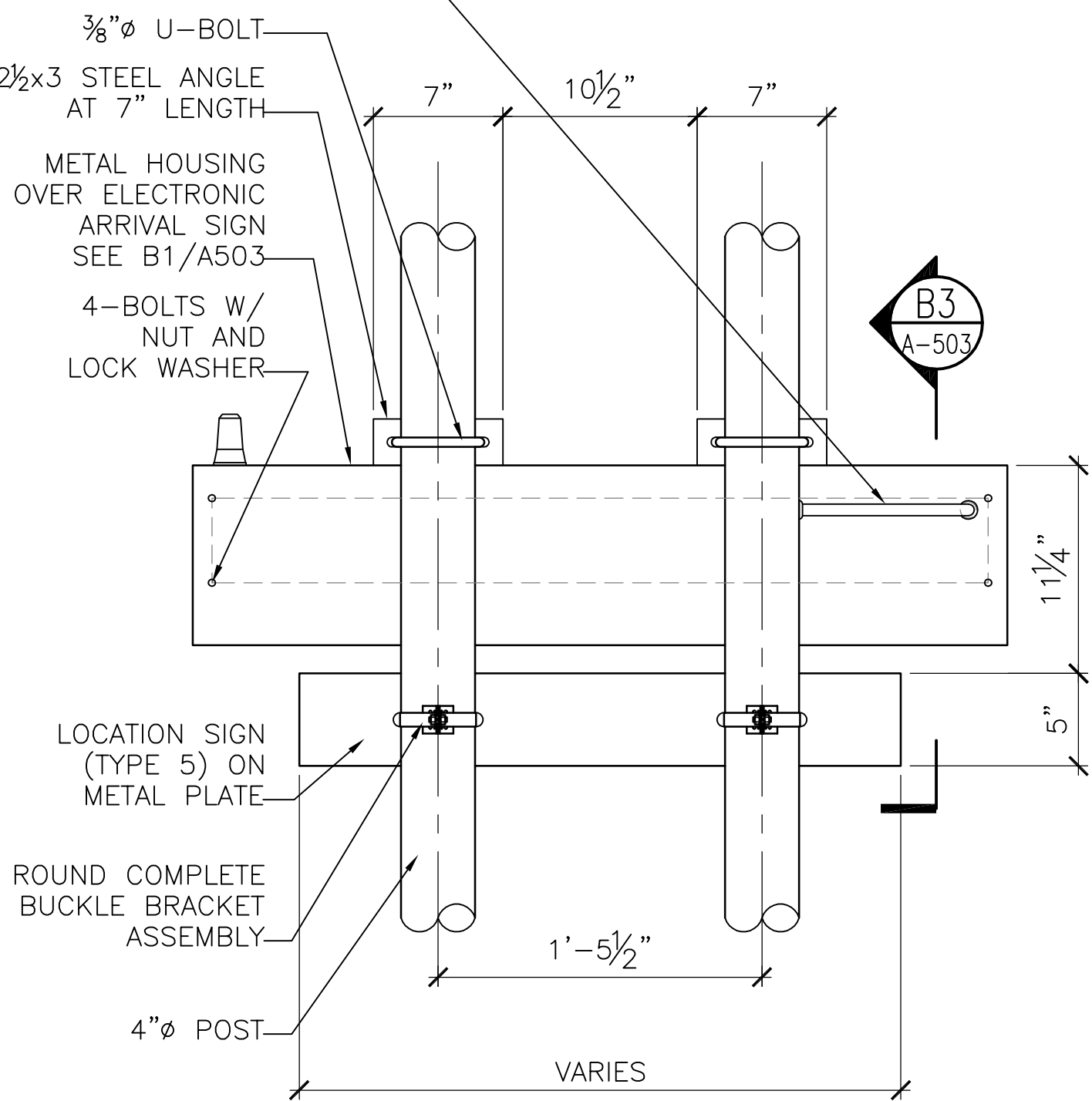

B4 ELECTRONIC ARRIVAL SIGN & LOCATION SIGN (SIGN TYPE 2) MOUNTING - REAR ELEV.
A-503 SCALE: 1 1/2" = 1'-0"

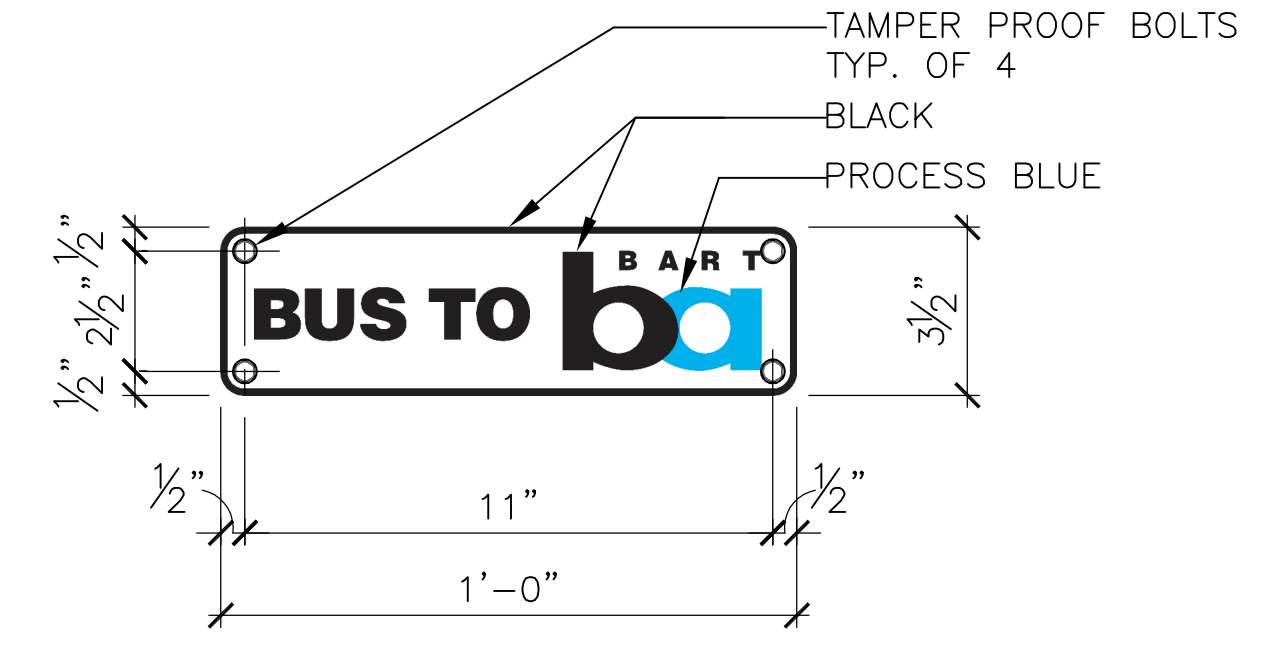
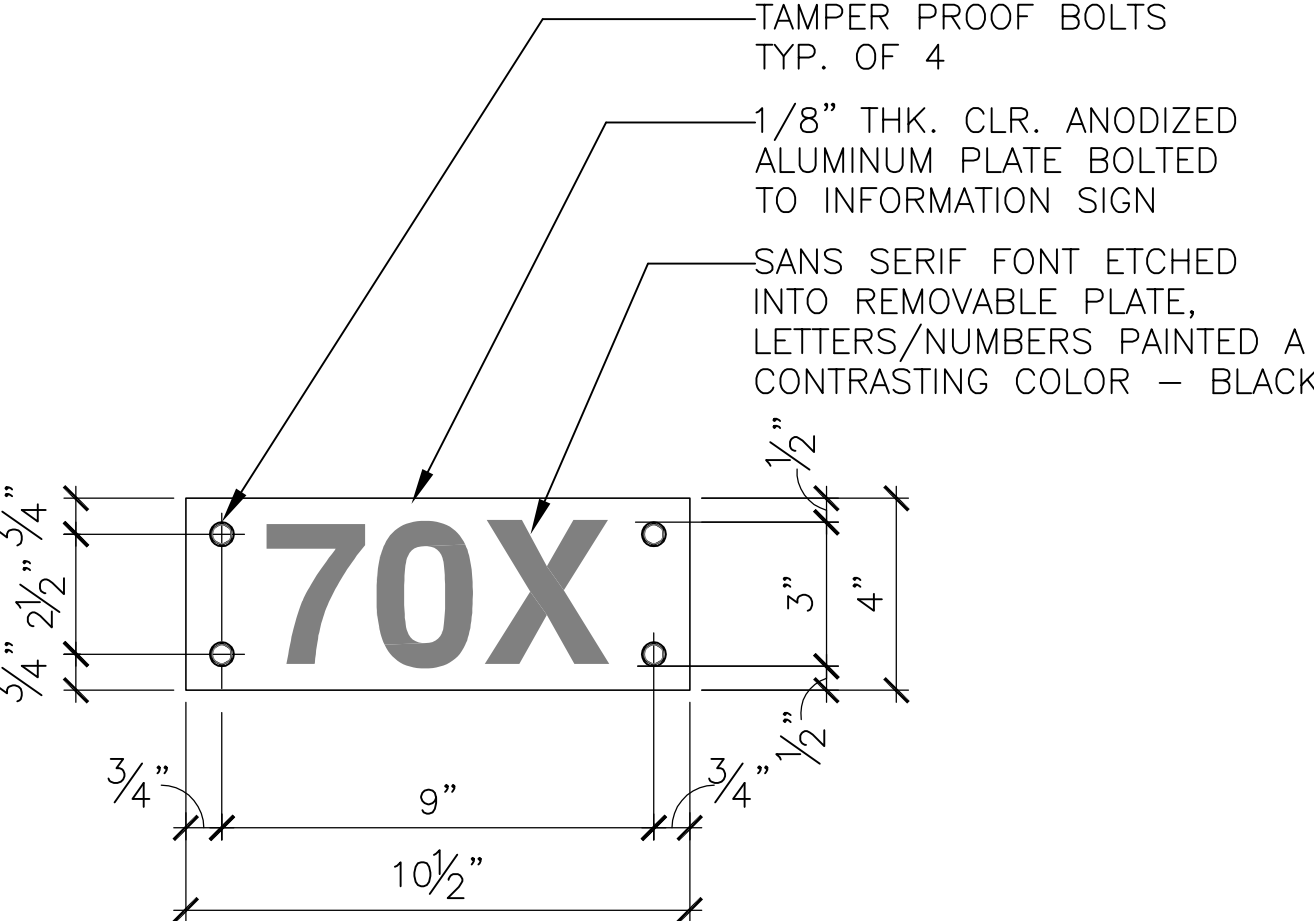

B2 BUS STOP ROUTE SIGN GRAPHICS
A-503 SCALE: 3" = 1'-0"

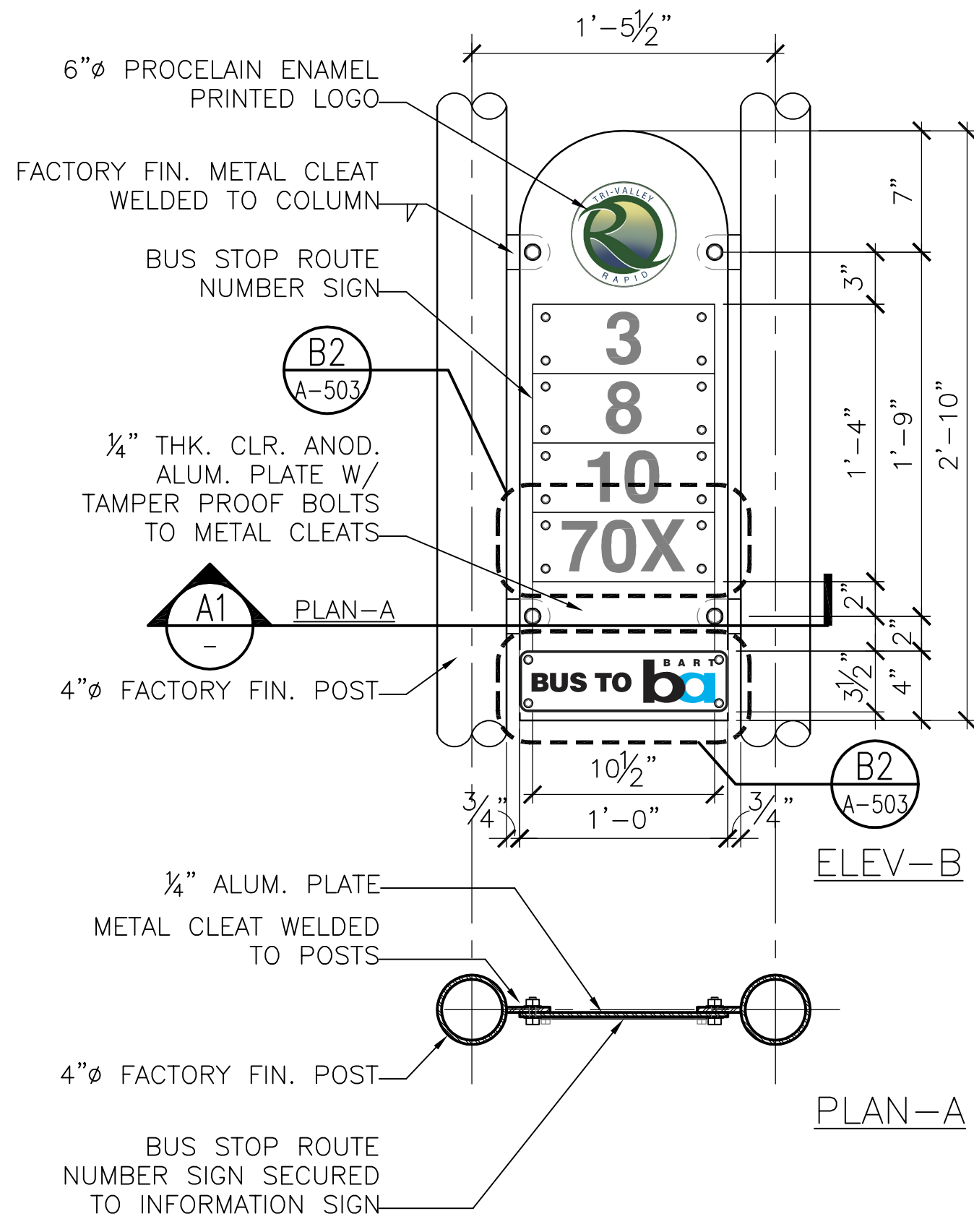

A1 (SIGN TYPE 3) BUS ROUTE SIGN - PLAN/ELEV.
A-503 SCALE: 1 1/2" = 1'-0"

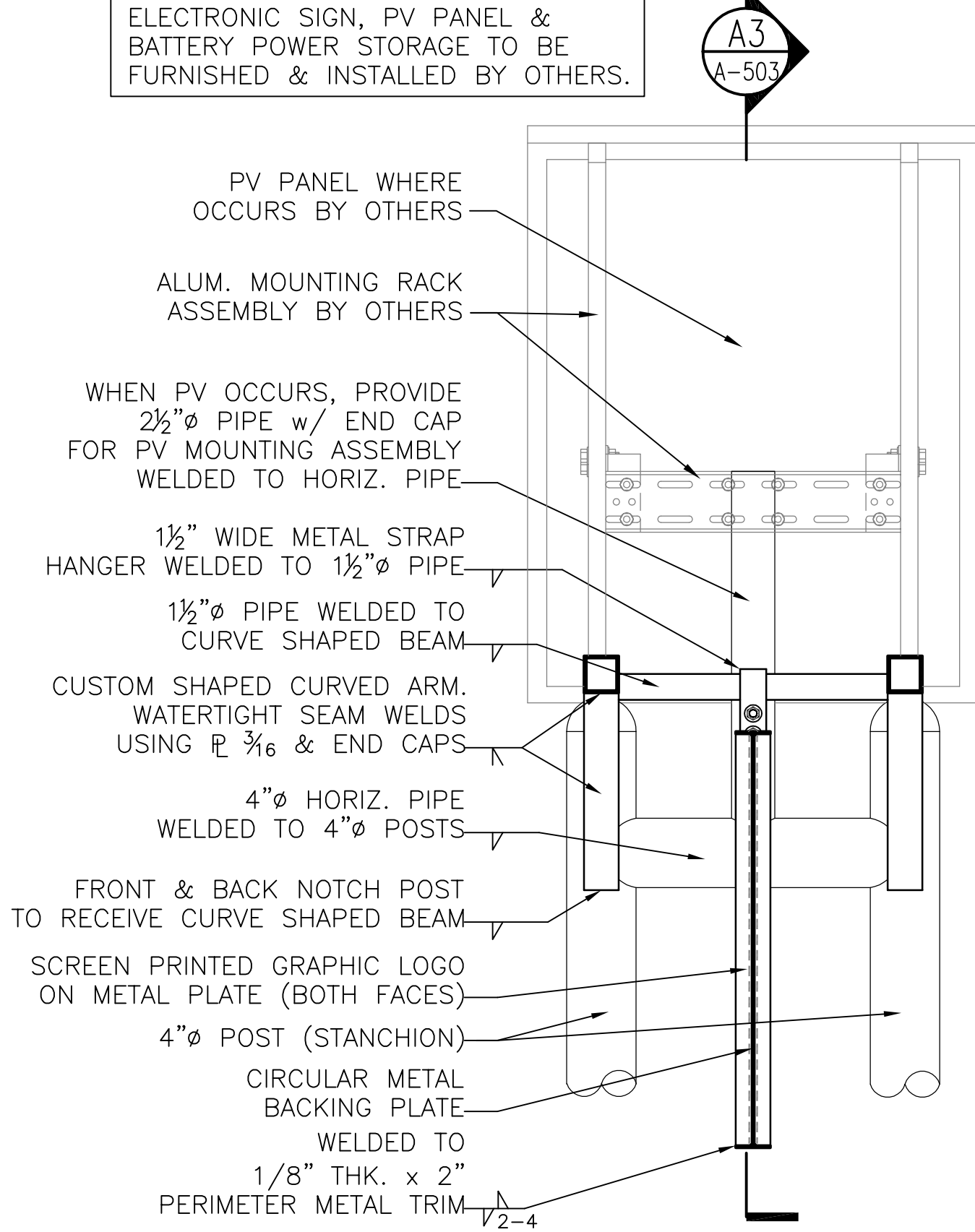

A2 LOGO & CURVED ARM - SECTION
A-503 SCALE: 1 1/2" = 1'-0"

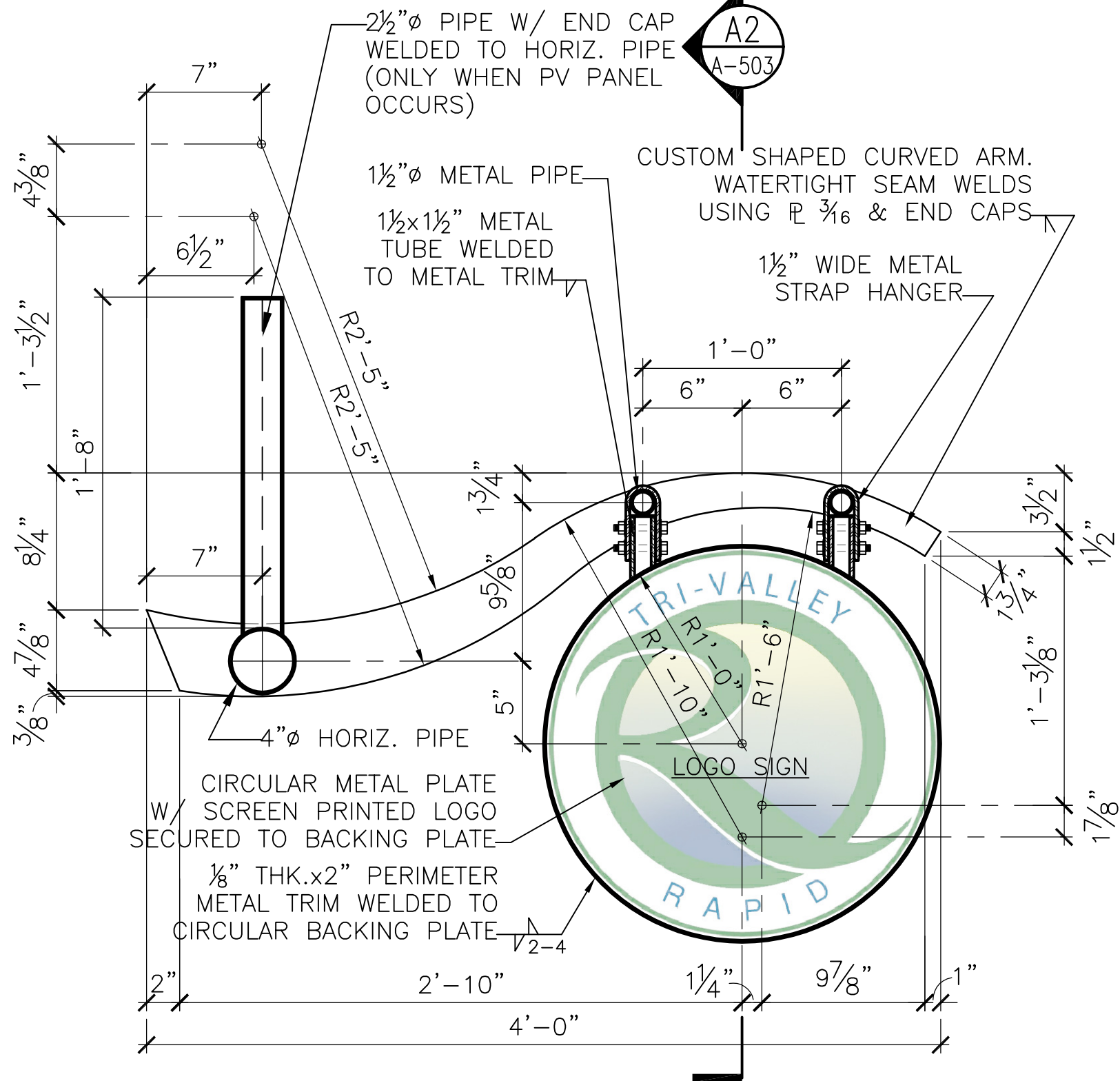

A3 (SIGN TYPE 1) LOGO & CURVED ARM - LONGITUDINAL SECTION
A-503 SCALE: 1 1/2" = 1'-0"

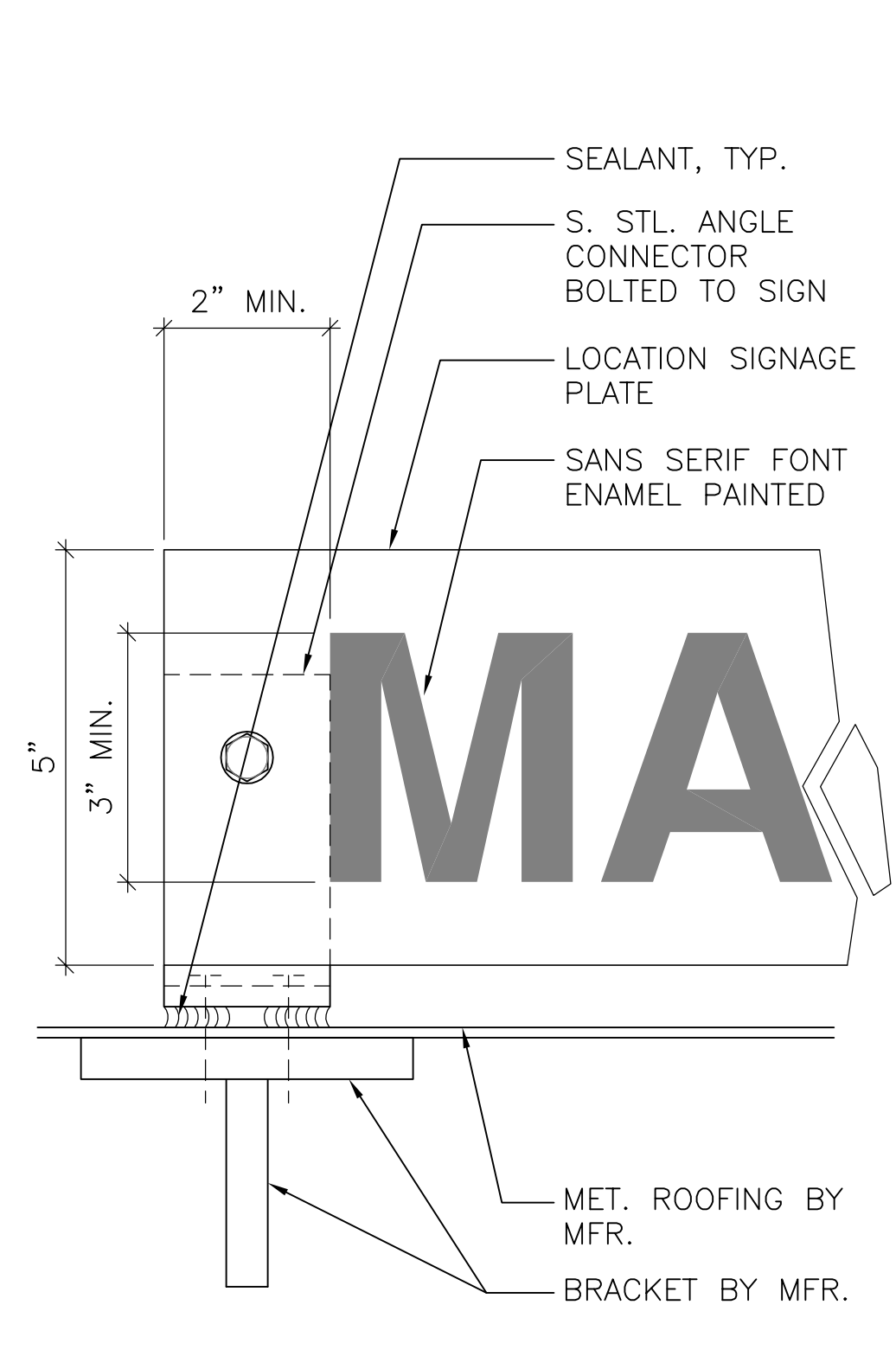

A4 (SIGN TYPE 4) LOCATION SIGN MOUNTING DETAIL
A-503 SCALE: 6" = 1'-0"

FILE INFO: F:\07002-JAVA-R1e-BRT-Procurement PLOTTED: May 07, 2009 11:35am By:bernard
XREFS:XTBLK; XTBLK-Phase 1; XTBLK-Procurement PLOTTED: May 07, 2009 11:35am By:bernard

VBN BUILDING
560 14th St.
Oakland, CA
94612
Tel: (510) 763-1313
Fax: (510) 465-1586

LICENSED ARCHITECT
ELEZER NAOR
C 17923
EXP: 5/31/07
STATE OF CALIFORNIA

Wheels

MAY 8, 2009
ISSUES/REVISIONS

NO.	DATE	DESCRIPTION

RAPID BUS STOP IMPROVEMENTS PROCUREMENT

DESIGNED BY: VL/PN/BNL	CHECKED BY: JA	APPROVED BY:
PROJECT NUMBER: SCALE:		097447005 AS NOTED

DETAILS
ELECTRONIC, LOCATION,
BUS STOP ROUTE & FLAG
SIGNS

ELECTRICAL DRAWINGS



ELECTRICAL SYMBOL LIST

* This is a standard list and not all symbols and abbreviations may be used.

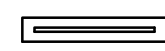
LIGHTING

-  RECESSED LED LUMINAIRE
-  STRIP LED LUMINAIRE

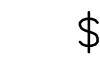

SWITCHES AND RECEPTACLES

-  WEATHERPROOF SINGLE POLE SWITCH
-  SWITCHED PHOTOCELL

CONNECTIONS / EQUIPMENT

-  WEATHERPROOF JUNCTION BOX

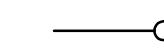
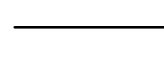
MISCELLANEOUS

-  CONDUIT ELLED UP
-  CONDUIT CONCEALED IN WALL OR CEILING SPACE
-  CONDUIT ROUTED BELOW FLOOR / GRADE
-  REFERENCE NOTE

ABBREVIATIONS

- A AMPERES, AMBER
- AFF ABOVE FINISHED FLOOR
- AFG ABOVE FINISHED GRADE
- C CONDUIT, CLOSE, CONTROL
- CLG CEILING
- CU COPPER
- GFCI GROUND FAULT CIRCUIT INTERRUPTER
- GFI GROUND FAULT INTERRUPTER
- TYP TYPICAL
- UL UNDERWRITERS LABORATORIES
- V VOLTS, VOLTAGE
- WP WEATHERPROOF

GENERAL ELECTRICAL NOTES

- A. ALL WORK IS TO BE CONSTRUCTED IN ACCORDANCE WITH CURRENT LOCAL AND STATE CODES.
- B. COORDINATE EXACT LOCATION AND MOUNTING HEIGHT OF LUMINAIRES AND LIGHTING CONTROLS WITH ARCHITECT PRIOR TO INSTALLATION.
- C. WIRING TO BE CONCEALED AND ROUTED THROUGH STRUCTURE.
- D. WHERE APPLICABLE, WIRING FOR PV SYSTEM TO BE CONCEALED AND ROUTED THROUGH STRUCTURE.
- E. PV SYSTEM SHALL COMPLY WITH CEC SECTION 690. SUBMIT COMPLETE DRAWINGS FOR APPROVAL AND ASSUME FULL RESPONSIBILITY FOR SYSTEM.
- F. REFER TO SPECIFICATIONS FOR ADDITIONAL REQUIREMENTS.
- G. DRAWINGS AND SPECIFICATIONS COMPLIMENT EACH OTHER. REQUIREMENT BY EITHER INFERS REQUIREMENT BY BOTH.
- H. PROVIDE CONCEALED AND FLUSH MOUNTED INSTALLATION OF DEVICES AND EQUIPMENT IN AREAS, U.O.N.
- I. LIGHTS, SWITCHES AND CONTROL MECHANISMS SHALL COMPLY WITH CEC SECTION 404.

VBN BUILDING
 560 14th St.
 Oakland, CA
 94612
 Tel: (510) 763-1313
 FAX: (510) 465-1586



MAY 8, 2009

ISSUES/REVISIONS

NO.	DATE	DESCRIPTION

RAPID BUS STOP IMPROVEMENTS PROCUREMENT

PROJECT: 2008-0581
 CONTRACT: Ray Juachon
 717 Market Street
 Suite 500
 San Francisco, CA 94103
 TEL: 415.489.7249
 FAX: 415.489.7289
 www.interfaceengineering.com



DESIGNED BY: RJ	DRAWN BY: JL	CHECKED BY:	APPROVED BY:
--------------------	-----------------	-------------	--------------

PROJECT NUMBER: 097447005
 SCALE: SEE PLAN

ELECTRICAL SYMBOL LIST, GENERAL NOTES, PV SYSTEM BLOCK DIAGRAM, & SHEET INDEX

E-001

12 OF 13

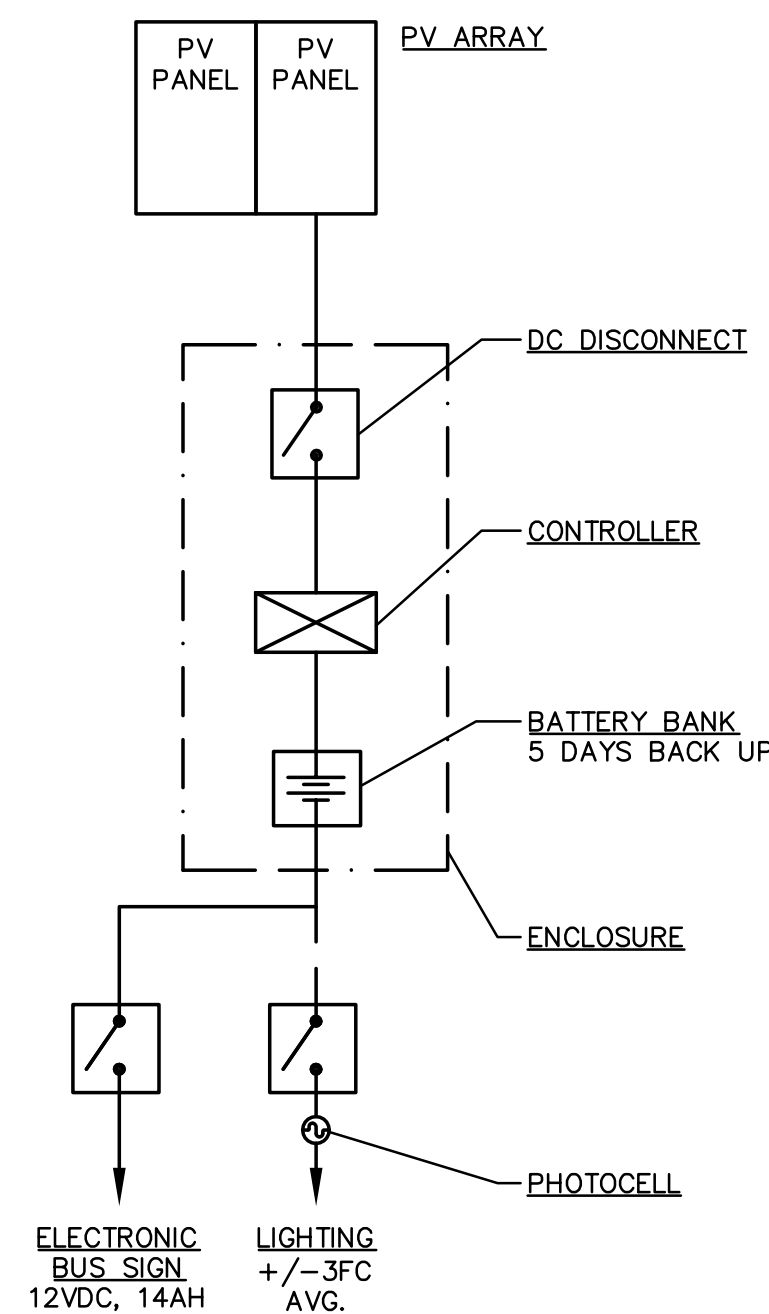

1 PV BLOCK DIAGRAM - BUS SHELTER
 NO SCALE

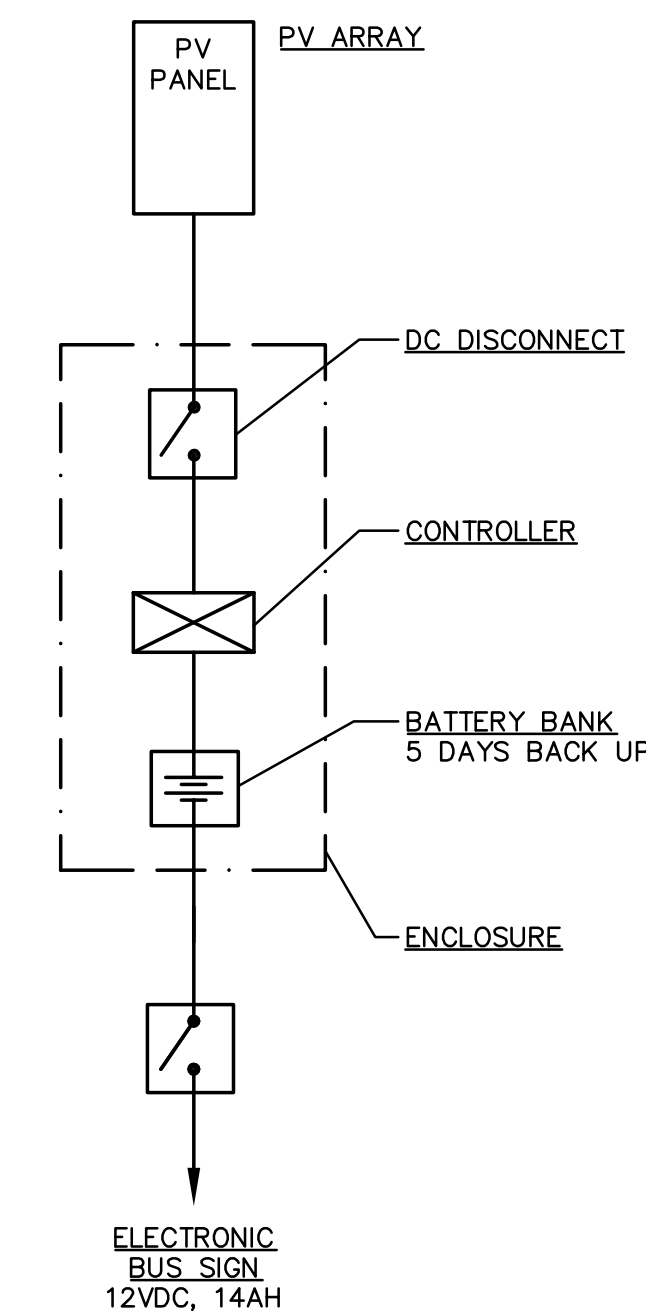

2 PV BLOCK DIAGRAM - FLAG SIGN
 NO SCALE

SHEET INDEX

- E-001 ELECTRICAL SYMBOL LIST, GENERAL NOTES, PV SYSTEM BLOCK DIAGRAM, & SHEET INDEX
- E-110 ELECTRICAL PLANS

GENERAL NOTES

- A. VERIFY POWER REQUIREMENTS OF SIGN MANUFACTURER PRIOR TO FABRICATION AND SIZING OF PV SYSTEM. OBTAIN SHOP DRAWING FROM MANUFACTURER.
- B. REFER TO ARCHITECTURAL DRAWINGS FOR MOUNTING OF PHOTOVOLTAIC SYSTEM COMPONENTS AND LUMINAIRES.
- C. CONCEAL ALL WIRING AND CONDUITS WITHIN SHELTER COLUMNS. PROVIDE NECESSARY HANDHOLES FOR FIELD INSTALLATIONS AND MAINTENANCE.
- D. JUNCTION BOXES AND SWITCHES SHOWN SHALL BE WEATHERPROOF.
- E. REFER TO E-001 FOR PHOTOVOLTAIC SYSTEM BLOCK DIAGRAMS.

SHEET KEYNOTES

- ① LIGHTING SHALL BE CONTROLLED VIA PHOTOCELL LOCATED ON ROOF OF SHELTER. PROVIDE LOCAL DISCONNECT SWITCH ACCESSIBLE TO AUTHORIZED PERSONNEL ONLY.
- ② PROVIDE PHOTOVOLTAIC SYSTEM SIZE REQUIRED TO POWER LIGHTING AND ELECTRONIC SIGN AND SHALL INCLUDE PANELS TO FIT ON ROOF OF SHELTER.
- ③ PROVIDE JUNCTION BOX AND SWITCH FOR CONNECTION ELECTRONIC SIGN PROVIDED UNDER SEPARATE CONTRACT.. SIGN SHALL OPERATE 24 HOURS A DAY.
- ④ TERMINATE WIRING AT HANDHOLE FOR CONNECTION TO UNDERGROUND POWER SUPPLY PROVIDED BY OTHERS.
- ⑤ LIGHTING SYSTEM AS SHOWN SHALL PROVIDE MINIMUM 3 FOOT-CANDLE AT FLOOR OF SHELTER AND SHALL OPERATE FROM DUSK UNTIL DAWN. COORDINATE OPERATING VOLTAGE WITH POWER SUPPLY (UNDERGROUND OR PHOTOVOLTAIC).
- ⑥ BATTERY BANK SHALL BE SIZED WITH 5 DAYS MINIMUM BACK UP. COORDINATE EXACT LOCATION OF ENCLOSURE WITH ARCHITECTURAL PLANS.

VBN BUILDING
 560 14th St.
 Oakland, CA
 94612
 Tel: (510) 763-1313
 Fax: (510) 465-1586

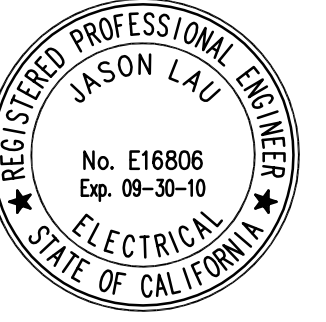

MAY 8, 2009

ISSUES/REVISIONS

NO.	DATE	DESCRIPTION
-----	------	-------------

RAPID BUS STOP IMPROVEMENTS PROCUREMENT

PROJECT: 2008-0581
 CONTRACT: Ray Juachon
INTERFACE ENGINEERING
 717 Market Street
 Suite 500
 San Francisco, CA 94103
 TEL: 415.489.7249
 FAX: 415.489.7289
 www.interfaceengineering.com

DESIGNED BY: RJ	CHECKED BY: JIL	DATE: 5/7/2009	PROJECT NUMBER: 097447005
-----------------	-----------------	----------------	---------------------------

ELECTRICAL PLANS

E-110

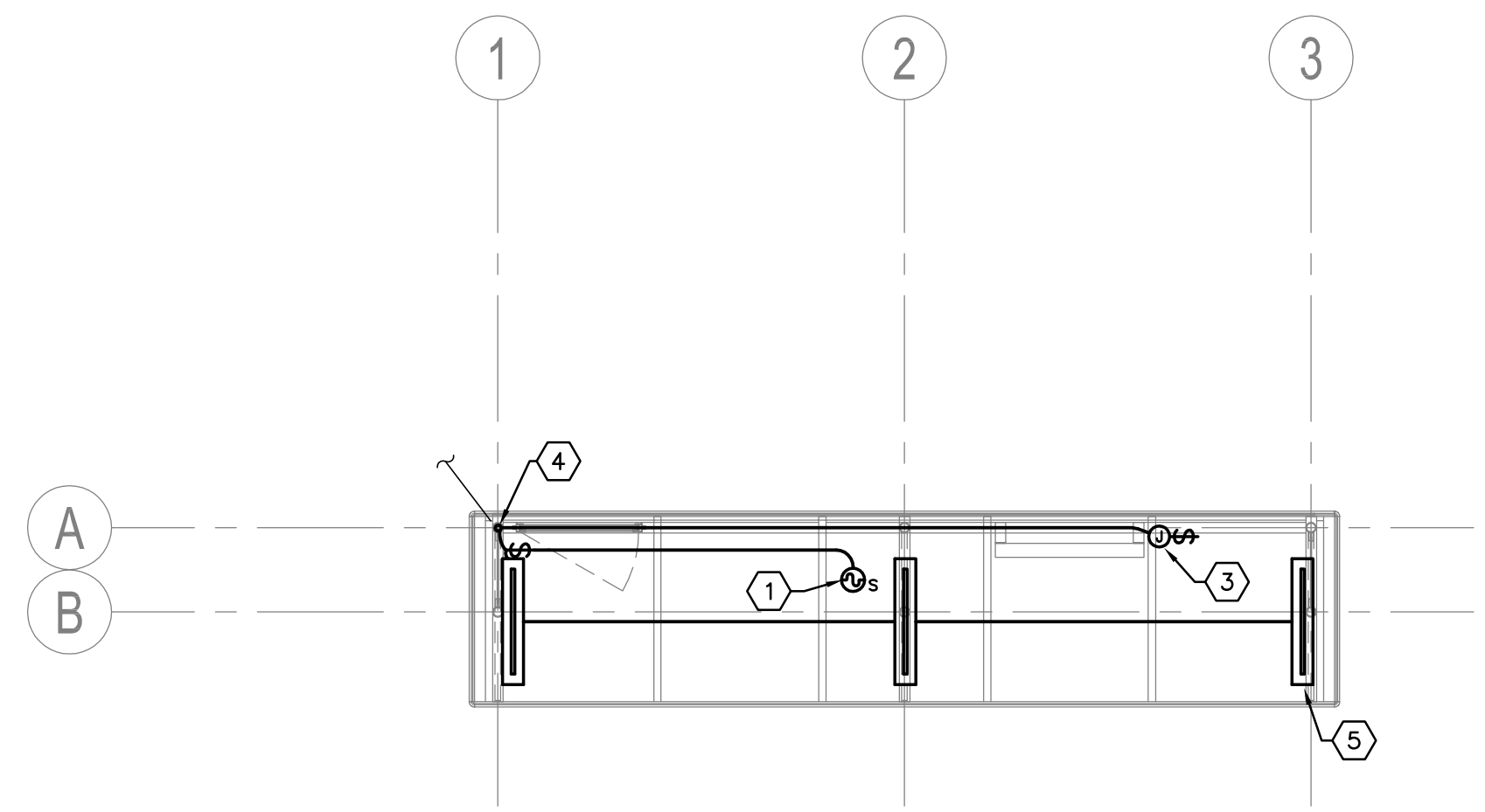

6 DUBLIN STANARD - ELECTRICAL
 SCALE: 1/4"=1'-0"

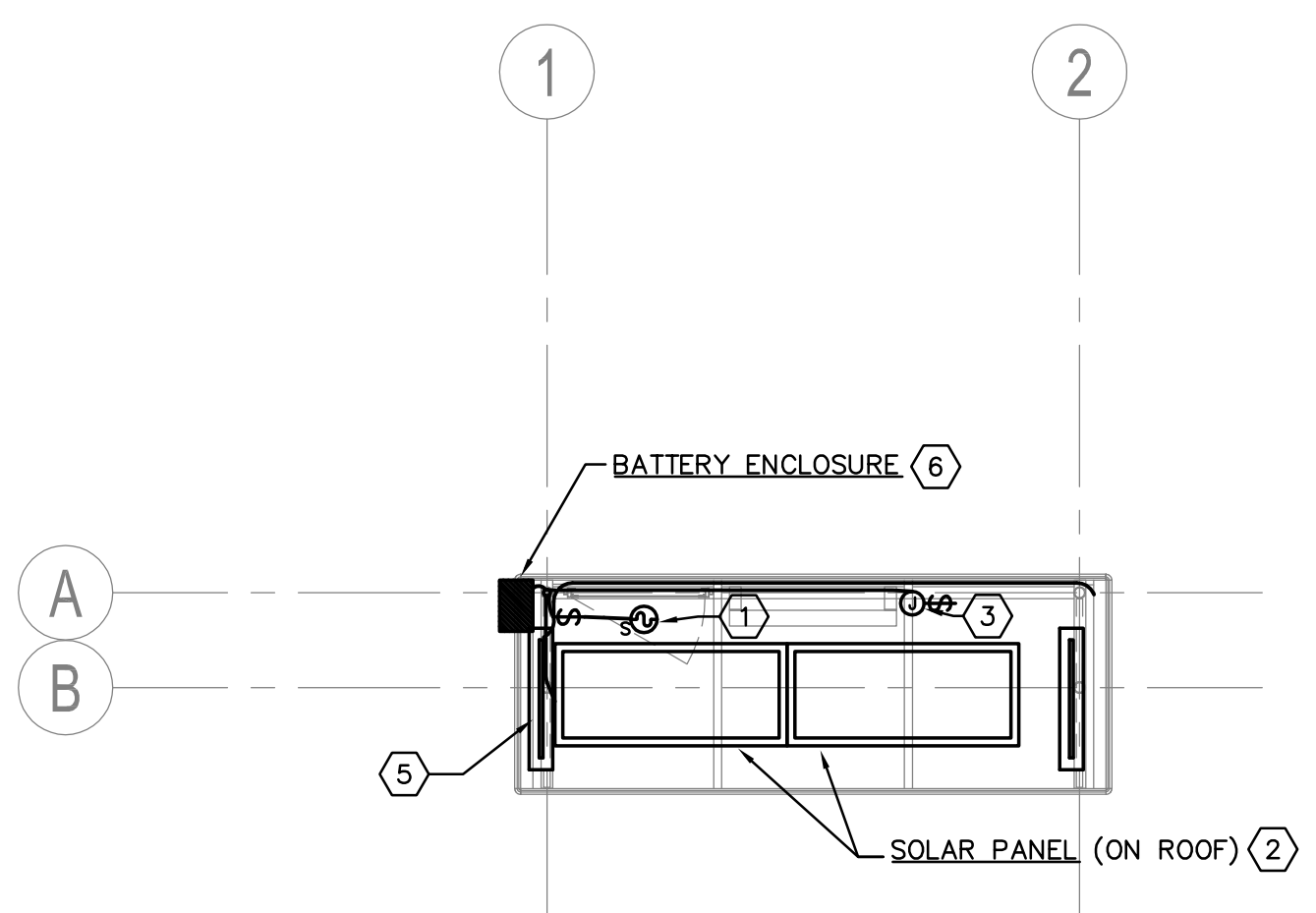

4 DUBLIN BASIC - PV
 SCALE: 1/4"=1'-0"

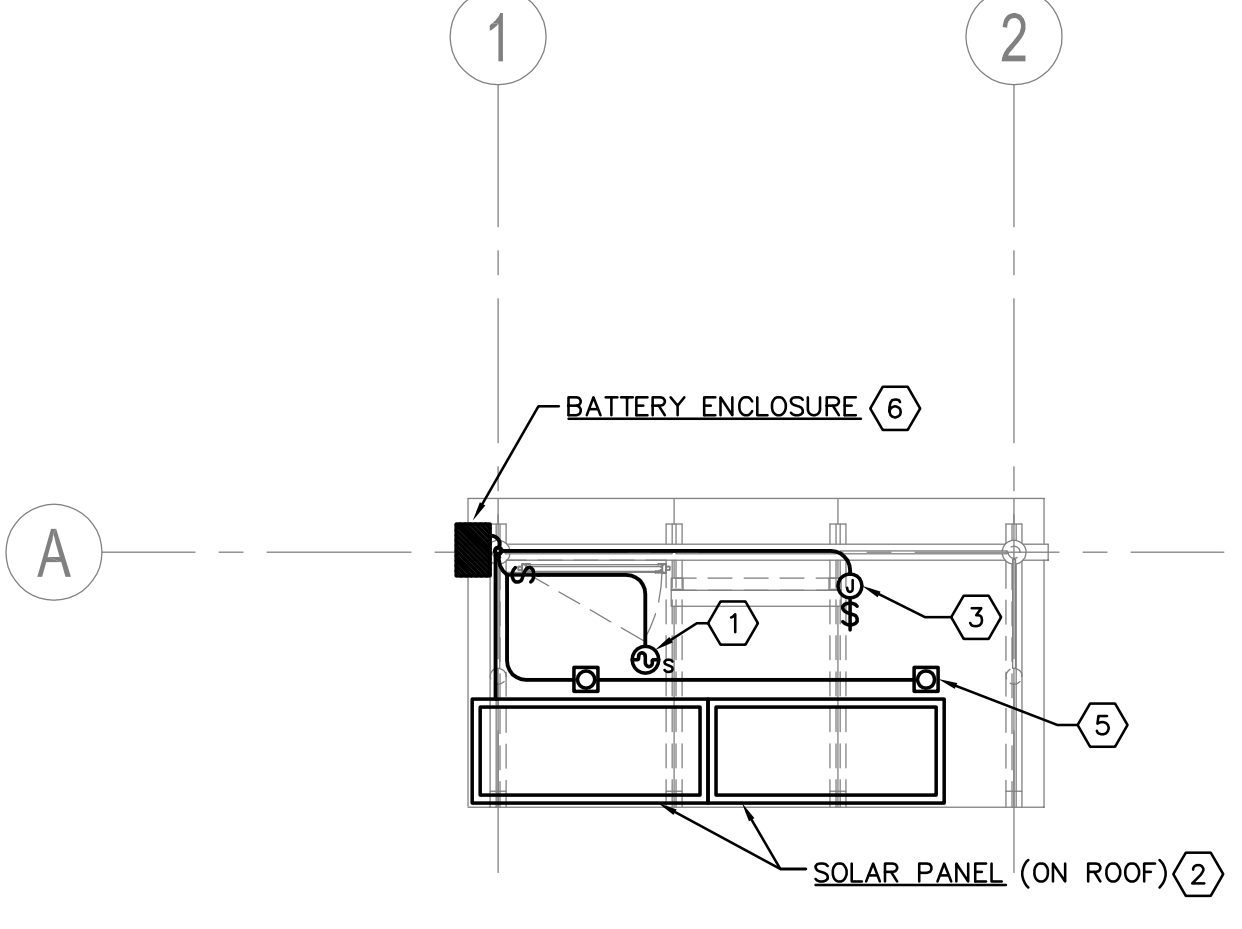

2 RAPID BASIC - PV
 SCALE: 1/4"=1'-0"

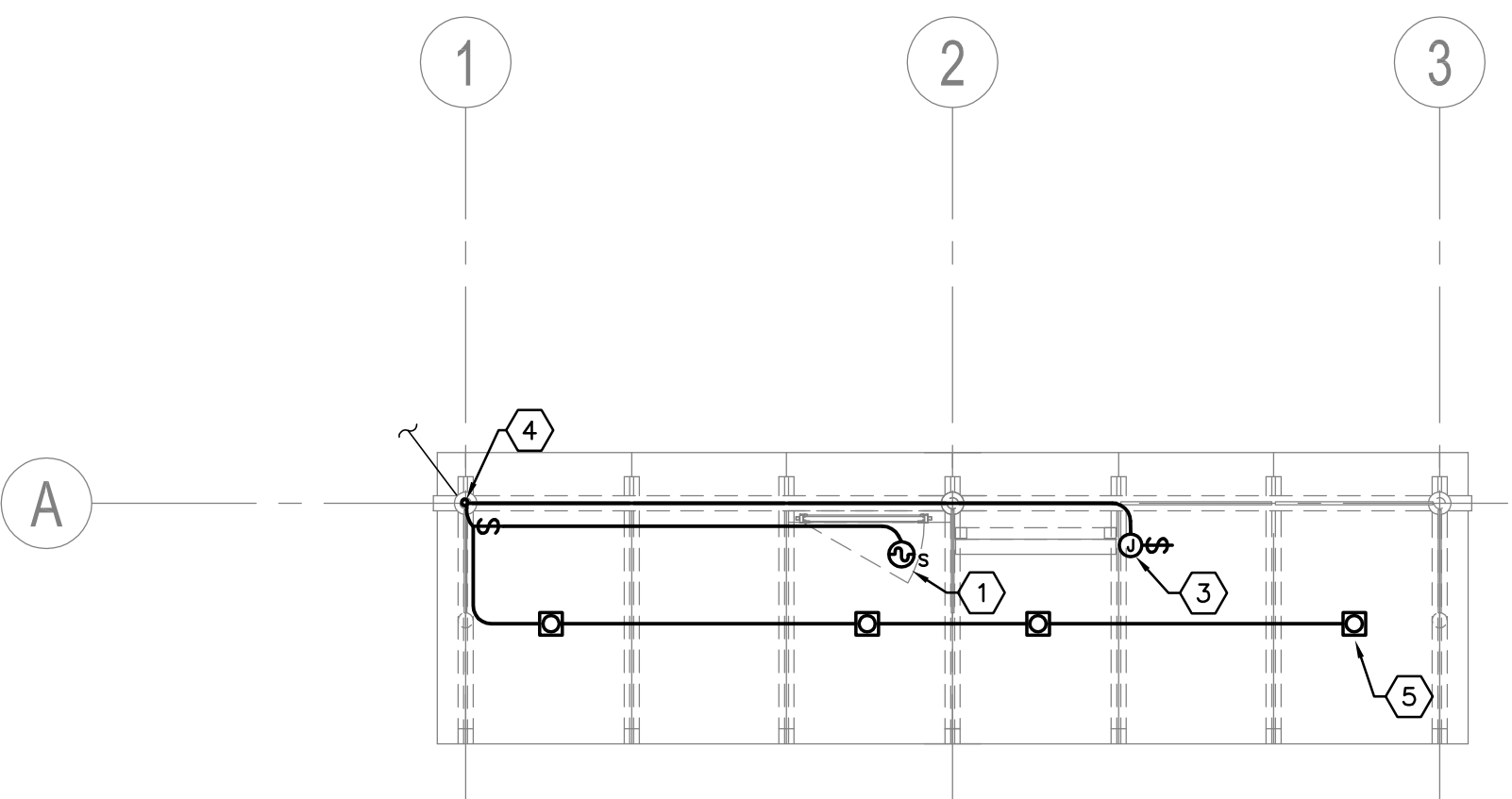

5 RAPID STANDARD - ELECTRICAL
 SCALE: 1/4"=1'-0"

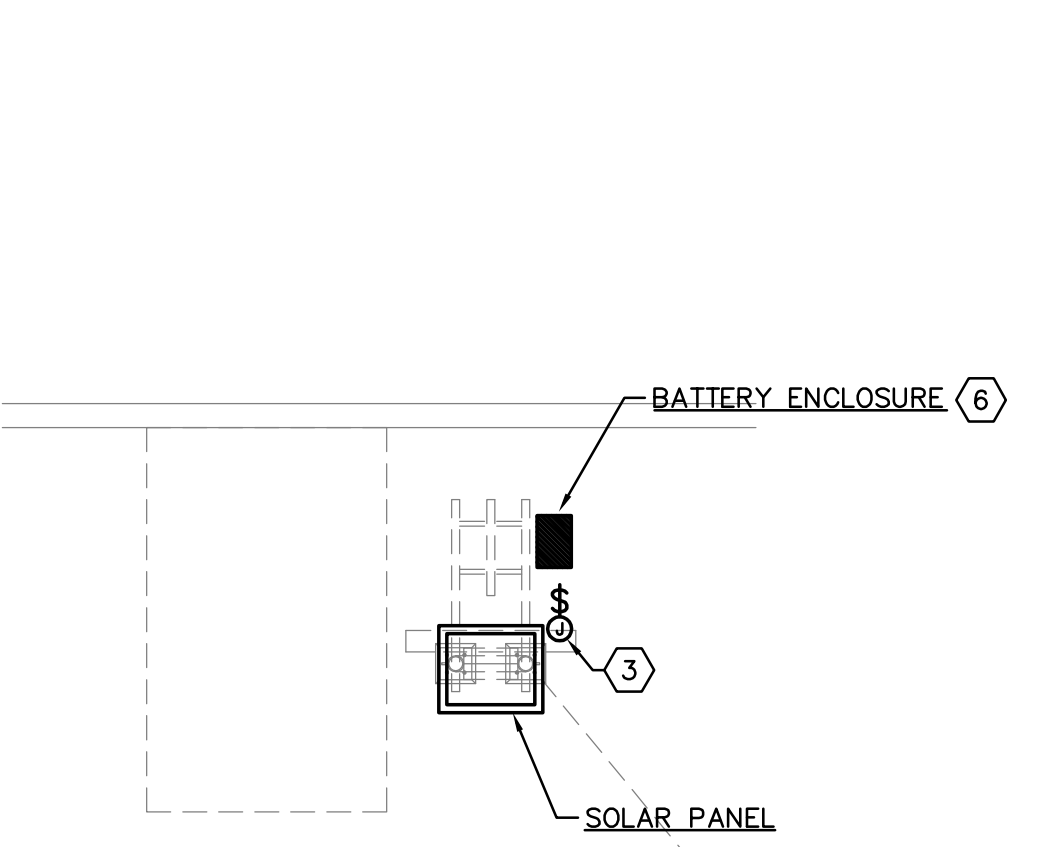

3 FLAG SIGNS - PV
 SCALE: 1/4"=1'-0"

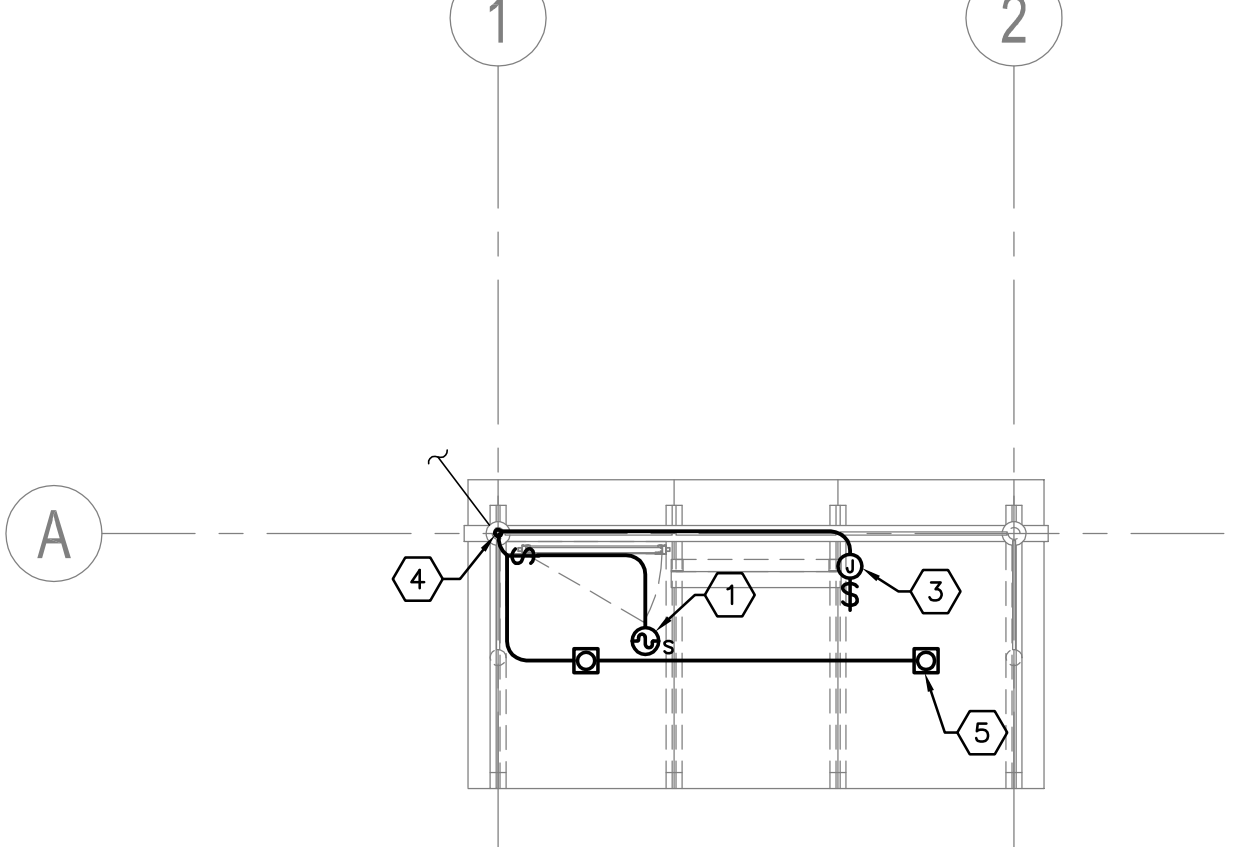

1 RAPID BASIC - ELECTRICAL
 SCALE: 1/4"=1'-0"

FILE INFO: T:\2008\2008-0581\Elec\Procurement\0581E110_Procurement.dwg
 XREFS:TBULK_Procurement\XPE_L-L-C\XRPC-L-BASIC; XGRD-BASIC; A114; XGRD-DUBLIN; XRPC-L-STANDARD; XGRD-STANDARD; A115; XGRD-DUBLIN-STANDARD; XGRD-STANDARD; XELEV-POLE PLOTTED: May 07, 2009 5:19pm BY: 1
 2
 C
 4

FURNISHINGS

Bid Item 6 – RAPID Pedestrian Bench

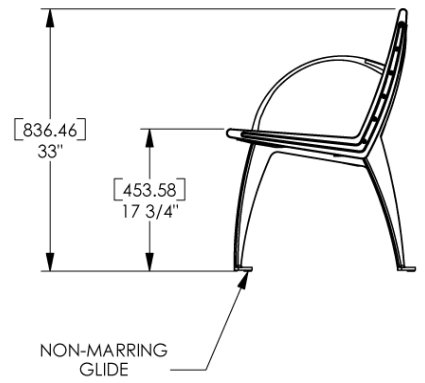
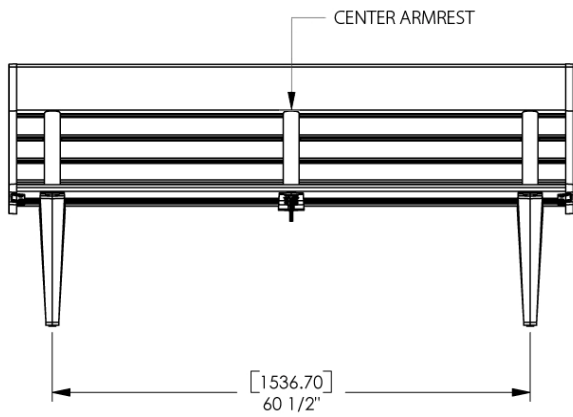
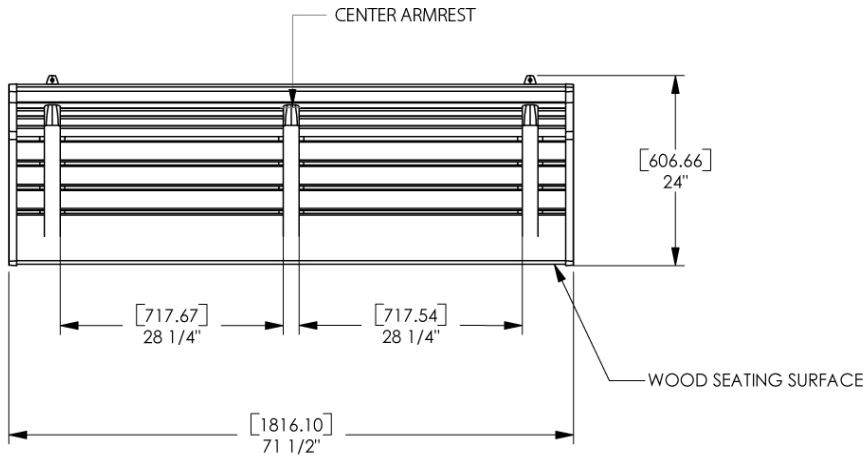

Bid Item 9-RAPID Pedestrian Light Pole and Luminaire

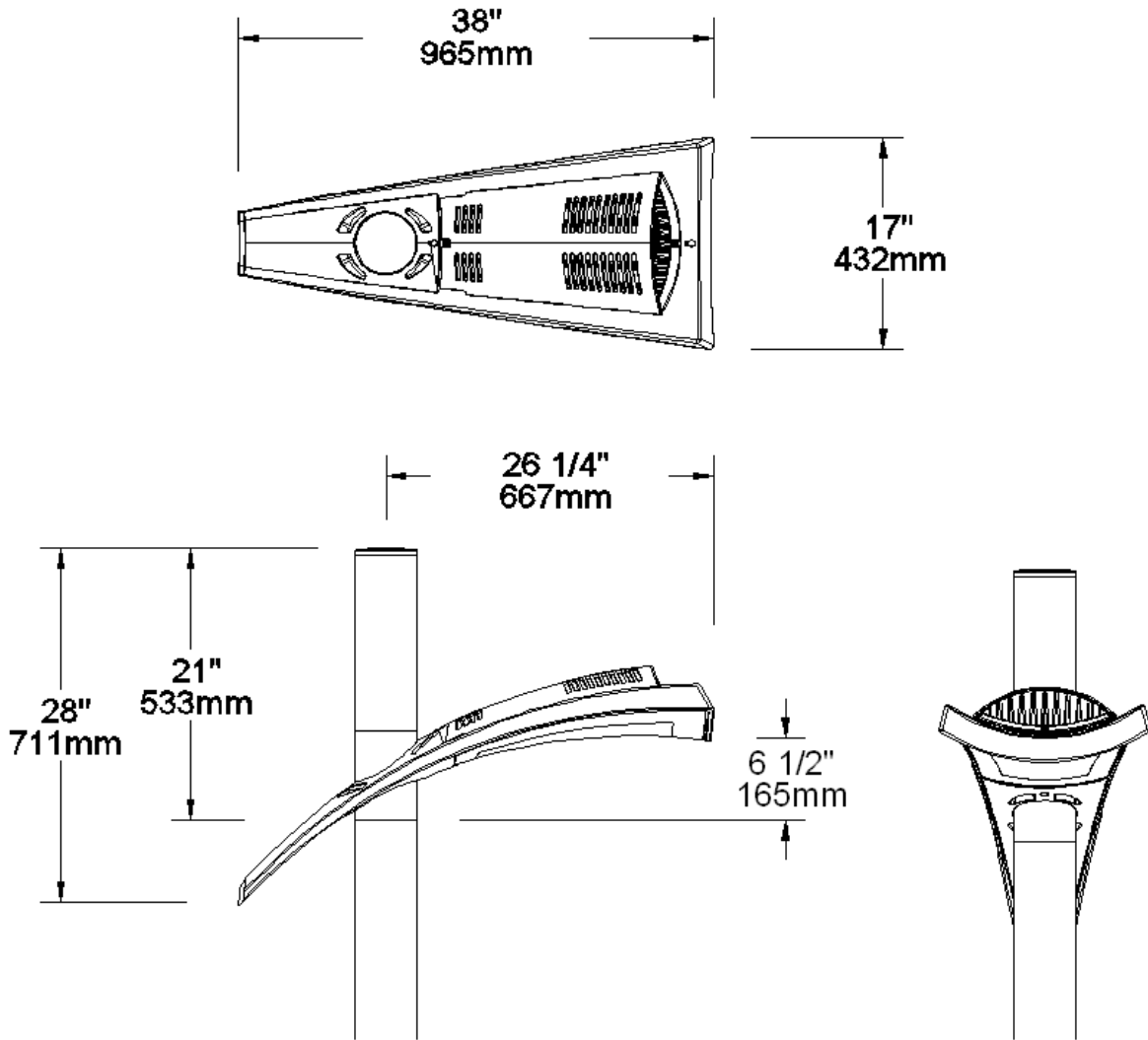

Bid Item 9-RAPID Pedestrian Light Pole and Luminaire

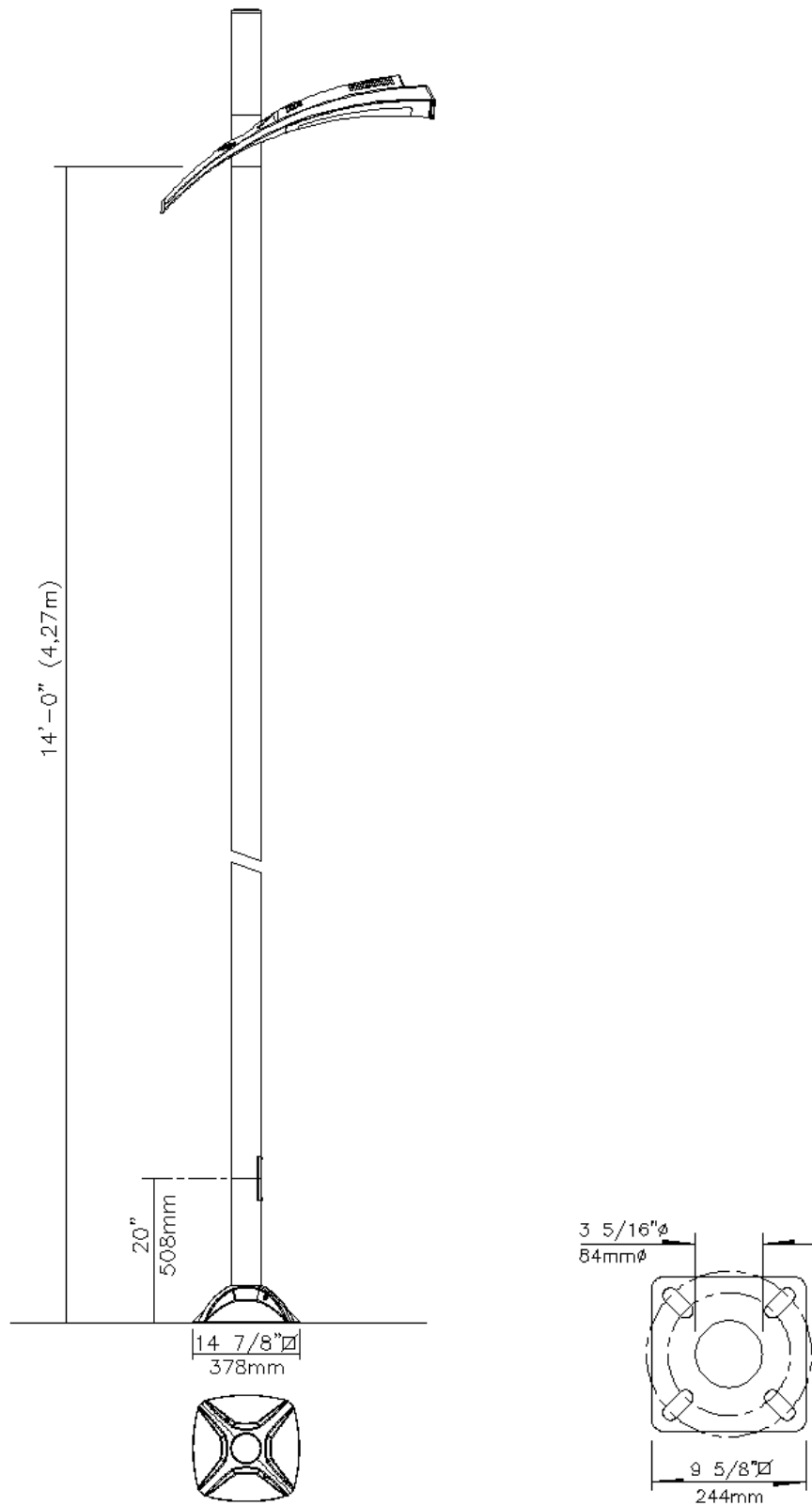

(This page intentionally left blank.)

BID FORMS

The Contractor shall furnish as part of this bid all of the information requested on the form. Failure to provide a price quotation on all items shown on the bid Form may result in rejection of the bid.

Pursuant to the Notice Inviting Bids, the undersigned Bidder submits a bid on the attached bid Forms and binds itself on award by the Livermore Amador Valley Transit Authority (LAVTA) under this bid to execute a Contract in accordance with its bid, the Contract Documents attached hereto and entitled "LAVTA Bus Shelter Demolition and Movement, [2017-17]", and to furnish the Bonds required by the Contract Documents. The components of the Contract Documents, namely, Notice Inviting Sealed Bids, General Conditions and Instructions for Bidders, Special Provisions, Technical Specifications, Bid Forms; Addenda, if any, and drawings, are made a part of this bid and all provisions contained therein are hereby accepted and all representations and warranties required thereby are hereby affirmed.

The bid prices below **exclude** any and all Federal taxes, and **exclude** California State sales tax or use taxes for Alameda County and applicable import duties, if any.

In addition, the bid prices below include all costs for labor, materials, tolls, equipment, services, warranty, bonding, insurance, shipment, delivery, overhead, profit and all other costs necessary to perform the work in accordance with the Contract Specifications. The bidder shall itemize the lump sum price to perform this work on this Bid Form Page B-3 and enter the Grand Total Bid Price at the bottom of Page B-1 below.

COMPANY NAME: _____

having examined the Contract Documents referred to hereinabove and all conditions affecting the work, hereby proposes and agrees to furnish all labor, materials, equipment and other services, including all costs and expenses associated herewith, which are necessary for completion of the work for:

**LAVTA Bus Shelter Demolition and Movement Project
2017-17**

The undersigned Bidder acknowledges receipt, understanding and full consideration of the following addenda to the Contract Documents:

ADDENDA NOs: (if none, so state): _____

GRAND TOTAL BID PRICE

Our price to perform the work required by this IFB is the lump sum Grand Total Bid Price below:

_____ dollars, \$_____.

ACKNOWLEDGEMENT OF TERMS AND CONDITIONS

Signing in the space below certifies that the subject Bidder has read, understood and will comply with all terms and conditions set forth in the General Conditions and Instructions for Bidders, Special Provisions and Technical Specifications of this Contract and that the signatory(ies) are authorized to execute and bind the Company to all terms and conditions of the Contract Documents

Name of Business Organization

Street Address

City

State

Zip Code

Type of Organization (Sole Owner, Partnership, Corporation*, etc.)

Signature

Title

Printed Name

Date

Signature*

Title

Printed Name

Date

(____) _____
Area Code Telephone Number

(____) _____
Area Code Facsimile Number

Contractor's License No.

License Classification

Expiration Date

Contractor's DIR Registration No.**

Expiration Date

****Bidders must submit proof of contractor registration with DIR (e.g. a hard copy of the relevant page of the DIR's database found at: <https://efiling.dir.ca.gov/PWCR/Search>).**

Are you registered with the California Board of Equalization? **YES*** ____ **No** ____

*If yes, please attach a copy of your registration.

***NOTE: If the Contractor is a corporation, two corporate officers must sign on behalf of the corporation as follows: (1) Chairman of the Board, President or Vice President; and, (2) the Secretary, Assistant Secretary, Chief Financial Officer, Assistant CFO, Treasurer or Assistant Treasurer. In the alternative, this Agreement may be executed by a single officer or a person other than an officer provided that evidence satisfactory to the District is provided demonstrating that such individual is authorized to bind the corporation (e.g. a copy of a certified resolution from the corporation's board or a copy of the corporation's by-laws)**

Item No.	Description	Quantity	Unit	Unit Cost	Cost
	Roadway				
1	Mobilization	1	LS	\$	\$
2	Contractor construction staking	1	LS	\$	\$
3	Encroachment Permits (Livermore and Pleasanton)	1	LS	\$	\$
4	City Inspections (Livermore and Pleasanton)	1	\$	\$ 10,000.00	\$ 10,000.00
5	Contractor-Hired Testing Agency	1	LS	\$	\$
6	Prepare water pollution control program	1	LS	\$	\$
7	Traffic control system	1	LS	\$	\$
8	Construction area signs	1	LS	\$	\$
9	Remove concrete sidewalk	308	SY	\$	\$
10	Remove and dispose of existing bus stop shelter	4	EA	\$	\$
11	Relocate rapid shelter (including foundations)	4	EA	\$	\$
12	Relocate rapid bench	12	EA	\$	\$
13	Relocate rapid trash/recycling receptacle set	4	EA	\$	\$
14	Relocate rapid column-mounted flag sign (including foundation)	4	EA	\$	\$
15	Relocate rapid pedestrian light (including foundation)	6	EA	\$	\$
16	Salvage rapid bike rack	5	EA	\$	\$
17	Salvage rapid wayfinding sign	2	EA	\$	\$
18	Clearing and grubbing	1	LS	\$	\$
19	Conform earthwork and grading	1	LS	\$	\$
20	Minor concrete (sidewalk)	415	SF	\$	\$
21	Minor concrete (platform)	1,773	SF	\$	\$
22	Install rapid pedestrian light (including foundation) (LAVTA furnished)	2	EA	\$	\$
23	Install rapid bike rack (LAVTA furnished)	8	EA	\$	\$
	Electrical				
24	Furnish and install No. 5 pull box	12	EA	\$	\$
25	Furnish and install 2" conduit	242	LF	\$	\$
26	Furnish and install conductor wire	1,500	LF	\$	\$
27	Furnish and install fuses and splicing	4	EA	\$	\$
28	Install salvaged standard electronic real-time information sign	4	EA	\$	\$
GRAND TOTAL BID PRICE					\$

(This page intentionally left blank)

BIDDER'S BOND

KNOW ALL PERSONS BY THESE PRESENTS:

That _____, as BIDDER, and _____, as Surety, are held and firmly bound unto the Livermore Amador Valley Transit Authority, ("AUTHORITY"), in the sum of \$ _____, **being at least ten percent of the total amount of the bid**, for the payment of which sum in lawful money of the United States of America to the AUTHORITY we bind ourselves, our heirs, executors, administrators, successors and assigns, jointly and severally, firmly by these presents.

The condition of the above obligation is such that, whereas the BIDDER has submitted said Bid to the AUTHORITY;

NOW, THEREFORE, if the BIDDER is awarded a Contract by AUTHORITY and, within the time and in the manner required by the Specifications, enters into a written Contract with AUTHORITY, and furnishes the requisite bond or bonds, then this obligation shall become null and void, otherwise to remain in full force and effect.

In the event suit is brought upon this bond by AUTHORITY and judgment is recovered, the Surety shall pay all costs incurred by AUTHORITY in such suit, including a reasonable attorneys' fee to be fixed by the Court.

The Surety shall be bound by any valid arbitration award among the parties.

California law shall govern the interpretation of this bond.

Dated: _____, 2017

TO BE CONSIDERED COMPLETE, BOTH THE BIDDER AND AN ADMITTED SURETY INSURER AUTHORIZED BY THE CALIFORNIA INSURANCE COMMISSIONER TO TRANSACT SURETY BUSINESS IN THE STATE OF CALIFORNIA, MUST SIGN THIS BIDDER'S BOND. IN ADDITION, THE SURETY'S SIGNATURE MUST BE NOTARIZED AND A COPY OF THE SURETY'S POWER OF ATTORNEY MUST BE ATTACHED.

Bidder's Name (Print)

Bidder's Signature

Surety's Name (Print)

Surety's Signature

Surety's Address

City State Zip

Notarized By: _____

Notary Stamp

(This page intentionally left blank)

SAMPLE IRREVOCABLE STANDBY LETTER OF CREDIT

NOTE: SAMPLE FORMAT ONLY. ORIGINAL LETTER MUST BE ON THE FINANCIAL INSTITUTION'S LETTERHEAD FROM WHICH IT IS DRAWN.

Date: _____

Livermore Amador Valley Transit Authority
1362 Rutan Court, Suite 100
Livermore, CA 94551

Re: Irrevocable Standby Letter of Credit No. ____

Executive Director:

We hereby issue in favor of the Livermore Amador Valley Transit Authority this Irrevocable Standby Letter of Credit for the account of _____, a (insert nature of organization, whether sole proprietorship, partnership, corporation, etc.), in the amount of XXXXXX Dollars, (\$000), which is available upon your demand when accompanied by a signed statement from an officer of the Livermore Amador Valley Transit Authority, stating that:

"The amount drafted is due to the Livermore Amador Valley Transit Authority because of the failure of to enter into a written Contract awarded to it by the AUTHORITY, or to furnish the requisite bond(s) or insurance certificates within the time and in the manner required by the Contract Documents and Specifications for [CONTRACT NAME, CONTRACT NUMBER]. We hereby agree with the drawers and/or bona fide holders that drafts drawn and negotiated in conformity with the terms of this Letter of Credit will be duly honored upon presentation when presented on or before _____, 2017. Partial drawings are permitted."

Except so far as otherwise expressly stated, this credit is subject to the Uniform Customs and Practice for Documentary Credits (2007 Revision) of the International Chamber of Commerce Publication No. 600.

Sincerely,

(Name of financial institution)

By: _____
(Signature)

Title: _____

(This page intentionally left blank)

LIST OF REFERENCES

(Do not use Livermore Amador Valley Transit Authority ("LAVTA") as a reference)

1. COMPANY NAME _____
STREET ADDRESS _____
CITY, STATE, ZIP _____
NAME OF PERSON
TO CONTACT _____
AREA CODE/PHONE # (_____) _____
VALUE OF WORK PERFORMED _____

2. COMPANY NAME _____
STREET ADDRESS _____
CITY, STATE, ZIP _____
NAME OF PERSON
TO CONTACT _____
AREA CODE/PHONE # (_____) _____
VALUE OF WORK PERFORMED _____

3. COMPANY NAME _____
STREET ADDRESS _____
CITY, STATE, ZIP _____
NAME OF PERSON
TO CONTACT _____
AREA CODE/PHONE # (_____) _____
VALUE OF WORK PERFORMED _____

LIST OF REFERENCES (Cont.)

4. COMPANY NAME _____
STREET ADDRESS _____
CITY, STATE, ZIP _____
NAME OF PERSON
TO CONTACT _____
AREA CODE/PHONE # (_____) _____
VALUE OF WORK PERFORMED _____

5. COMPANY NAME _____
STREET ADDRESS _____
CITY, STATE, ZIP _____
NAME OF PERSON
TO CONTACT _____
AREA CODE/PHONE # (_____) _____
VALUE OF WORK PERFORMED _____

**NONCOLLUSION DECLARATION TO BE EXECUTED BY BIDDER
AND SUBMITTED WITH BID**

The undersigned declares:

I am the _____ of _____, the party making the foregoing bid.

The bid is not made in the interest of, or on behalf of, any undisclosed person, partnership, company, association, organization, or corporation. The bid is genuine and not collusive or sham. The bidder has not directly or indirectly induced or solicited any other bidder to put in a false or sham bid. The bidder has not directly or indirectly colluded, conspired, connived, or agreed with any bidder or anyone else to put in a sham bid, or to refrain from bidding. The bidder has not in any manner, directly or indirectly, sought by agreement, communication, or conference with anyone to fix the bid price of the bidder or any other bidder, or to fix any overhead, profit, or cost element of the bid price, or of that of any other bidder. All statements contained in the bid are true. The bidder has not, directly or indirectly, submitted his or her bid price or any breakdown thereof, or the contents thereof, or divulged information or data relative thereto, to any corporation, partnership, company association, organization, bid depository, or to any member or agent thereof to effectuate a collusive or sham bid, and has not paid, and will not pay, any person or entity for such purpose.

Any person executing this declaration on behalf of a bidder that is a corporation, partnership, joint venture, limited liability company, limited liability partnership, or any other entity, hereby represents that he or she has full power to execute, and does execute, this declaration on behalf of the bidder.

I declare under penalty of perjury under the laws of the State of California that the foregoing is true and correct and that this declaration is executed on _____ [date], at _____ [city], _____ [state]."

Signature of Bidder

Title

Date

DISQUALIFICATION QUESTIONNAIRE

The Bidder shall complete, under penalty of perjury, the following questionnaire:

Has the Bidder, any officer of the Bidder, or any employee of the Bidder who has proprietary interest in the Bidder, ever been disqualified, removed, or otherwise prevented from Bidding on or completing a federal, state, or local government project because of a violation of law or a safety regulation?

Yes* _____ No _____

*If the answer is yes, explain the circumstances in the following space:

NOTE: This questionnaire constitutes a part of the Bid, and signature on any portion of this Bid shall constitute signature on this questionnaire.

IMPORTANT: USE A SEPARATE FORM FOR EACH SEPARATE SOLICITATION, PROVISION, OR SPECIFICATION ITEM REQUEST! COPY THIS FORM AS NEEDED.

Submitted by: _____ (Company Name)

The Authority requires that all prospective bidders completely fill out and attach this form **with every separate specification item request** for an Approved Equal pertaining to this Contract. Failure to completely fill out this form and submit with the request may result in denial of the request. Any further information that may be useful in reviewing such a request should also be attached to this form.

1. Approved equal is being requested for _____,
to be used in place of _____ (list technical specification or other reference number, [e.g. page TS-11, title, subsection, item]).
2. Description of approved equal request/substitution: _____

3. Product purpose: _____

4. Does this proposed approved equal request/substitution meet all applicable federal, state and local laws and regulations? _____ (If NO, please explain):

5. List three (3) commercial firms within the United States, which have used the proposed approved equal request/substitution (list California properties first):
 - A. Company Name _____
Street Address _____
City/State/Zip Code _____
Area Code/Telephone No. (_____) _____
Name of Contact Person _____
 - B. Company Name _____
Street Address _____
City/State/Zip Code _____
Area Code/Telephone No. (_____) _____
Name of Contact Person _____
 - C. Company Name _____
Street Address _____
City/State/Zip Code _____
Area Code/Telephone No. (_____) _____
Name of Contact Person _____
6. List the benefits and any other reasons why the Authority should approve this request for approved equal/substitution:

7. **Attach pertinent test data, technical data and background information on the approved equal/substitution request.**

(this page intentionally left blank)

**DISADVANTAGED BUSINESS ENTERPRISE (DBE)
QUESTIONNAIRE**

1. **Is your firm a registered Disadvantaged Business Enterprise (DBE)?**

Yes _____ No _____

If the answer is "**Yes**", please fill in your DBE Certification Number: _____

2. **Does your firm plan to subcontract any of the work or services or procure items required under this contract to any subcontractors, subconsultants, or suppliers?**

Yes _____ No _____

If the answer is "**No**", you may stop here and you do not need to continue to Question 3. Please sign and submit this page.

3. **Describe briefly how your firm solicited small businesses, including DBEs, to participate on this contract.**

4. **Explain whether your firm considered selecting portions of the work that are economically feasible for small businesses, including DBEs, to perform. Identify the portion(s) of the work or service that was selected for subcontracting and explain why these portions of work were selected:**

5. **Explain the reasons for rejecting bids and accepting the bids from the selected subcontractor, subconsultant or supplier:**

6. Describe any efforts your firm made to assist small businesses, including DBEs, in obtaining (1) adequate information about this solicitation, and (2) necessary equipment, supplies, bonding, or insurance, among others, to perform this contract:

7. Describe any other steps your firm used to encourage or select small businesses, including DBEs:

The undersigned certifies that the above narrative is true and accurate and may be relied upon by the Agencies in evaluating the Bidder/Proposer's compliance with the bidding/proposal requirements.

Signature of Owner or Authorized Representative

Title

Date

Designation of Subcontractors and Sub-bidders

Bidder's Name: _____ Is your firm a Disadvantaged Business Enterprise: Yes _____ No _____
 Address: _____ Firm's Annual Gross Receipts: _____ Age of Firm: _____
 Phone: () _____ Fax: () _____

Bidder is required to furnish the following information in accordance with the provisions of Sections 4100 to 4114, inclusive, of the Public Contract Code of the State of California and Authority sub-bid reporting requirements.

Instructions: (1) Bidder is required to furnish the following information on all subcontractors that will perform work, provide labor or render services in in an amount in excess of .5% of the total contract price pursuant to Sections 4100 to 4114, inclusive, of the Public Contract Code of the State of California and Authority sub-bid reporting requirements.
 (2) In addition, Bidder MUST provide information below for ALL subcontractors/subconsultants/suppliers ("sub-bidders") that provided Bidder a bid, quote, or proposal for work, services or supplies associated with this contract. This information shall be provided for all sub-bidders regardless of tier for both DBEs and non-DBEs alike. Include all bid acceptance(s) AND rejection(s). Signature is required on page two of this form.

#	Subcontractor/Subconsultant/Supplier Firm Name/Address/Phone/Fax/Contact Person	Contractor's License No.	Contractor's DIR Registration No.	DBE (Yes/No)	Portion of Work/Bid Item No. or Type of Materials/Supplies	Dollar Amount of Work/Supplies	Bid/Quote Accepted (Yes/No)
1							
2							
3							
4							
5							

Note: Do not indicate more than one "Yes" in the column "Bid/Quote Accepted" for alternative subcontractors for the same work. Use additional sheets if necessary.

Designation of Subcontractors and Sub-bidders (Continued)

	Subcontractor/Subconsultant/Supplier Firm Name/Address/Phone/Fax/Contact Person	Contractor's License No.	Contractor's DIR Registration No.	DBE (Yes/No)	Portion of Work/Bid Item No. or Type of Materials/Supplies	Dollar Amount of Work/Supplies	Bid/Quote Accepted (Yes/No)
6							
7							
8							
9							
10							

Note: Do not indicate more than one "Yes" in the column "Bid/Quote Accepted" for alternative subcontractors for the same work. Use additional sheets if necessary.

The undersigned will enter into a formal agreement with the subcontractor(s), subconsultant(s) and/or supplier(s) whose bid/quote was accepted conditioned upon execution of a contract with the LAVTA. The undersigned certifies that any DBE listed whose quote was accepted will be performing a commercially useful function on the contract. I certify under penalty of perjury that the information included on this form is accurate and true.

Signature of Owner or Authorized Representative

Date

LOBBYING CERTIFICATION FOR CONTRACTS GRANTS, LOANS AND COOPERATIVE AGREEMENTS (Pursuant to 49 CFR Part 20, Appendix A)

The undersigned certifies, to the best of his or her knowledge and belief, that:

1. No Federal appropriated funds have been paid or will be paid, by or on behalf of the undersigned, to any person for influencing or attempting to influence an officer or employee of an agency, a Member of Congress, an officer or employee of Congress, or an employee of a Member of Congress in connection with the awarding of any Federal Contract, the making of any Federal grant, the making of any Federal loan, the entering into of any cooperative agreement, and the extension, continuation, renewal, amendment, or modification of any Federal Contract, grant, loan, or cooperative agreement.
2. If any funds other than Federal appropriated funds have been paid or will be paid to any person for making lobbying contacts to an officer or employee of any agency, a Member of Congress, an officer or employee of Congress, or an employee of a Member of Congress in connection with this Federal Contract, grant, loan, or cooperative agreement, the undersigned shall complete and submit Standard Form--LLL, "Disclosure Form to Report Lobbying," in accordance with its instructions and as amended by "Government wide Guidance for New Restrictions on Lobbying," 61 Fed. Reg. 1413 (1/19/96).
3. The undersigned shall require that the language of this certification be included in the award documents for all subawards at all tiers (including subcontracts, subgrants, and Contracts under grants, loans, and cooperative agreements) and that all subrecipients shall certify and disclose accordingly.

This certification is a material representation of fact upon which reliance was placed when this transaction was made or entered into. Submission of this certification is a prerequisite for making or entering into this transaction imposed by 31 U.S.C. § 1352 (as amended by the Lobbying Disclosure Act of 1995). Any person who fails to file the required certification shall be subject to a civil penalty of not less than \$10,000 and not more than \$100,000 for each such failure.

The Bidder, _____, certifies or affirms the truthfulness and accuracy of each statement of its certification and disclosure, if any. In addition, the Bidder understands and agrees that the provisions of 31 U.S.C. A 3801, et. seq. apply to this certification and disclosure, if any.

_____ Signature of Authorized Official

_____ Name and Title of Authorized Official

_____ Date

DISCLOSURE OF LOBBYING ACTIVITIES		
Complete this form to disclose lobbying activities pursuant to 31 U.S.C. 1352		
<p>1. Type of Federal Action:</p> <p>a. contract b. grant c. cooperative agreement d. loan e. loan guarantee f. loan insurance</p>	<p>2. Status of Federal Action:</p> <p>a. bid/offer/application b. initial award c. post-award</p>	<p>3. Report Type:</p> <p>a. initial filing b. material change</p> <p>For Material Change Only: Year _____ Quarter _____ Date of last report: _____</p>
<p>4. Name and Address of Reporting Entity:</p> <p><input type="checkbox"/> Prime <input type="checkbox"/> Subawardee Tier, if known: _____</p> <p>Congressional District, if known: _____</p>	<p>5. If Reporting Entity in No. 4 is Subawardee, Enter Name and Address of Prime:</p> <p>Congressional District, if known: _____</p>	
<p>6. Federal Department/Agency:</p>	<p>7. Federal Program Name/Description:</p> <p>CFDA Number, if applicable: _____</p>	
<p>8. Federal Action Number, if known: _____</p>	<p>9. Award Amount, if known: \$ _____</p>	
<p>10.a. Name and Address of Lobbying Entity (if individual, last name, first name, MI):</p>	<p>10.b. Individuals Performing Services (including address if different from No. 10a) (last name, first name, MI):</p>	
<i>(Attach Continuation Sheet(s), if necessary)</i>		
<p>11. Amount of Payment (check all that apply):</p> <p>\$ _____ <input type="checkbox"/> actual <input type="checkbox"/> planned</p>	<p>13. Type of Payment (check all that apply):</p> <p><input type="checkbox"/> a. retainer <input type="checkbox"/> b. one-time fee <input type="checkbox"/> c. commission <input type="checkbox"/> d. contingent fee <input type="checkbox"/> e. deferred <input type="checkbox"/> f. other; specify _____</p>	
<p>12. Form of Payment (check all that apply):</p> <p><input type="checkbox"/> a. cash <input type="checkbox"/> b. in-kind; specify: nature _____ value _____</p>		
<p>14. Brief Description of Services Performed or to be Performed and Date(s) of Service, including officer(s), employee(s), or Member(s) contacted, for Payment indicated in Item 11:</p>		
<i>(Attach Continuation Sheet(s), if necessary)</i>		
<p>15. Continuation Sheet(s) SF-LLL-A attached: <input type="checkbox"/> Yes <input type="checkbox"/> No</p>		
<p>16. Information requested through this form is authorized by title 31 U.S.C. section 1352. This disclosure of lobbying activities is a material representation of fact upon which reference was placed by the user above when this transaction was made or entered into. This disclosure is required pursuant to 31 U.S.C. 1352. This information will be reported to the Congress semi-annually and will be available for public inspection. Any person who fails to file the required disclosure shall be subject to a civil penalty of not less than \$10,000 and not more than \$100,000 for each failure.</p>	<p>Signature: _____</p> <p>Print Name: _____</p> <p>Title: _____</p> <p>Telephone No. _____ Date: _____</p>	

DISCLOSURE OF LOBBYING ACTIVITIES
CONTINUATION SHEET

Reporting Entity: _____ Page _____ of _____

Authorized for Local Reproduction
Standard Form – LLL-A
BILLING CODES 3410-01-C; 6450-01-C; 6690-01-C;
8025-01C; 7510-01-C; 3510-FE-C; 8120-01-C; 4710-24-
C; 6116-01-C; 6051-01-C; 8230-01-C; 3210-01-C; 4210-
32-C; 4410-18-C; 4510-23-C; 4810-25-C; 3001-01-C;
4000-01-C; 3820-01-C; 6560-50-C; 6820-61-C; 4310-RF-
C; 6718-01-C; 4150-04-C; 7555-01-C; 7537-01-C; 7536-
01-C; 6050-28-C; 4910-62-C

INSTRUCTIONS FOR COMPLETION OF SF-LLL, DISCLOSURE OF LOBBYING ACTIVITIES

This disclosure form shall be completed by the reporting entity, whether subawardee or prime Federal recipient, at the initiation or receipt of a covered Federal action, or a material change to a previous filing pursuant to title 31 U.S.C. section 1352. The filing of a form is required for each payment or agreement to make payment to any lobbying entity for influencing or attempting to influence an officer or employee of any agency, a Member of Congress, an officer or employee of Congress, or an employee of a Member of Congress in connection with a covered Federal action. Use the SF-LLL-A Continuation Sheet for additional information if the space on the form is inadequate. Complete all items that apply for both the initial filing and material change report. Refer to the implementing guidance published by the Office of Management and Budget for additional information.

1. Identify the type of covered Federal action for which lobbying activity is and/or has been secured to influence the outcome of a covered Federal action.
2. Identify the status of the covered Federal action.
3. Identify the appropriate classification of this report. If this is a follow-up report caused by a material change to the information previously reported, enter the year and quarter in which the change occurred. Enter the date of the last previously submitted report by this reporting entity for this covered Federal action.
4. Enter the full name, address, city, state and zip code of the reporting entity. Include Congressional District, if known. Check the appropriate classification of the reporting entity that designates if it is, or expects to be a prime or subaward recipient. Identify the tier of the subawardee, e.g., the first subawardee of the prime is the 1st tier. Subawards include but are not limited to subcontracts, subgrants and contract awards under grants.
5. If the organization filing the report in item 4 checks "Subawardee", then enter the full name, address, city, state and zip code of the prime Federal recipient. Include Congressional District, if known.
6. Enter the name of the Federal agency making the award or loan commitment. Include at least one organizational level below agency name, if known. For example, Department of Transportation, United States Coast Guard.
7. Enter the Federal program name or description for the covered Federal action (item 1). If known, enter the full Catalog of Federal Domestic Assistance (CFDA) number for grants, cooperative agreements, loans, and loan commitments.
8. Enter the most appropriate Federal identifying number available for the Federal action identified in item 1 (e.g., Request for Proposal (RFP) number; Invitation for Bid (IFB) number; grant announcement number; the contract, grant, or loan award number; the application/proposal control number assigned by the Federal agency). Include prefixes, e.g., "RFP-DE-90-001."
9. For a covered Federal action where there has been an award or loan commitment by the Federal agency, enter the Federal amount of the award/loan commitment for the prime entity identified in item 4 or 5.
10. (a) Enter the full name, address, city, state and zip code of the lobbying entity engaged by the reporting entity identified in item 4 to influence the covered Federal action.
(b) Enter the full names of the individual(s) performing services, and include full address if different from 10 (a).
Enter Last Name, First Name, and Middle Initial(MI).
11. Enter the amount of compensation paid or reasonably expected to be paid by the reporting entity (item 4) to the lobbying entity (item 10). Indicate whether the payment has been made (actual) or will be made (planned). Check all boxes that apply. If this is a material change report, enter the cumulative amount of payment made or planned to be made.
12. Check the appropriate box(es). Check all boxes that apply. If payment is made through an in-kind contribution, specify the nature and value of the in-kind payment.
13. Check the appropriate box(es). Check all boxes that apply. If other, specify nature.
14. Provide a specific and detailed description of the services that the lobbyist has performed, or will be expected to perform, and the date(s) of any services rendered. Include all preparatory and related activity, not just time spent in actual contact with Federal officials. Identify the Federal official(s) or employee(s) contacted or the officer(s), employee(s), or Member(s) of Congress that were contacted.
15. Check whether or not a SF-LLL-A Continuation Sheet(s) is attached.
16. The certifying official shall sign and date the form, print his/her name, title, and telephone number.

Public reporting burden for this collection of information is estimated to average 30 minutes per response, including time for reviewing instructions, searching existing data sources, gathering and maintaining the data needed and completing and reviewing the collection of information. Send comments regarding the burden estimate or any other aspect of this collection of information, including suggestions for reducing this burden, to the Office of Management and Budget, Paperwork Reduction Project (0348-0046), Washington, D.C. 20503.

**BUY AMERICA CERTIFICATE
(Steel, Iron or Manufactured Products)**

SELECT AND COMPLETE ONLY ONE OF THE FOLLOWING CERTIFICATIONS:

Certificate of Compliance with 49 U.S.C. 5323(j)(1)

The bidder or offeror hereby certifies that it will meet the requirements of 49 U.S.C. 5323(j)(1), and the applicable regulations in 49 CFR Part 661.

Date _____

Signature _____

Company _____

Name _____

Title _____

Certificate of Non-Compliance with 49 U.S.C. 5323(j)(1)

The bidder or offeror hereby certifies that it cannot comply with the requirements of 49 U.S.C. 5323(j)(1) and 49 CFR Part 661.5, but it may qualify for an exception pursuant to 49 U.S.C. 5323(j)(2)(A), 5323(j)(2)(B), or 5325(j)(2)(D), and 49 CFR 661.7.

Date _____

Signature _____

Company _____

Name _____

Title _____

(This page intentionally left blank)

This Agreement, made and entered into this _____ day of _____, 2017 by and between _____, hereinafter called "Contractor" and the Livermore Amador Valley Transit Authority, hereinafter called "Authority."

WITNESSETH, that the Contractor and the Authority, for consideration hereinafter named, agree as follows:

1. **SCOPE OF WORK**

The Contractor shall perform all work and furnish all the labor, materials, tools, equipment, services and incidentals required under the Contract, in full accordance with the plans and specifications approved by the Authority entitled:

CONTRACT DOCUMENTS

FOR:

BUS SHELTER DEMOLITION AND MOVEMENT PROJECT
2017-17

dated _____, 2017, and which are appended hereto and made part of this Agreement.

2. **TERM OF CONTRACT**

The Contractor shall complete all work under the Contract Documents within 90 calendar days of the Notice to Proceed. After the Contract has been executed by the parties, the CONTRACTOR shall begin work within one (1) calendar day after the effective date of the Notice to Proceed, and shall diligently prosecute all of the work under this Contract in all parts and requirements as defined in the Contract Documents, from the effective date of said Notice to Proceed.

3. **CONTRACT PRICE**

The Contractor shall faithfully perform the work required in the documents for the lump sum amount shown on the bid documents. Payments shall be made to the Contractor at the time and in the manner provided in the Contract Specifications.

4. **INDEPENDENT CONTRACTOR STATUS**

- A. The Contractor shall independently perform all Work required by the Contract Documents and shall not be considered as an agent or employee of the Authority, nor shall the Contractor's Subcontractors or employees be considered as subagents of the Authority.
- B. The Contractor and the Contractor's Subcontractors shall be licensed as required by the contract documents, in accordance with the laws of the State of California.

5. COMPONENT PARTS

This Contract shall consist of the following documents, each of which is on file in the office of the Authority and all of which are incorporated herein and made a part hereof by reference thereto:

- a. This Agreement
- b. Notice Inviting Sealed Bids
- c. Bid (as accepted by Authority)
- d. General Conditions and Instructions for Bidders
- e. Special Provisions
- f. Approved Equals, if any
- g. Technical Specifications and drawings
- h. Addenda (if any)
- i. Certificates of Insurance
- j. Performance and Payment Bonds

6. SERVICE OF NOTICE

Any notice required or permitted to be given by this Agreement shall be deemed given when personally delivered to recipient thereof or mailed by registered or certified mail, return receipt requested, postage prepaid, to the appropriate recipient thereof, in the case of the Contractor, at the business address specified in its bid and in the case of the Authority at the Livermore Amador Valley Transit Authority Administrative Offices, 1362 Rutan Court, Suite 100, Livermore, CA 94551, or at any other address which either party may subsequently designate in writing to other party.

7. GOVERNING LAW

This Contract shall be governed and construed in accordance with the laws of the State of California.

IN WITNESS WHEREOF, Authority has caused these presents to be executed by the Authority's officer thereunto duly authorized, and Contractor has subscribed same, all on the day and year first above written.

FOR THE CONTRACTOR:

Name under which business is conducted:

Business Address: _____

State _____ Zip Code _____ Telephone (____) _____

Type of business organization:

*If a Corporation (**see footnote**), incorporated under the laws of the State of:

The undersigned certify that they sign this Contract with full and proper authorization to do so.

By: _____ Print _____ Title: _____

By:* _____ Print _____ Title: _____

LIVERMORE AMADOR VALLEY TRANSIT AUTHORITY:

By: _____
Executive Director

APPROVED AS TO FORM:

By: _____
Attorney for the AUTHORITY

*If the Contractor is a Corporation, this Agreement *must be executed by two corporate officers*, consisting of:
(1) the President, Vice President, or Chair of the Board, *and*
(2) the Secretary, Assistant Secretary, Chief Financial Officer, Assistant CFO, Treasurer or Assistant Treasurer.
Alternatively, this Agreement may be executed by a single officer or a person other than an officer provided that evidence satisfactory to the Authority is provided demonstrating that such an individual is authorized to bind the corporation (e.g. a copy of a certified resolution from the corporation's board or a copy of the corporation's bylaws).

(this page intentionally left blank)

Sample Agreement

PERFORMANCE BOND

KNOW ALL PERSONS BY THESE PRESENTS, that

WHEREAS the **LIVERMORE/AMADOR VALLEY TRANSIT AUTHORITY**, hereinafter designated as "LAVTA," has awarded to _____, hereinafter designated as the "Principal," a Contract for _____; and

WHEREAS, said Principal is required under the terms of said Contract and the Specifications therefore to furnish a bond of faithful performance of said Contract,

NOW, THEREFORE, we, the Principal, and _____, as a California-admitted Surety, are held and firmly bound unto the said LAVTA in the penal sum of _____, being a sum equal to the total amount payable under the Contract, for the payment of which sum, well and truly to be made, we bind ourselves, our heirs, executors, administrators and successors, jointly and severally, firmly by these presents.

THE CONDITION OF THIS OBLIGATION IS SUCH, that if the above-bound Principal, or its heirs, executors, administrators, successors, or assigns approved by LAVTA, shall promptly and faithfully perform the covenants, conditions and agreements in the Contract during the original term and any extensions thereof as may be granted by LAVTA, with or without notice to Surety, and during the period of any guarantees or warranties required under the Contract, and shall also promptly and faithfully perform all the covenants, conditions, and agreements of any alteration of the Contract made as therein provided, notice of which alterations to Surety being hereby waived, on Principal's part to be kept and performed at the time and in the manner therein specified, and in all respects according to their true intent and meaning, and shall indemnify, defend, protect, and hold harmless LAVTA as stipulated in the Contract, then this obligation shall become and be null and void; otherwise it shall be and remain in full force and effect.

No extension of time, change, alteration, modification, or addition to the Contract, or of the work required thereunder, shall release or exonerate Surety on this bond or in any way affect the obligation of this bond; and Surety does hereby waive notice of any such extension of time, change, alteration, modification, or addition.

Whenever Principal shall be and declared by LAVTA to be in default under the Contract, Surety shall promptly remedy the default, or shall promptly do one of the following at LAVTA's election:

1. Undertake through its agents or independent contractors, reasonably acceptable to LAVTA, to complete the Contract in accordance with its terms and conditions and to pay and perform all obligations of Principal under the Contract, including without limitation, all obligations with respect to warranties, guarantees, and the payment of liquidated damages.
2. Reimburse LAVTA for all costs LAVTA incurs in completing the Contract, and in correcting, repairing or replacing any defects in materials or workmanship and/or materials and workmanship which do not conform to the specifications in the Contract.

Surety's obligations hereunder are independent of the obligations of any other surety for the performance of the Contract, and suit may be brought against Surety and such other sureties, jointly and severally, or against any one or more of them, or against less than all of them without impairing LAVTA'S rights against the others.

No right of action shall accrue on this bond to or for the use of any person or corporation other than LAVTA or its successors or assigns.

In the event suit is brought upon this bond by LAVTA, Surety shall pay reasonable attorney's fees and costs incurred by LAVTA in such suit.

IN WITNESS WHEREOF, the above bounded parties have executed this instrument under their seals this _____ day of _____, 20__, the name and corporate seal of each corporate party being hereto affixed and these presents duly signed by its undersigned representative, pursuant to authority of its governing body.

Principal

By: _____

By: _____

Surety

Address of Surety

Note: To be signed by Principal and Surety and signature of individual signing for Surety shall be notarized and evidence of power of attorney attached.

PAYMENT BOND

KNOW ALL PERSONS BY THESE PRESENTS, that _____ called the PRINCIPAL, and _____ a corporation duly organized under the laws of the State of _____, having its principal place of business at _____ in the State of _____, and authorized to do business in the State of California, hereinafter called the SURETY, are held and firmly bound unto the Livermore Amador Valley Transit Authority, hereinafter called the OBLIGEE, or order in the sum of _____ (\$ _____ .00) lawful money of the United States, for the payment of which, well and truly to be made, we bind ourselves, our heirs, executors, administrators and successors, jointly and severally, firmly by these presents.

THE CONDITION OF THIS OBLIGATION IS SUCH THAT:

WHEREAS, the PRINCIPAL has entered into a Contract with the OBLIGEE for _____ and said PRINCIPAL is required under the terms of said Contract to furnish a bond securing payment of claims to which reference is made in Section 3248 of the Civil Code.

NOW, THEREFORE, if said PRINCIPAL or any of its subcontractors fails to pay any of the persons named in Section 9100 of the Civil Code, or amounts due under the Unemployment Insurance Code with respect to work or labor performed under the Contract, or any amounts required to be deducted, withheld and paid over to the Employment Development Department from the wages of employees of the Contractor and his subcontractors pursuant to Section 13020 of the Unemployment Insurance Code with respect to such work and labor, the SURETY, will pay for the same, in an amount not exceeding the sum specified in this bond, and also will pay, in case suit is brought upon this bond, a reasonable attorney's fee, to be fixed by the court.

This bond will inure to the benefit of any of the persons named in Section 9100 of the Civil Code so as to give a right of action to such persons or their assigns in any suit brought upon this bond.

This bond is given to comply with Sections 9550 and 9554 of the Civil Code. The liability of the PRINCIPAL and SURETY hereunder is governed by the provisions of said Code, all acts amendatory thereof, and all other statutes referred to therein, including Section 8152 of the Civil Code.

SURETY, for value received, hereby agrees that no change, extension of time, alteration or addition to the terms of the Contract or to the work to be performed thereunder or to the Contract Documents accompanying the same shall in any way affect its obligations on this bond, and it does hereby waive notice of any such change, extension of time, alteration or addition to the terms of the Contract or to the work or to the other portions of the Contract Documents.

IN WITNESS WHEREOF the above-bounded parties have executed this instrument this ___ day of _____, 20__, the name and corporate seal of each corporate party being hereto affixed and these presents duly signed by its undersigned representatives, pursuant to authority of its governing body.

IT IS SO AGREED:

PRINCIPAL

SURETY

By: _____

By: _____

_____ [Name]

_____ [Name]

_____ [Title]

_____ [Title]

STATE OF CALIFORNIA

)

) ss.

CITY AND COUNTY OF _____

)

On _____, 20__ before me, _____, Notary Public, personally appeared _____, personally known to me (or proved to me on the basis of satisfactory evidence) to be the person(s) whose name(s) is/are subscribed to the within instrument and acknowledged to me that he/she/they executed the same in his/her/their authorized capacity(ies), and that by his/her/their signature(s) on the instrument the person(s), or the entity upon behalf of which the person(s) acted, executed the instrument.

Witness my hand and official seal.

Notary Public

STATE OF CALIFORNIA

)

) ss.

CITY AND COUNTY OF _____

)

On _____, 20__ before me, _____, Notary Public, personally appeared _____, personally known to me (or proved to me on the basis of satisfactory evidence) to be the person(s) whose name(s) is/are subscribed to the within instrument and acknowledged to me that he/she/they executed the same in his/her/their authorized capacity(ies), and that by his/her/their signature(s) on the instrument the person(s), or the entity upon behalf of which the person(s) acted, executed the instrument.

Witness my hand and official seal.

Notary Public

TO BE CONSIDERED COMPLETE, BOTH THE BIDDER AND AN ADMITTED SURETY INSURER AUTHORIZED BY THE CALIFORNIA INSURANCE COMMISSIONER TO TRANSACT SURETY BUSINESS IN THE STATE OF CALIFORNIA MUST SIGN THIS PERFORMANCE BOND. IN ADDITION, BOTH THE PRINCIPAL'S AND THE SURETY'S SIGNATURES MUST BE NOTARIZED AND A COPY OF THE SURETY'S POWER OF ATTORNEY MUST BE ATTACHED.